

TIPS • TOOLS • TECHNIQUES

ShopNotes[™]

\$4.95

Issue 5

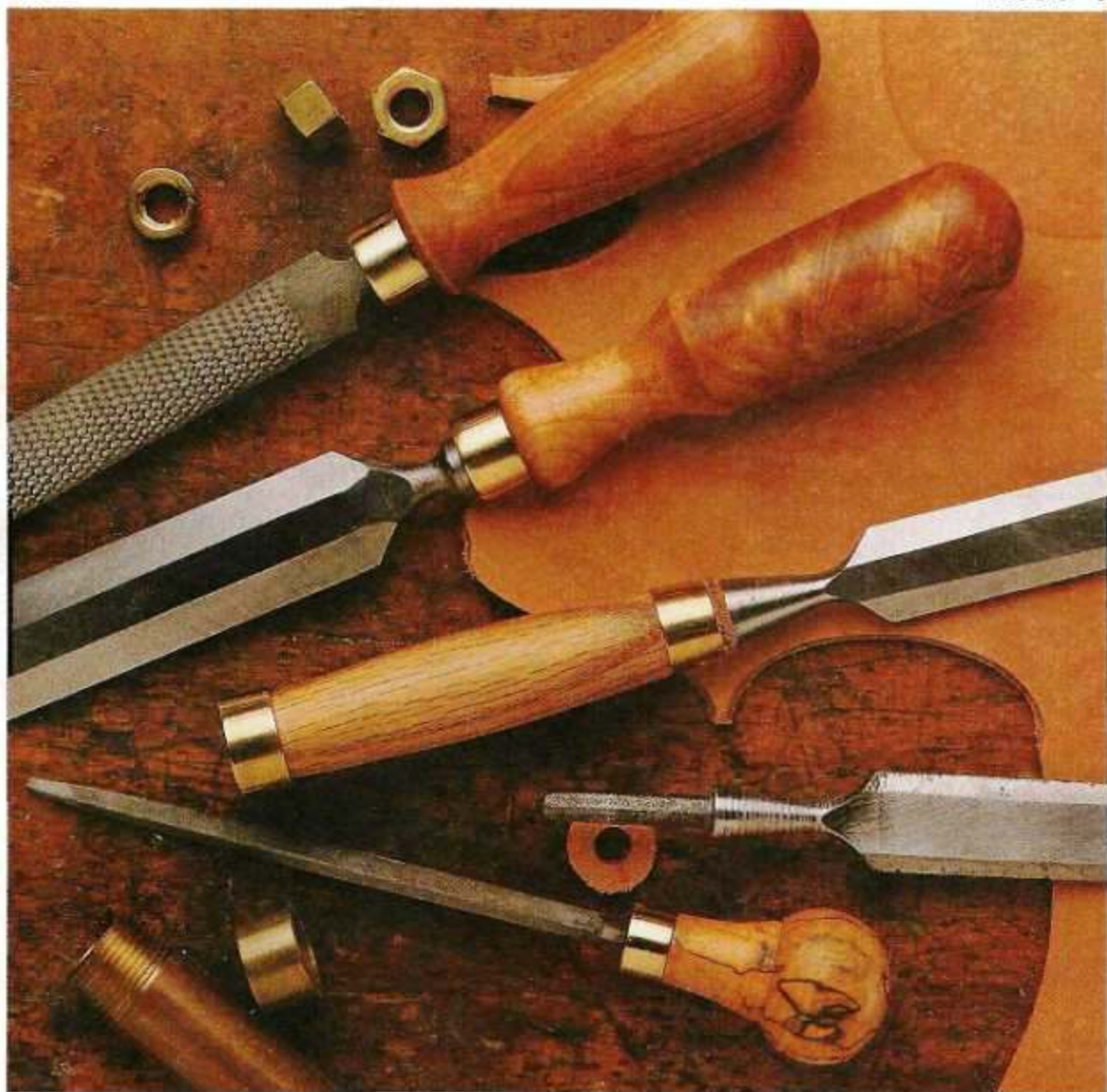

- Turned Tool Handles
- Small-Piece Miter Box

- Roll-Around Shop Cart
- Adjustable Set-Up Gauge



ShopNotes

Issue 5 September 1992

EDITOR Donald B. Peschke
EDITORIAL DIRECTOR Douglas L. Hicks
MANAGING EDITOR Terry J. Strohmman
ASSISTANT EDITORS Richard S. Peters
 Tim Robertson
CREATIVE DIRECTOR Ted Kralicek
ART DIRECTOR Cary Christensen
ILLUSTRATORS Kurt Schultz
 Will Niskanen
 Roger Reiland
 Mark Higdon
DESIGN DIRECTOR Ken Munkel
DESIGNERS Jan Halo Svec
 Kent Welsh
PHOTOGRAPHER Crayola England
SHOP MANAGER Steve Curtis

CIRCULATION DIRECTOR Liz Bredeson
SUBSCRIPTION MANAGER Phyllis Jessen
CIRCULATION ANALYST Jim Woodson
NEWSSTAND SALES Kent A. Buckton

CONTROLLER Paul E. Gray
ACCOUNTING Linda O'Rourke
BOOKKEEPING Julianne Spears
NETWORK ADMIN. Douglas M. Lidster
ADMINISTRATIVE ASSTS. Cheryl Scott
 Julia Fish
RECEPTIONIST Jeanne Johnson
BUILDING MAINTENANCE Ken Griffith

MARKETING DIRECTOR Robert Murry
PROJ. SUPPLIES ART DIR. Cindy Jackson
CUSTOMER SERVICE MGR. Laura McNelly
PROJECT SUPPLIES Leslie Ann Gearhart
 Linda Jones
TECHNICAL SUPPORT Jonathan Garbison
SYSTEMS OPERATOR Linda Morrow
RECEPTIONIST Keri Lee

CUSTOMER SERVICE
 Jennie Enos (Supr.), Jeff Janes, Joy
 Johnson, Sara Johnson, Ami Blanshan
SHIPPING DEPARTMENT
 Jerry Carson (Supr.), Gloria Sheehan,
 Ronald Long, Don McVey, Chuck Carlson

ShopNotes (ISSN 1042-0096) is published bimonthly (January, March, May, July, September, November) by Woodsmith Corporation, 2200 Grand Ave., Des Moines, IA 50312. Printed in U.S.A.

ShopNotes is a trademark of Woodsmith Corporation. ©Copyright 1992 by Woodsmith Corporation. All rights reserved.

Subscriptions: Single Copy, \$4.95. One year subscription (6 issues), \$19.95. Two years (12 issues), \$35.95. Canada/Foreign, add \$4.00 per year.

Second Class Postage Paid at Des Moines, IA and at additional offices.

Postmaster: Send change of address to ShopNotes, Box 11204, Des Moines, IA 50340-1204

Subscription Questions? Call 1-800-333-6854, 8am to 5pm, Central Time, weekdays.

EDITOR'S NOTE

Hardwood, softwood, plywood, pegboard, and Masonite. Just a few of the materials we used to make the projects in this issue. Often we take the material we use for granted. But selecting and using the right material is the basis for quality in a project.

NEW FEATURE. In this issue, we're introducing a new feature called Lumberyard. Over time we'll look at the standards used for lumber. How it's graded. New products and materials. And tips on selecting the best product.

This feature is a result of all the questions we receive about wood.

This time we're taking a look at some of the grading standards for hardwood lumber.

To get a better understanding of these standards we sent Rick Peters to a National Hardwood Lumber Association Seminar.

Rick came back from the seminar muttering about a sore back and lots of work. (Actually, I think he had a great time hanging around the saw mill.)

But in the end, it was worth it. Rick gathered a mountain of information and some new insights on lumber standards.

CATALOG. Another change you may notice is there's not a Shop Supplies catalog with your issue. This is not an oversight. The Shop Supplies catalog is being completely redesigned.

The people involved with the catalog are looking at new ideas and products. And new ways of presenting these ideas to you.

In the mean time we will continue to offer kits and hard to find hardware on the Sources page.

HARDWARE. Speaking of hardware, starting with this issue we are including a hardware list with each project.

Whenever possible, the projects in *ShopNotes* are designed to use hardware that is readily available. Or can be easily substituted for something similar.

But, occasionally a hard to find piece of hardware works better than anything else. In this case it's the magnet we used for the Set-Up Gauge.

It's called a *rare earth magnet* and is much stronger than any of the other magnets we tried. The only problem is this type of magnet is not readily available, so we're offering these magnets on the Sources page.

BRASS. I've always admired the look of brass and wood tools. Two of the projects in this issue (Tool Handles and the Set-up Gauge) have brass parts.

But brass parts are used for more than decoration. For example on the tool handles shown on page 10, I used a brass ferrule. The ferrule is installed on the end of the handle and prevents it from splitting.

For the Set-Up Gauge shown on page 24, I used brass for different reasons. To protect the base of the gauge from wear, I added a wide brass strip. Another brass strip keeps the 6" metal rule vertically aligned.

ADDITIONS. Since the last issue of *ShopNotes* we've added a few new faces. Mark Higdon is helping produce the art work. Kent Welsh has joined our design staff. And Jeanne Johnson is our new receptionist.

Contents

Small-Piece Miter Box _____ 4

Cut tight-fitting miters on small pieces of trim with this shop-made miter box.



Small-Piece Miter Box page 4

Small Shop Tips _____ 8

Five space-saving tips to make your woodworking shop more comfortable and efficient.

Tool Handles _____ 10

Manufactured handles are designed so "one size fits all." A custom-turned handle looks and feels better.



Tool Handles page 10

Turning Jig _____ 14

You don't have to own a lathe to turn wood. This simple jig lets you turn small projects on your drill press.

Roll-Around Shop Cart _____ 16

Pegboard panels and pull-out trays combine to create much-needed storage space. Adding casters converts the cart into a mobile work surface.



Shop Cart page 16

Stub Tenon & Groove _____ 22

The secret to this strong and simple joint is to glue a man-made panel into the grooves of a frame.

Adjustable Set-Up Gauge _____ 24

This shop-built precision gauge ensures accurate height, depth, and distance measurements.

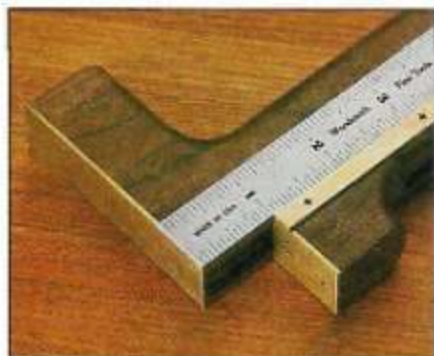

Set-Up Gauge page 24

Shop Solutions _____ 28

Five shop-tested tips: Drilling Tip, Scroll Saw Blade Organizer, A Tip for Turning, Squaring a Miter Gauge, and Pads for C-clamps.

Lumber Thickness _____ 30

Find out why saw mills, lumber yards, and retail outlets often use different terms to designate lumber thickness.

Sources _____ 31

Hardware, project supplies, and mail order sources for the projects in this issue.

Small-Piece Miter Box

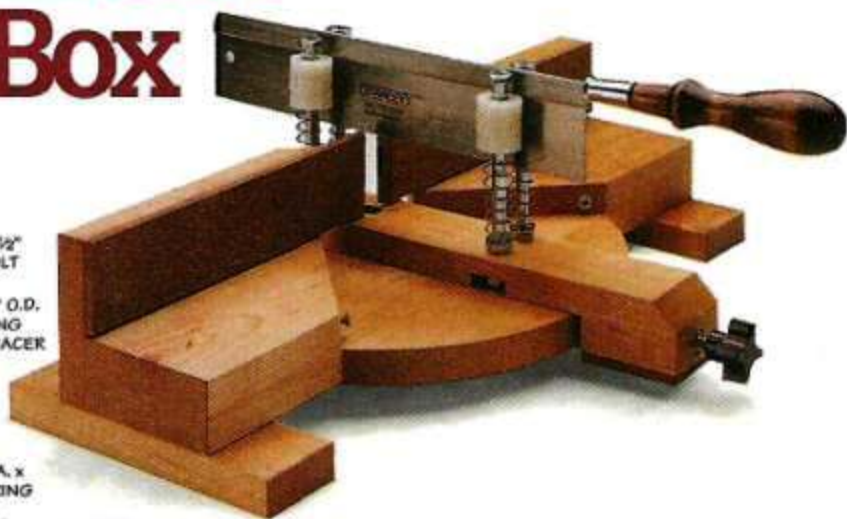

Hardware

- (8) 1½" Fh Screws
- (10) 1¼" Fh Screws
- (2) 5/16" Hex Nuts
- (4) 5/16" Washers
- (4) 5/16" x 4½" Hex Head Bolts
- (1) 5/16" Thrd. Insert
- (1) 5/16" x 1" Thrd. Knob
- (1) ¼" x 2" Hex Bolt
- (2) ¼" Washers
- (1) ¼" Lock Nut
- (12) 3/8" Nylon Spacers, 3/8" I.D. x 1" O.D.
- (4) 9/16" x 2½" Compression Springs

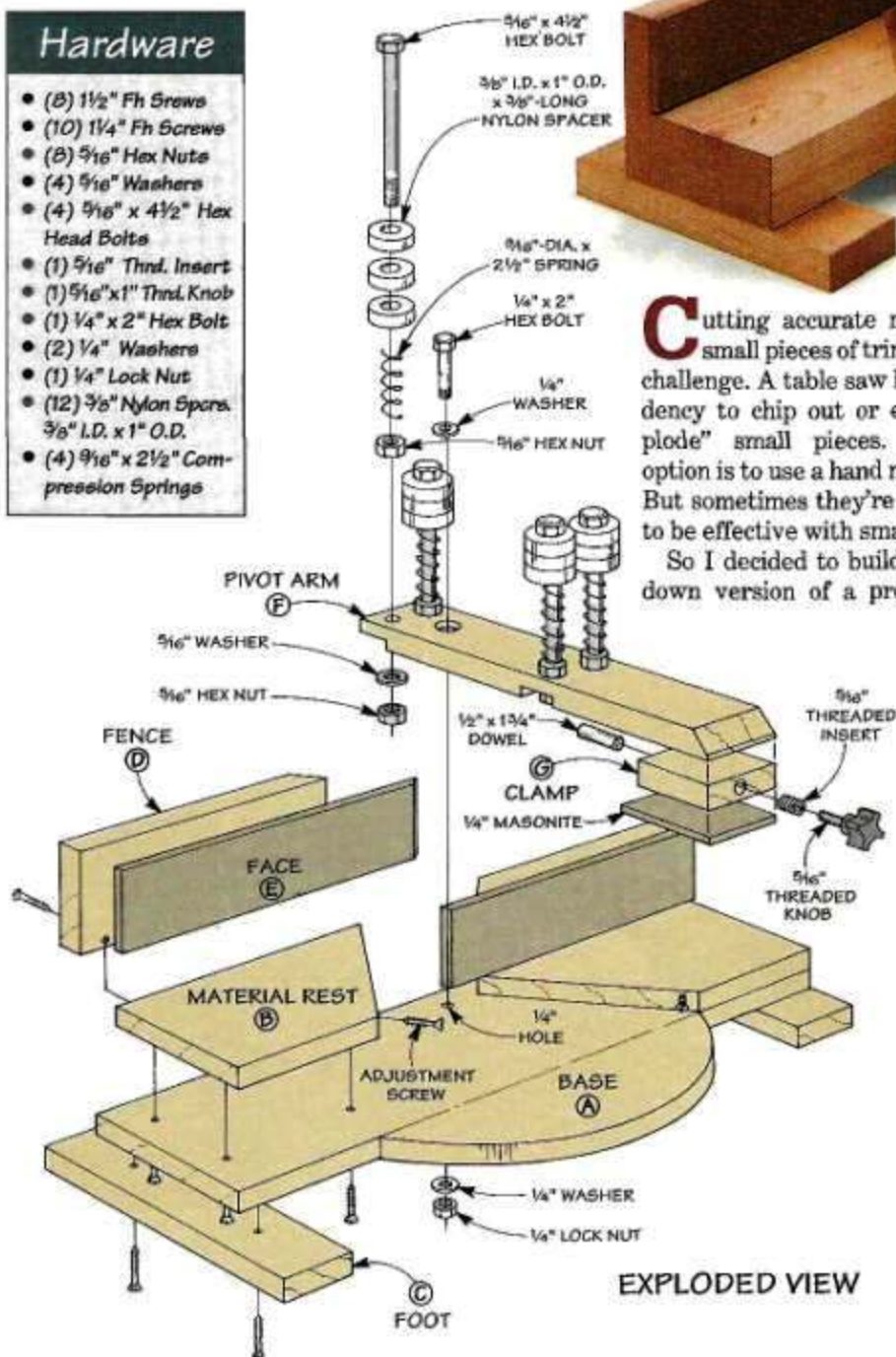

Cutting accurate miters on small pieces of trim can be a challenge. A table saw has a tendency to chip out or even “explode” small pieces. Another option is to use a hand miter box. But sometimes they’re too large to be effective with small pieces.

So I decided to build a scaled down version of a professional

miter box. It uses a 10”-long back saw and is designed with all the features of a full-size miter box.

FEATURES. The miter box is designed so the saw can adjust to angles up to 45° in each direction. And there’s a “stop” that lets you “fine tune” the 45° cuts. Finally, there’s a unique guide system that keeps the saw cutting straight.

THREE PARTS. The miter box has three main parts: a base assembly, a fence, and a pivot arm, see Exploded View. (I used ¾”-thick maple for all wood parts.)

BASE ASSEMBLY

To make the miter box, the first step is to build the base assembly. It consists of a base, a material rest, and a pair of feet.

BASE. The *base* (A) is made up of two pieces, see Fig. 1. To allow clearance for the pivot arm to swing, the front edge is curved. An easy way to make this curve is to dry-clamp the pieces and then draw a 6” radius, see Fig. 1.

Then simply remove the clamp, cut the curve on the front piece, and glue the base together.

PIVOT HOLE. To complete the base, drill a ¼”-dia. hole at the center of the radius. This is used later to attach the pivot arm to the base.

MATERIAL REST: The next step is to make the *material rest (B)*. The purpose of the rest is to raise a workpiece off the base. This creates a space that allows the pivot arm to swing back and forth.

The material rest is made of two pieces — each with a 45° miter on one end, see Fig. 2. Holes are drilled in the mitered ends for adjustment screws. These screws act as “stops” for the pivot arm and are used to fine tune the 45° angles of the saw.

ATTACH REST: After the material rest is cut, the next step is to attach it to the base. Note: To create a lip for the fence to rest on, the back edge of the rest is located 3/4" in from the back edge of the base.

The trick is to position the two pieces so the back edges are in line with each other, see Fig. 2. This ensures that the fence (which is screwed to the material rest later) will also be straight. I checked the alignment with a straightedge, and then glued and screwed the rest (B) to the base.

FEET: To complete the base assembly, screw a *foot (C)* to each end of the base, see Fig. 3.

FENCE

The *fence (D)* provides a straight, even surface to hold a workpiece against. Like the material rest, it's made of two pieces, see Fig. 4.

Each of the pieces is mitered on one end to provide clearance for the pivot arm to swing. Then the

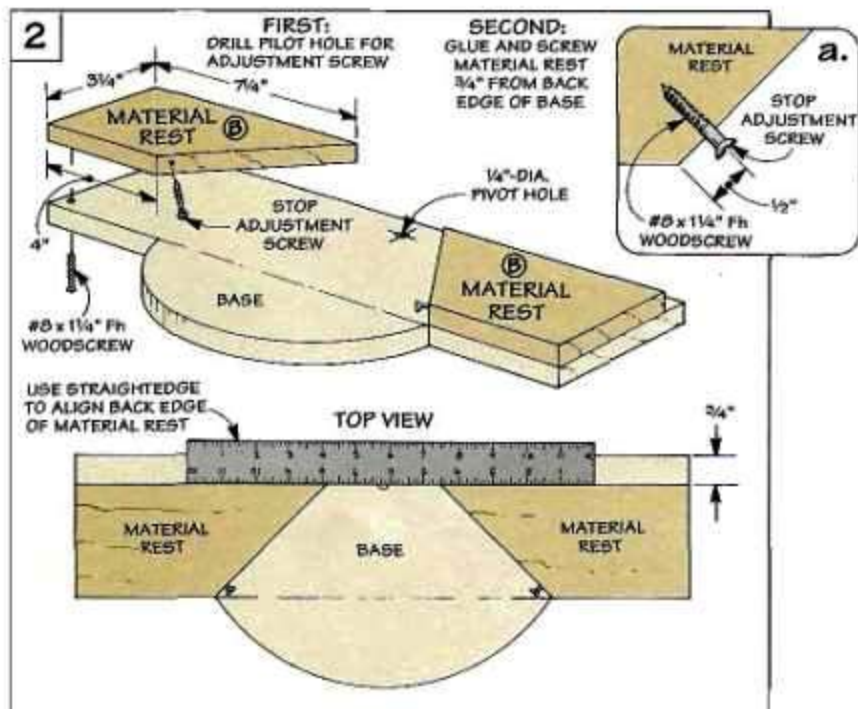
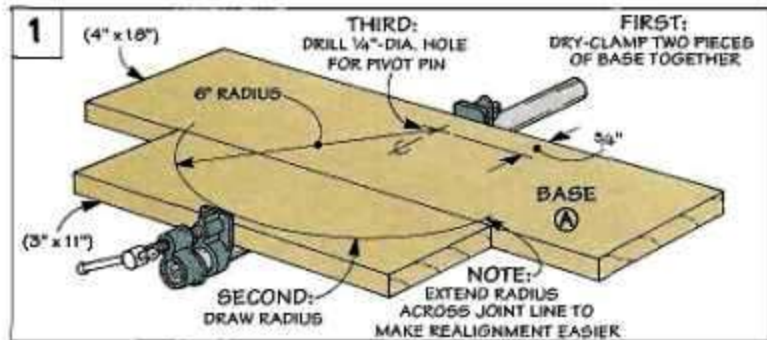

fence is screwed to the back edge of the material rest, see Fig. 4a.

FACE: After installing the fence, I added a *face (E)* made of 1/4"-thick Masonite. Here again, the

ends are mitered for clearance. Then the face is glued to the fence. To provide dust relief, I left an 1/8" gap between the material rest and the face, see Fig. 4a.

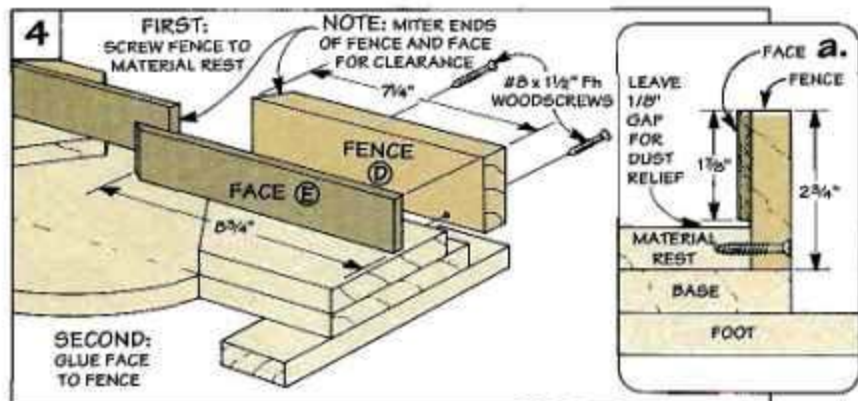
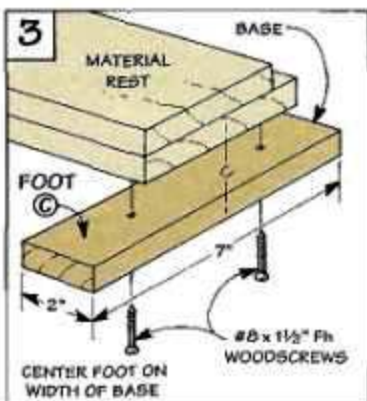

Pivot Arm

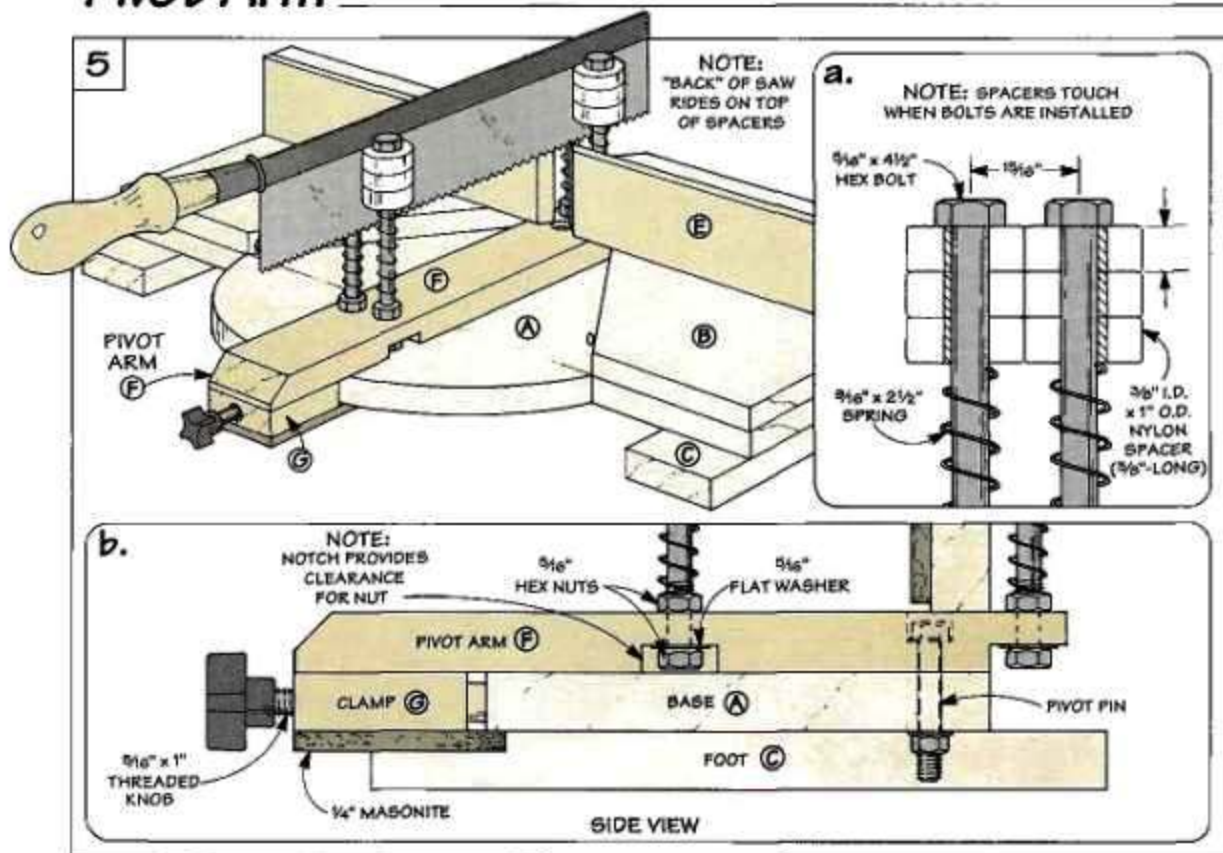

The heart of the miter box is the pivot arm. This arm does a couple of things. First of all, it serves as a platform for the system that guides the saw, see Fig. 5. And it pivots to position the saw at the desired angle.

The pivot arm starts out as a simple 2" x 10" blank, see Fig. 6. Then notches are cut on the bottom of the blank to provide clearance for the nuts that secure the guide system to the arm, see Figs. 5b and 6.

To attach the arm to the base, counterbore a pivot hole near the notched end. The other end of the arm is chamfered to relieve the sharp corner.

GUIDE SYSTEM

After cutting the arm to shape, the next step is to install the guide system. This system supports the saw and "tracks" the blade in a straight line.

NYLON SPACERS. The key to the guide system is a dozen nylon spacers I picked up at the hardware store, see Fig. 5. (There's also a source of hardware for the miter box on page 31.) Three of these spacers and a spring slip loosely over each of four hex bolts. Then

these "guide bolts" are mounted in pairs on the pivot arm.

When you slide the saw between the bolts, the spacers press against the side of the blade and eliminate any "play".

DRILL HOLES. To make this all work, it's important to locate the

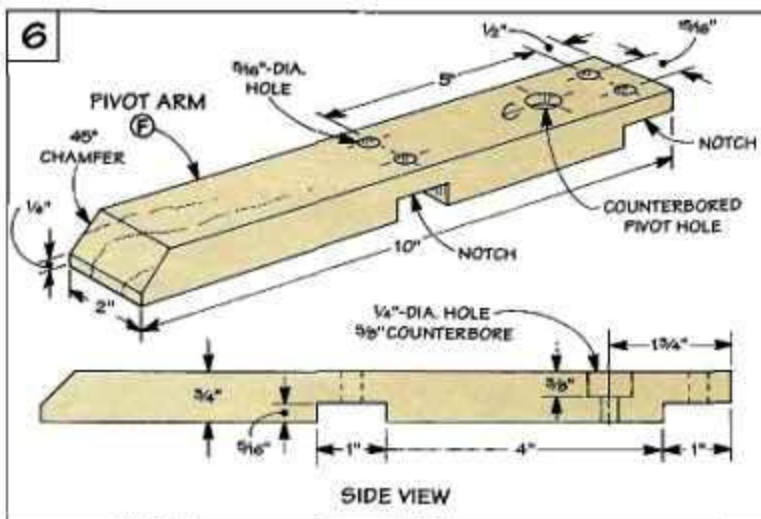

holes for each pair of bolts so the spacers touch, see Fig. 5a. (I drilled the holes so the center-points are $15/16$ " apart, see Fig. 6.)

Why doesn't this side pressure cause the blade to bind? Because of the holes in the spacers. They're *larger* than the diameter of the bolts. So with each stroke of the saw, the spacers spin easily.

In addition to guiding the blade, the spacers support the metal "back" of the saw, see Fig. 5. When you make a cut, the spacers travel down the bolts *with* the blade. When the cut is finished, the springs return the spacers (and saw) to the starting position.

CLAMP

After installing the hardware for the guide system, I made a *clamp* (G) to lock the arm in place, see Fig. 7. The clamp is just a wood block with a hole drilled through it to house a threaded insert and dowel, see Fig. 7a.

Tightening a knob (or thumb-screw) in the insert pushes the end of the dowel against the curved edge of the base. This locks the arm in place. Note:

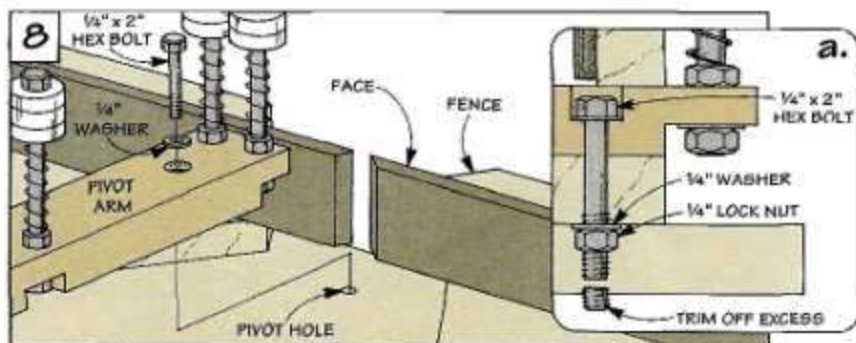
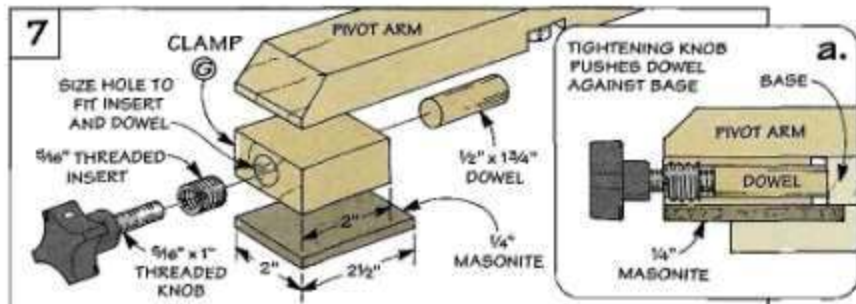

You'll need to sand the dowel so it slides easily in the hole.

Next, to prevent the arm from lifting when the knob is tightened down, I glued a piece of $1/4$ " Masonite to the bottom of the clamp.

ATTACH ARM. All that's left to complete the miter box is to attach the arm to the base, see Fig.

8. To do this, I used a 2" hex bolt as a pivot pin. (This is longer than I needed, but the smooth shaft prevents the threads from "chewing up" the pivot hole.)

Finally, after tightening a lock nut snug on the end of the bolt, the excess threads can be cut off, see Fig. 8a.

Adjusting the Miter Box

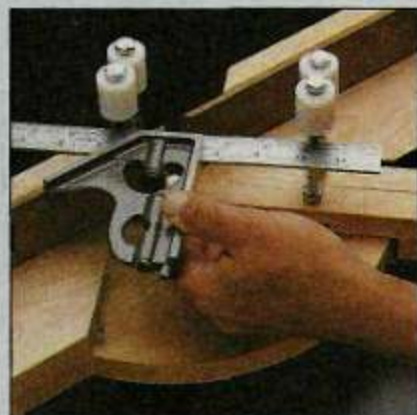

Step 1: Place the 45° face of a combination square against fence. Then pivot the arm so guide bolts touch the edge of the blade and lock arm in place.



Step 2: Next, cut a test piece to check the accuracy. To fine tune the 45° angle, move the adjustment screw in or out until the angle is perfect.

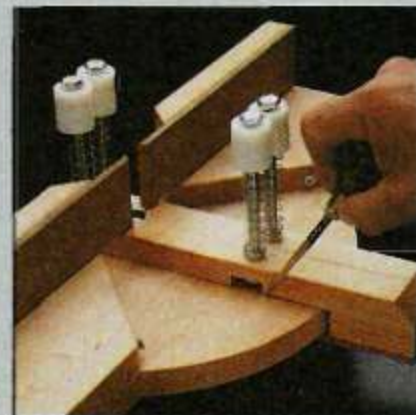

Step 3: To position the pivot arm for 90° cuts, repeat the process of rough positioning the arm and making trial cuts. Then scribe a line on the base.

Small Shop Tips

These five space-saving tips will help you get the most out of your small workshop.



COMBINING TOOLS

One space-saving tip is to combine two stationary tools into one. An example of this would be to turn the extension wing of your table saw into a router table, see drawing.

Besides saving floor space, there's another advantage to this set-up. You can use your rip fence to guide a workpiece on both the table saw and the router.

Note: When you're not using the router, just lower the bit so it doesn't protrude through the top of the extension.

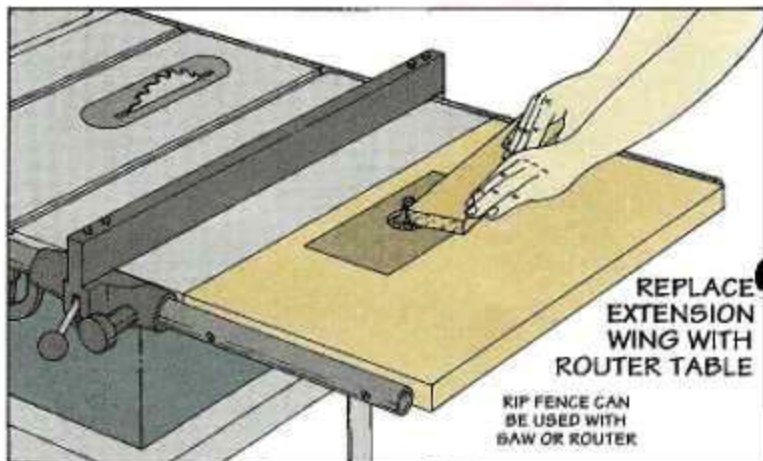

SHARING BENCH SPACE

There never seems to be enough bench-top space in the shop. A simple turntable can help you get the most out of the space available, see drawing.

Mounting tools to a turntable keeps them grouped tightly together, but still accessible. This lets you turn wasted space (such as a corner of a bench) into a handy work station.

The turntable is just a plywood disk that's bolted through its center to a bench. To reduce friction, furniture glides are nailed to the bottom of the plywood. To "lock" the turntable in position, drill holes through the turntable into the bench top and insert a dowel.

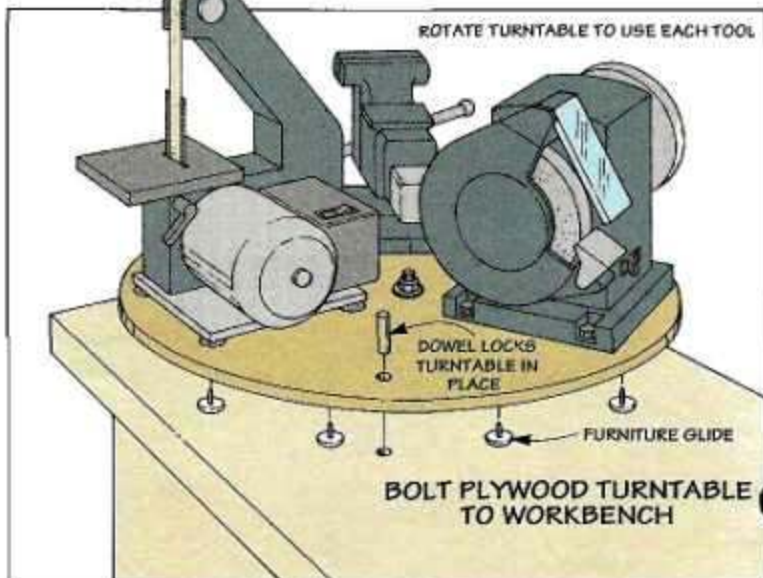

EXTRA WORK SPACE

If space is limited in your shop, you can convert your table saw into a light-duty assembly or finishing area.

This is easy to do. Just slip a shop-made cover over the top of the saw, see drawing.

The cover is a piece of plywood that's cut to fit the overall dimensions of your saw table. To keep it from shifting in use, glue wood trim around the edges.

Note: This cover is not designed for heavy weights or hammer blows.

CUT PLYWOOD COVER TO FIT YOUR SAW

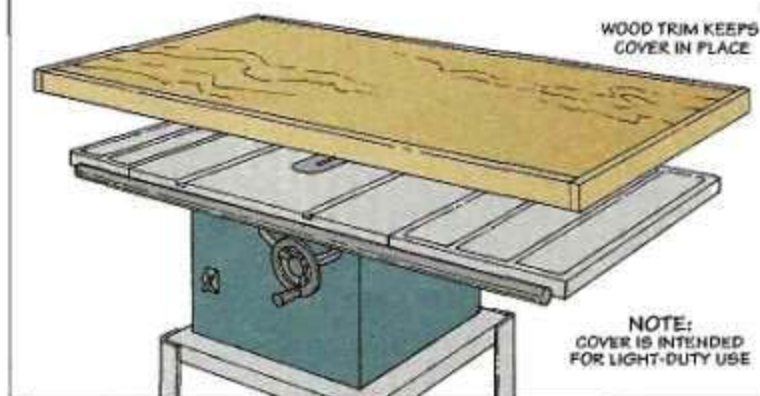

SUPPORTING WORK

It's surprising how well two tools can work together if you position them next to each other.

For example, locate a drill press next to a radial arm saw, see drawing.

Positioning the drill press like this allows you to support and safely cut long boards on the radial arm saw.

To do this, position the drill press to the *left* of your radial arm saw. Then raise or lower the drill press table until the workpiece lays flat on the saw table. When it's level, make the cut.

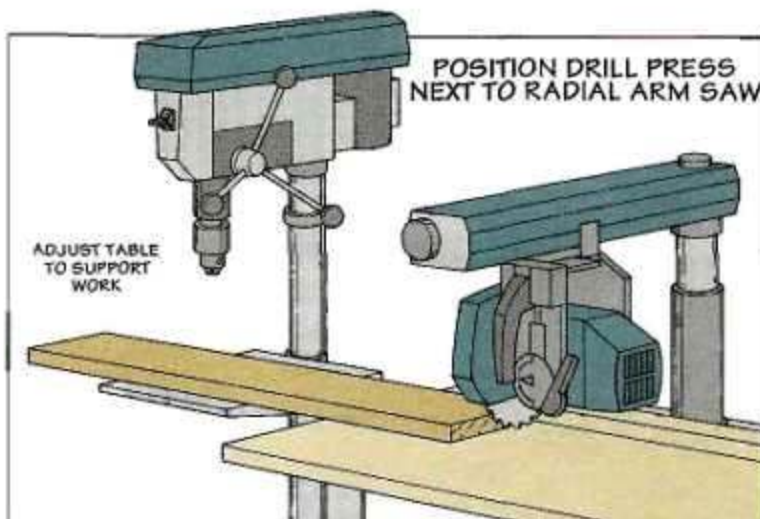

TOOL GROUPS

Many woodworkers position their tools around the perimeter of the shop. But grouping tools together can save a lot of space, see drawing. The trick is positioning the tools so they don't interfere with each other in use.

For example, if your router table is the same height (or slightly lower) as your table saw, you can position it behind the saw. This way it saves space and acts as an outfeed table.

Or if the top of your jointer fence is lower than the top of your table saw, you can slide it right up next to the table saw.

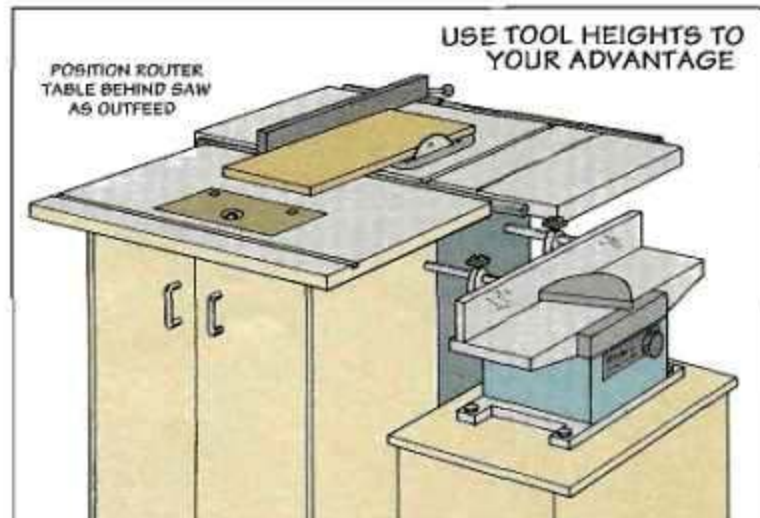

Tool Handles

You can make your own finely crafted tool handles designed to fit your hand like a glove.



If you have an old file laying around the shop, or a chisel with a broken handle (maybe one that belonged to your grandfather), you can make it into something special by adding a custom handle. There's nothing tricky about turning a tool handle. In fact, you don't even need a lathe or turning tools to make any of the handles shown on these pages. (For more on turning handles, see page 14.)

WOOD. One of the first things to consider for a handle is the material. A chisel handle that's going to be hit with a mallet requires a tough, springy wood like oak. While a handle for a file or a paring chisel is a good place to try out different kinds of hardwood.

FITTING. No matter what wood you use, the important thing is the fit of the handle on the tool. For tools with a tang (files and most chisels), you have to drill a hole in the end of the handle for the tang, see box below. Then the handle is driven down over the tang until it wedges tight.

It's not easy to drill a hole straight down the center of the handle, *after* it's turned. Instead, I drill a small pilot hole in the block *before* I start turning.

Once the handle is complete, I use the pilot hole as a guide to drill the hole for the tang. (For step-by-step instructions, see the box below.)

FERRULES. To prevent the tang from splitting the handle, a ferrule (metal collar) is mounted over the end of the handle.

I've tried making ferrules from small pieces of brass tubing. But the tubing stretches out of shape, and then rattles around or falls off. The ferrules shown on the handles here are made from brass hex nuts. (See page 13 for more on this.)

Drilling a Hole for the Tang

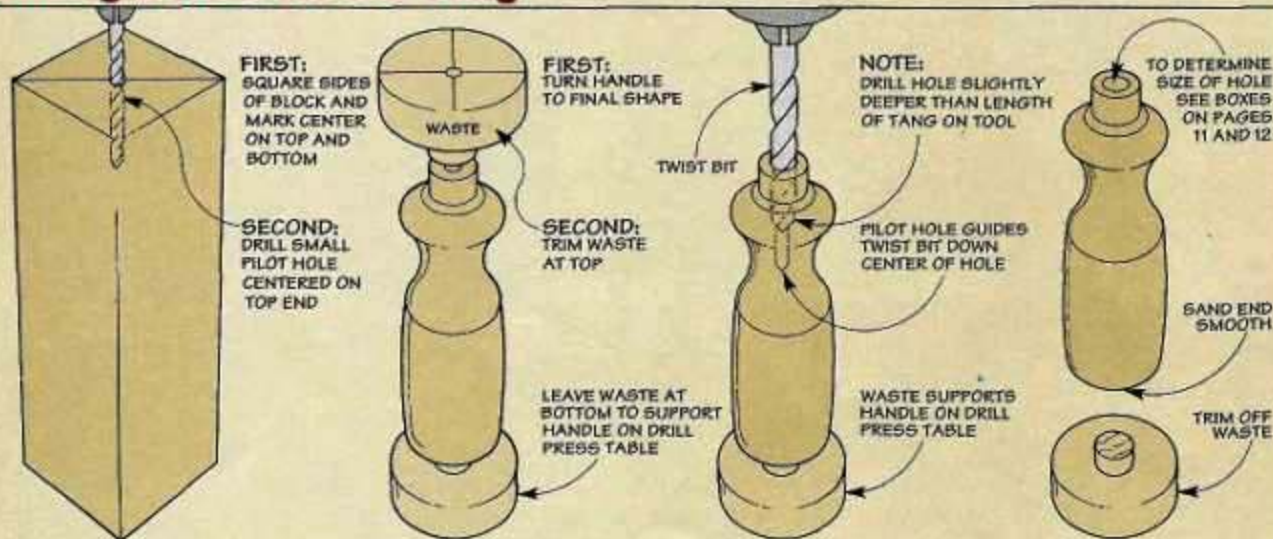

Step 1: Drill a pilot hole centered on the top end of the block. This is used to guide the bit when drilling the larger hole for the tang.

Step 2: Now turn the handle to shape and trim the waste off the top. The bottom is left on to provide support when drilling the hole.

Step 3: Using a twist bit to "follow" the pilot hole, drill a hole that's slightly deeper than the length of the tang on the tool.

Step 4: To complete the tool handle, trim off the waste at the bottom end of the handle. Then sand the end smooth.

File Handle

One of the ironies with top quality files and rasps is that they don't come with a handle. You're expected to make your own.

That's actually a blessing in disguise. The handles that come on cheaper files are usually too small for comfort and control.

A good handle on a file can make a big difference in the fatigue on your hand and the ease of applying pressure where you want it — especially on a project that requires a lot of shaping.

For large files and particularly wood rasps, I prefer a large handle like the one shown above.

MATERIALS. Making a file handle like this offers a good opportunity to experiment with different

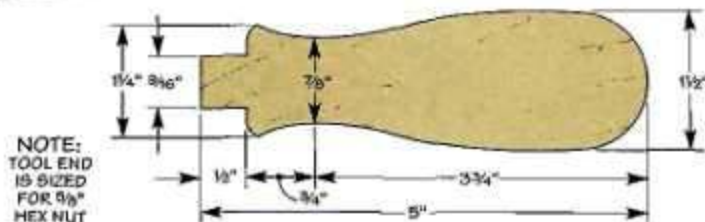

◀ A rounded end that tapers gently to a finger stop... that's the secret to the comfortable grip on this large file handle made of cherry.

kinds of wood. I used cherry because it's tight-grained, turns well, and the color contrasts nicely with the brass fittings.

HANDLE SHAPE. The handle is shaped with a large rounded end. Then it tapers to a neck, and increases again to create a stop for your thumb.

Basically, the length and thickness of the handle is a matter of individual preference. To fit my

hand comfortably, I turned the handle 5" long with the rounded end at a 1 1/2" diameter.

This is slightly larger than most manufactured handles because I have a tendency to squeeze small handles with a "white knuckle" grip.

FERRULE. To prevent the end from splitting, I turned it to accept a 5/8" brass nut as a ferrule. (For more on ferrules, see page 13.)

Palm Handle

Smaller files require a lighter touch — and a different handle. A palm handle (like the one shown at right) makes filing a lot easier and provides protection so the end of the file doesn't poke into your hand.

ROUND KNOB. The idea of the palm file handle is simple. A round knob about the size of a golf ball provides a cushion for the palm of your hand.

This type of handle is designed to work with your fingers extending over the tool itself. The round end really just serves as a "stop" against the palm of your hand.

I turned the knob to a diameter of 1 1/2". Try this size and then modify the size depending on the size of your hand.

TAPER. The neck of the handle is turned to a short taper — just long enough to rest your knuckle and extend your index finger past

the taper to guide the file. (The tapered neck on this handle is only 7/8" long.)

TOOL END. Like the large file handle, a hole is drilled in the end of the handle to accept the tang.

The tool end of the handle is turned to accept a brass nut that serves as a ferrule. Because of the smaller tangs on these files, I used a 1/2" brass nut. (For more on fitting the tang in the handle, see box at right and page 10.)

MATERIALS. As for the material for this handle, I used a piece of spalted maple to create a highly figured design.

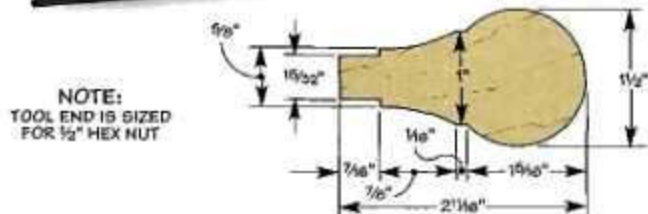

◀ A round palm handle to cushion your hand... and a small size for exact control.

Fitting a File

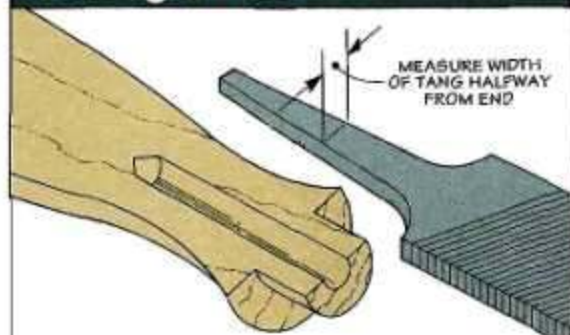

The hole for the file is sized to fit the width of the tang halfway from the end of the tool, and is slightly deeper than the length of the tang.

Traditional Handle



The handle for a paring chisel must have a barrel that fits the palm of your hand, and the neck should be shaped to fit your thumb.

NOTE:
TOOL END
IS SIZED
FOR 5/8"
HEX NUT

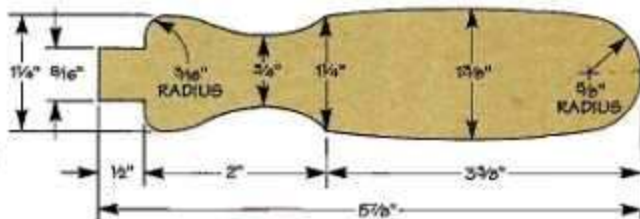

The form of a chisel handle is determined by its function. For a paring chisel (that is meant to be pushed rather than struck), I chose a rather traditional handle.

This style is especially suited for handwork because the barrel of the handle tapers to a small neck, which then flares to a thumb stop.

The barrel should be sized to fit your hand comfortably. And the

neck should be sized and shaped to fit your thumb so you feel comfortable pushing the blade into the wood without fear of slipping.

Compare this to the chisel handle below that is designed to be struck with a mallet.

DOMED END. Another feature of this handle is the rounded or "domed" end. When using two hands to push the chisel through a workpiece, the dome helps cush-

ion the heel of your hand.

Although it's not intended to be hit with a mallet, the domed end can withstand light pounding without splitting. (I would use a wood mallet with a leather face.)

FERRULE. The tool end of the handle is sized for a 5/8" brass hex nut that serves as a ferrule. (For more on this, refer to page 13.)

Like file handles, a hole is drilled in the tool end to accept the tang on a chisel, see box below.

MATERIALS. Since this handle is not intended to be struck with a mallet you can use just about any kind of wood. I turned a piece of maple which created a unique swirling pattern on the handle shown above.

Barrel Handle

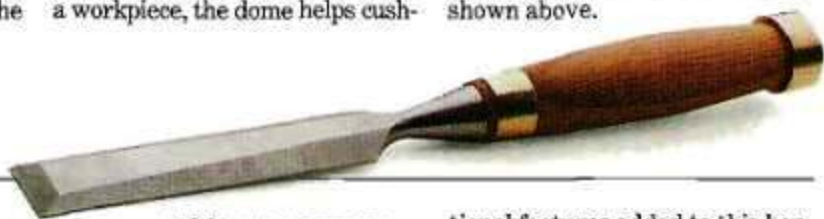

Straight-grained oak, a hoop, and a leather washer combine to help this handle withstand blows from a mallet.

NOTE:
TOOL END
IS SIZED
FOR 5/8"
HEX NUT

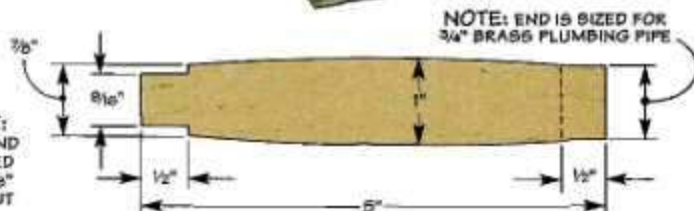

tional features added to this handle to help it withstand the shock from a mallet.

HOOP. First, I added a hoop on the end of the handle to protect it from splitting or deforming.

The hoop is made from a section of brass pipe. Since it doesn't screw on (like the brass nut I used for the ferrule), it's fitted to the end of the handle and sized so the wood mushrooms over the hoop to hold it in place. (For more on making a hoop, refer to page 13.)

LEATHER WASHER. At the other end of the handle, I used a 5/8" brass hex nut for a ferrule, as on the other handles.

But before attaching the handle, I added a leather washer to fit between the tool and the ferrule. The washer acts as a "shock absorber" to help cushion the blows of a mallet. (I made this washer from an old belt.)

Fitting a Chisel

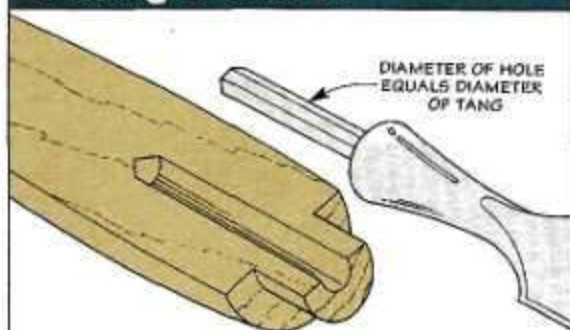

To fit the chisel in the handle, the hole is sized to match the diameter of the tang and drilled slightly deeper than the length of the tang.

If you're going to use a chisel primarily for chopping, the handle should be designed to withstand repeated blows.

WOOD. To take the shock from a mallet, the wood for the handle needs to be tough and springy. (I chose oak for the handle shown above.) Also, the wood should be straight-grained and free of knots to reduce the chance of breakage.

HANDLE SHAPE. The shape of the handle is not as critical as that of a paring chisel. I chose a simple barrel-shaped handle that's easy to grip with my hand.

However, there are two addi-



Ferrules

Turning the handle to shape is just the first step. To mount the chisel blade to it you need to drill a hole for the tang. Then you can drive the handle onto the blade.

TANG. However, the problem here is the tang acts as a wedge and can easily split the handle. To prevent this, a ferrule is mounted to surround the hole for the tang.

FERRULE. I made a ferrule by grinding the "corners" off a brass hex nut. (I chose brass because it's easy to grind to shape and polishes up nicely.)

◀ Ferrules made from brass hex nuts prevent the handle from splitting when driving it onto the tang.

Installing the ferrule is simple. Just tighten the nut in a vise and screw the handle into the nut like a wooden bolt, see Fig. 1.

FINISH. When the nut "bottoms out" on the handle, back it off and grind the corners smooth, see Fig. 2. To polish the ferrule, sand it with progressively finer grits (120 to 600) of silicon carbide sandpaper.

LEATHER WASHER. As an option, you may want to add a leather washer as a "shock absorber" between the blade and the ferrule, see Fig. 3.

SEAT HANDLE. After retightening the ferrule, the last step is to seat the chisel blade in the handle. To do this, place the cutting end of the blade against a wood block and drive the handle onto the tang, see Fig. 3.

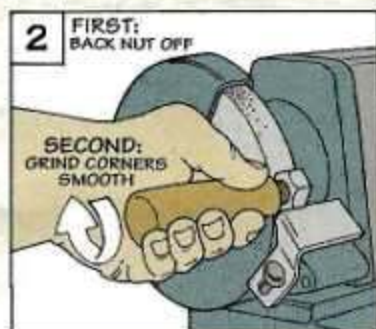
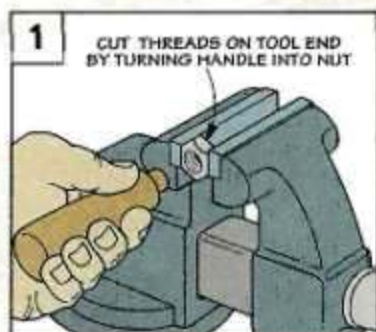

Hoops

It doesn't take much pounding on a handle before the end starts to split and deform. To prevent this, I install a metal hoop on the end of the handle, see Fig. 1.

BRASS PIPE. The hoop is cut from a short length of $\frac{3}{4}$ " brass pipe. (I picked the pipe up in the plumbing department at the hardware store.)

To prevent gouging the wood ◀ A metal hoop made from a piece of brass pipe reinforces the end of a chisel handle.

◀ A metal hoop made from a piece of brass pipe reinforces the end of a chisel handle.

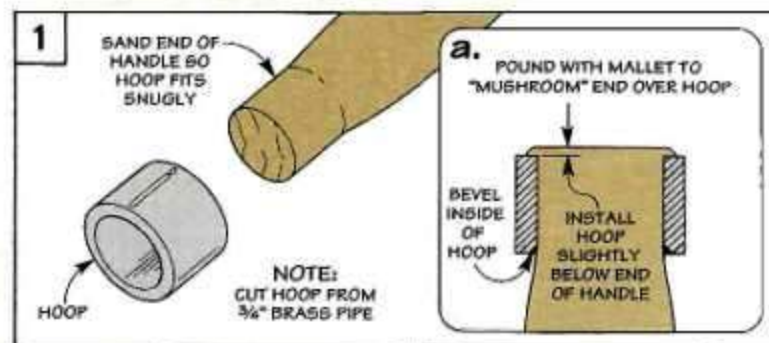

Unlike the ferrules, there are no threads to hold the hoop in place. So how do you keep the hoop from slipping off as the handle shrinks with changes in humidity?

The hoop is cut to length so it sits slightly below the end of the handle, see Fig. 1a. Then, after striking the handle a few times with a mallet, the exposed end grain bends over the hoop. This creates a "mushroom" that locks the hoop in place.

Turning Jig

All it takes to convert your drill press into a lathe are a few scraps of wood, a couple of bolts, and an ordinary screwdriver.

The guys in the shop were just a bit skeptical when I first showed them this turning jig. After all, using a drill press as a vertical lathe is a bit unorthodox, see photo. Not to mention the fact that I used an ordinary flat-bladed screwdriver as a turning tool. (For more on this, refer to box on page 15.)

After turning a few tool handles, everyone was amazed at how much this jig functioned like a standard lathe. That's because it has the same basic components as a lathe: a drive center, a tailstock, and a tool rest, see drawing below.

DRIVE CENTER. To turn a block of wood, you have to prepare one end of the block by cutting a diagonal kerf, and drilling a hole for the drive center, refer to Step 2 on next page.

The drive center transfers the rotation of the drill press chuck to the workpiece. It's made from a bolt with the head and threads cut off, and has a 6d nail mounted at one end of the bolt. (For a tip on drilling the hole to mount the nail, see page 28.)

TAILSTOCK. The other end of the workpiece spins on a tailstock. This is just a bolt or rod that fits in a block of $\frac{3}{4}$ "-thick hardwood.



Here again, the head and threads are cut off. To fit the center of the workpiece, grind one end to a point, see box below. Then drill a hole in the block to support and position the bolt on the drill press table.

TOOL REST ASSEMBLY. The last part of the turning jig is a tool rest assembly. The purpose of this assembly is to support and guide the scraper. It consists of three parts: a tool rest, a support block, and a base, see Exploded View. Note: The tool rest is made from hardwood, while the support block and base are made from plywood.

So that you can hold the scraper at an angle to the workpiece, cut a 45° chamfer on one edge of the tool rest, leaving a $\frac{3}{16}$ "-wide edge to support the flat side of the screwdriver blade.

To complete the turning jig, screw the tool rest and support block to one corner of the base.

EXPLODED VIEW

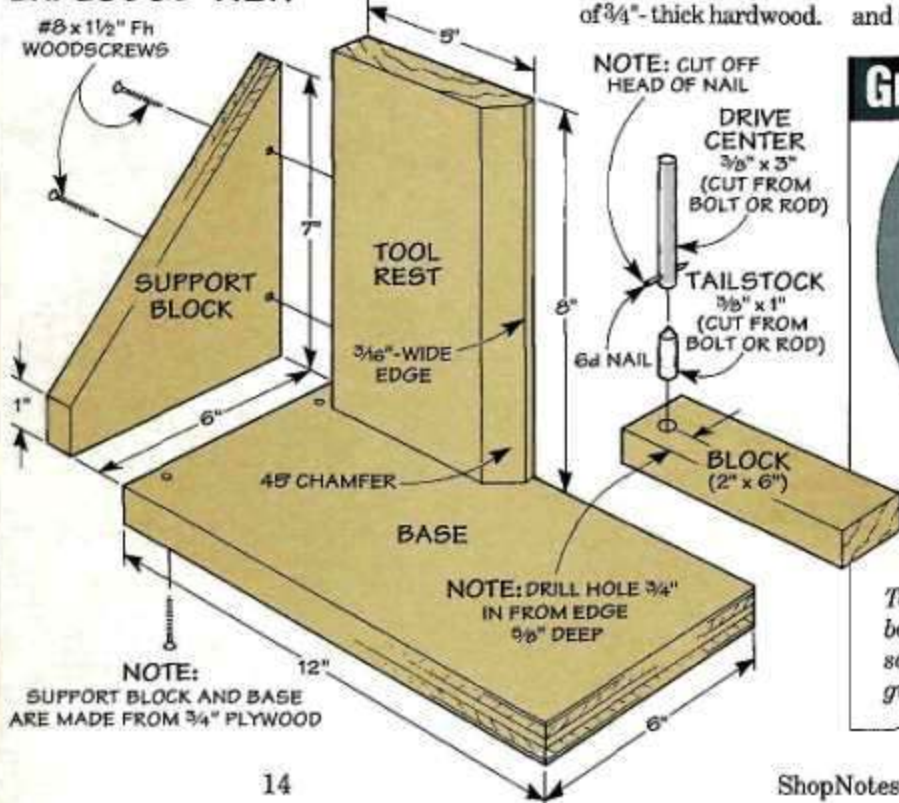

Grinding Tip

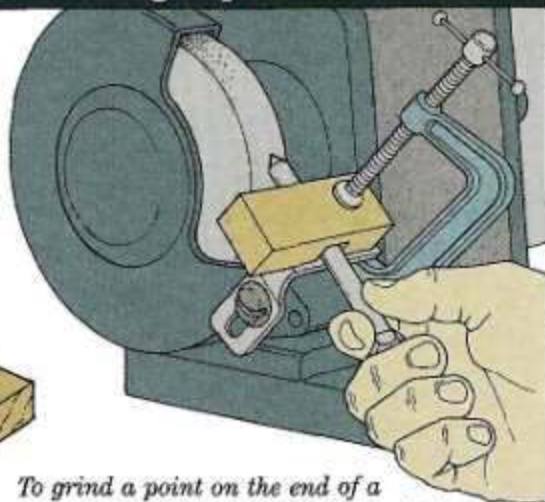

To grind a point on the end of a bolt or rod, clamp a block with a notch the same diameter as the bolt to the tool rest. Then grind the point as you rotate the bolt by hand.

Using the Turning Jig

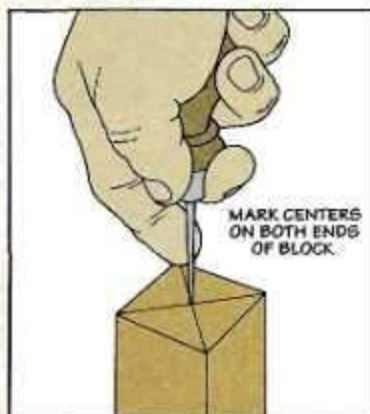

Step 1: To locate the top and bottom centers of the block, draw diagonals across the corners, and mark the centers with an awl.

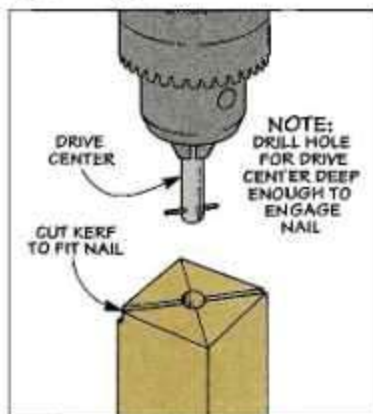

Step 2: Next, drill a hole to accept the end of the drive center. Then cut a kerf across one of the diagonal lines to engage the nail.

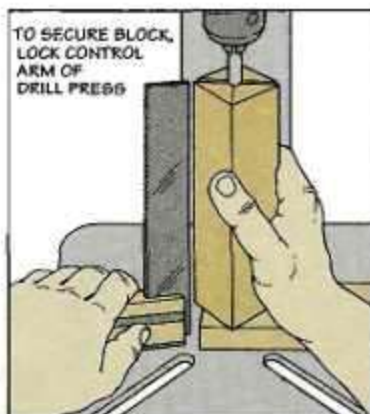

Step 3: After mounting the block between the drive center and the tailstock, square up the block and clamp tailstock to the table.

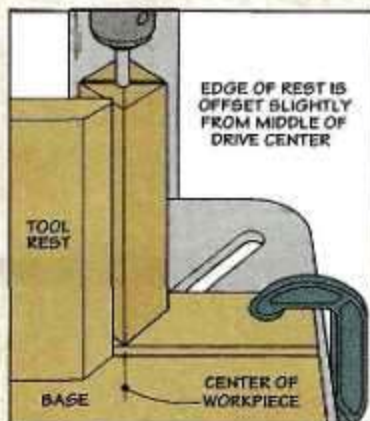

Step 4: Next, position the base on the drill press table so the edge of the tool rest is slightly to the left of the middle of the block.

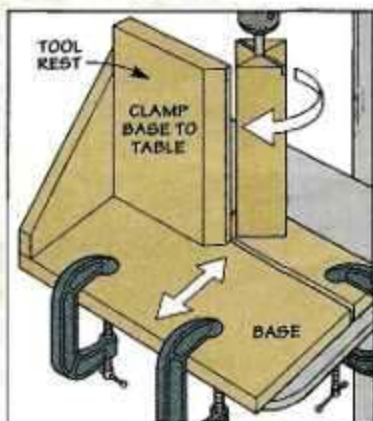

Step 5: Now clamp the base so edge of rest is $\frac{1}{8}$ " from the corners of the block. To check for clearance, rotate the block by hand.

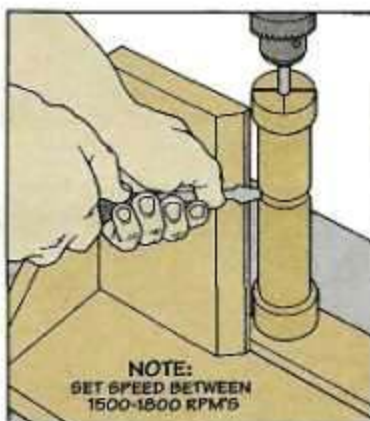

Step 6: Holding the flat part of the blade against the edge of the tool rest, gently push the cutting tip into the spinning workpiece.

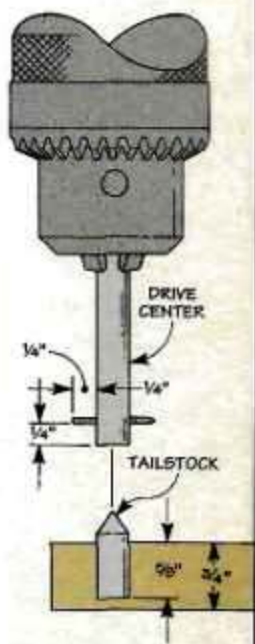

Like a lathe standing on end, the drill press chuck turns a block between two centers: a drive center and a tailstock.

Making a Scraper

All that's required to make a scraping tool is a screwdriver and a few minutes to grind a slight bevel on the end of the blade.

I made two different scrapers. On one, the corners are rounded to prevent the blade from "catching" when scraping a curve, see Fig. 1. The other has the original square corners for straight-shouldered cuts, see Fig. 2.

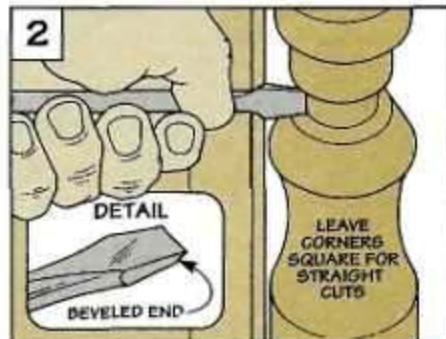
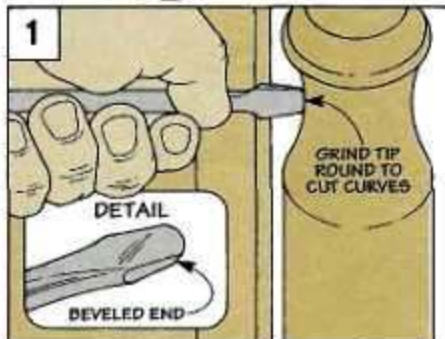



Roll-Around Shop Cart

Wheels, pegboard panels, and pull-out trays combine to make this roll-around cart a versatile addition to your shop.

Storage and bench space.

There never seems to be enough in the shop. Power tools and accessories end up buried under sawdust. And when a project gets started, the bench gets hidden under a pile of lumber.

What I needed was storage space that could double as a bench or work surface. And it had to be mobile. This way I could move it easily around the shop where it was needed. The solution to this problem is the shop cart shown above.

STORAGE SPACE. First of all, there's plenty of storage space, both inside *and* out. A divided sec-

tion *inside* the cart holds power tools and supplies. And an open area under the top is the perfect place to keep clamps handy.

PEGBOARD PANELS. Pegboard side and back panels provide an easy way to hang often used items on the *outside* of the cart. This keeps tools and other accessories right at hand.

OPTIONAL TRAYS. Trays on the inside of the cart *pull out* on full extension slides. And this makes it easy to find those tools and parts that always seem to hide way in the back.

JOINERY. Another feature of this cart is it's easy to build. I used a simple stub tenon and groove joint throughout. (For more on this joint, see page 22.)



▲ Pegboard panels are a convenient way to keep tools and accessories handy. And an open shelf under the top is the perfect place for storing clamps.

Cutting Diagram

3/4" x 5 1/2" - 72"



3/4" x 7" - 72" (TWO BOARDS)

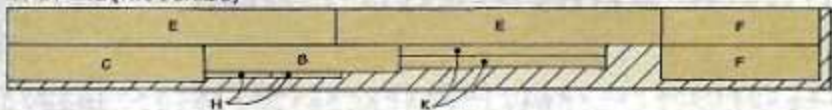

3/4" x 6 1/2" - 72" (TWO BOARDS)



3/4" x 6" - 72" (TWO BOARDS)

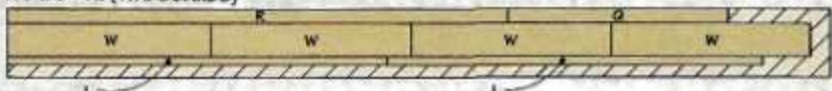

1" x 3 1/2" - 36"



ALSO NEED:
1/2" x 48" - 96" FIR PLYWOOD
1/4" x 48" - 48" MASONITE
1/4" x 48" - 48" PEGBOARD

EXPLODED VIEW

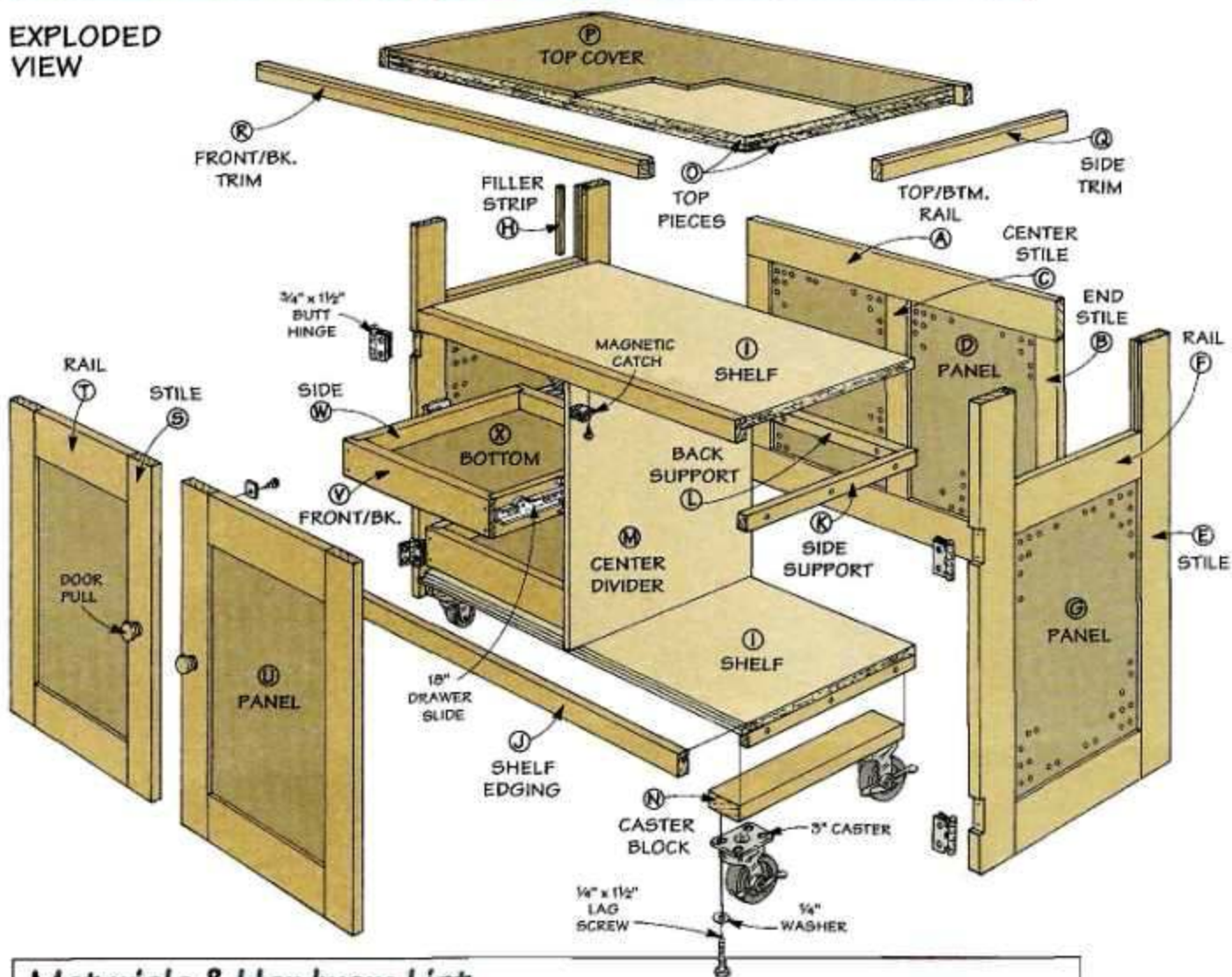

Materials & Hardware List

Back

A	Top/Btm. Rails (2)	3/4 x 3 - 34 1/2
B	End Stiles (2)	3/4 x 2 1/4 - 17
C	Center Stile (1)	3/4 x 3 - 17
D	Panels (2)	14 x 17 - 1/4 Pegboard

Sides

E	Stiles (4)	3/4 x 3 - 28 1/2
F	Rails (4)	3/4 x 3 - 14
G	Panels (2)	14 x 17 - 1/4 Pegboard
H	Filler Strips (4)	1/4 x 1/4 - 6

Shelves

I	Shelves (2)	18 1/4 x 34 1/2 - 1/2 ply
J	Shelf Edging (2)	3/4 x 1 1/2 - 34 1/2
K	Side Supports (4)	3/4 x 1 - 18
L	Back Supports (2)	3/4 x 1 - 33
M	Center Divider (1)	18 3/4 x 20 - 1/2 ply
N	Caster Blocks (2)	1 x 3 - 17 1/4

Top

O	Top Pieces (2)	19 1/2 x 42 - 1/2 ply
P	Top Cover (1)	19 1/2 x 42 - 1/4 Masonite
Q	Side Trim (2)	3/4 x 1 1/4 - 19 1/2
R	Front/Bk. Trim (2)	3/4 x 1 1/4 - 43 1/2

Doors

S	Stiles (4)	3/4 x 3 - 22
T	Rails (4)	3/4 x 3 - 12 1/2
U	Panels (2)	12 1/2 x 16 1/2 - 1/4 Masonite

Pull-Out Trays

V	Front/Backs (4)	3/4 x 2 3/4 - 16
W	Sides (4)	3/4 x 2 3/4 - 17 1/2
X	Bottoms (2)	15 1/4 x 17 1/2 - 1/4 Masonite

Hardware

- (4) 3" Casters w/Lag Screws
- (36) 1/4" Fh Woodscrews
- (2) 1 1/4" Door Pulls w/Screws
- (2) Pair 18" Drawer Slides
- (4) 3/4" x 1 1/2" Hinges w/Screws
- (2) Magnetic Door Catches

Back and Sides

The roll-around shop cart is basically a simple cabinet. It's made up of a back and two sides, refer to Exploded View.

BACK

I started work on the cart by making the back. The back is just a frame and two pegboard panels.

The frame consists of a *top* and *bottom rail* (A), two *end stiles* (B), and a *center stile* (C), see Fig. 1. The stiles fit between the rails and support the two pegboard panels (D).

JOINERY. After I cut the frame and panel pieces to size, I use a stub tenon and groove joint to join the frame and the panels together, see Details in Fig. 1. (For step-by-step instructions on how to cut this joint, see the article on page 22.)

SIDES

The sides are made just like the back. Except this time the rails fit between the stiles, see Fig. 2.

Each side is made up of two stiles (E), two rails (F), and a pegboard panel (G), see Fig. 2.

Note: To simplify construction of the cart, I used identical pegboard panels for both the back and the sides.

To create the open space under the top of the cart (for clamps and other tools), I positioned one of the rails (F) 6" down from the top of the stile (E), see Figs. 2 and 2a.

FILLER STRIPS. But there's a problem with positioning the rails like this. It leaves an open groove on the inside edge of each stile. To fill these grooves, I used *filler strips* (H), see Fig. 2a.

ASSEMBLY. After the filler strips are glued into the grooves, the last step is to assemble the basic cabinet.

To do this, glue and clamp the back between the sides so the bottom edges are flush, see Figs. 3 and 3a.

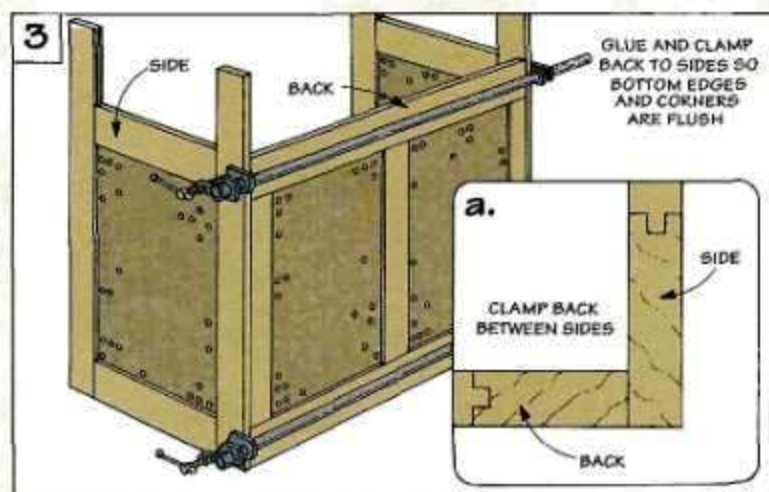
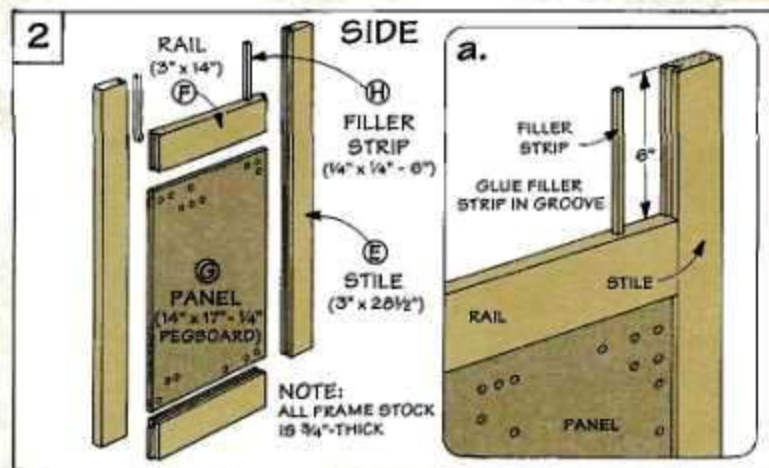
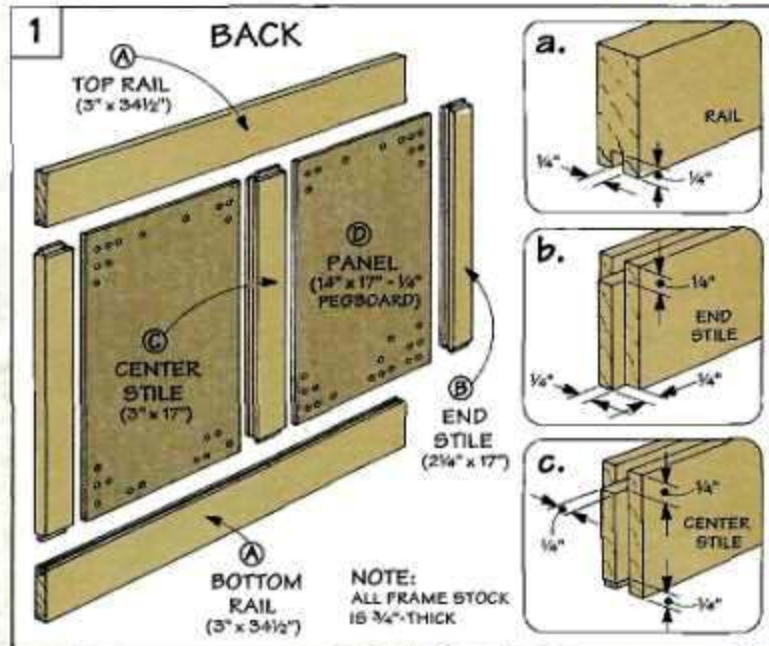

Shelves and Divider

The shelves of the shop cart provide storage space and help strengthen the cabinet. To prevent the shelf from bowing and to cover the plywood edge, I added a piece of shelf edging (J), see Fig. 4.

SHELVES. Each shelf (I) is made from a piece of 1/2" plywood. Then to prevent the shelf from bowing and to cover the plywood edge, I added a piece of shelf edging (J), see Fig. 4.

This edging is joined to the shelf with an offset tongue and groove joint, see Fig. 4a. After the joints are cut, the edging is glued to the shelf.

SUPPORTS. To attach the shelves to the cabinet, I used shelf supports. They're pre-drilled to make it easy to screw the shelves to the cabinet, see Fig. 4.

The side supports (K) are glued to the shelf first. Then a back support (L) is cut to fit between them, see Fig. 4.

ATTACH SHELVES. To attach the shelves, screw the lower shelf inside the cabinet so the bottom of the edging (J) is flush with the bottom of the cabinet, see Fig. 5.

Then to create a lip around the upper shelf (so tools won't roll off), position the shelf 1/2" below the top rails (A and F) and screw it in place, see Fig. 5a.

CENTER DIVIDER. Next, a center divider (M) is screwed between the shelves, see Fig. 6. The center divider is just a piece of 1/2" plywood with the top two corners notched to fit around the

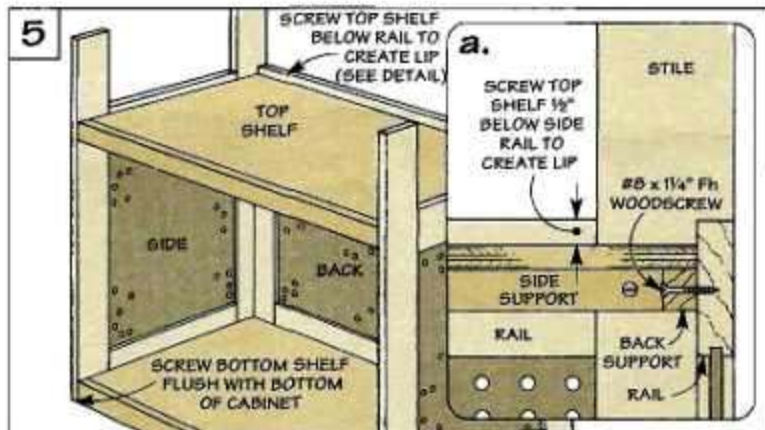
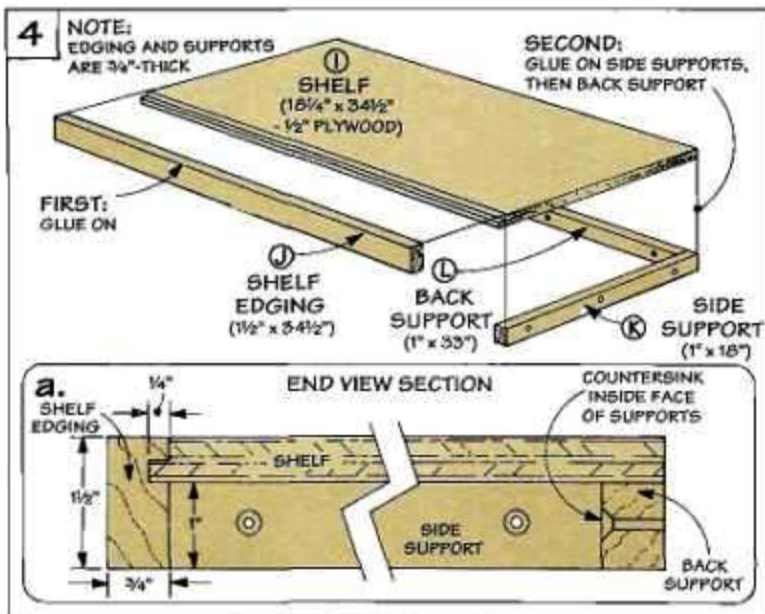

shelf edging (J) and back support (L), see Fig. 6a.

CASTERS. Finally, a set of caster blocks (N) are glued under the bottom shelf, see Fig. 7.

These 1"-thick blocks provide extra holding power for the screws that hold the locking swivel casters in place, see Fig. 7. (For sources of casters, see page 31.)

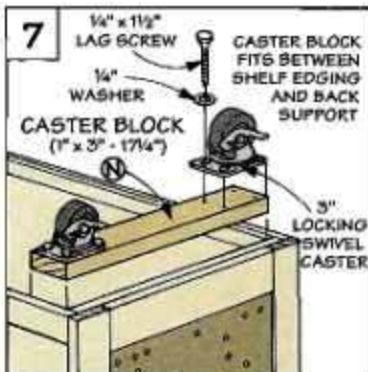
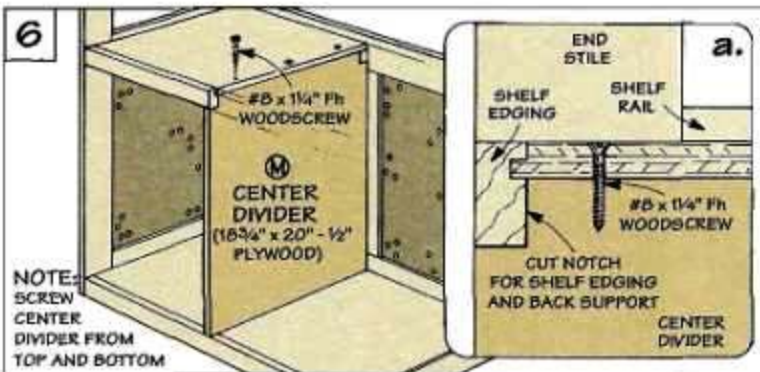

Top

With the center divider screwed in place, the next step is to make the top of the shop cart.

TWO PIECES. The top is made by gluing up two plywood *top pieces* (O). These pieces are cut to match the overall width of the sides (19½") and to a length of 42". Note: The 42" length allows for a 3" overhang on each end.

To "lock" the top in place, I cut dados on the underside of the plywood to fit over the side stiles (E), see Fig. 8a. Once they're cut, the top pieces are screwed to the cart, see Fig. 9.

TOP COVER. Since I wanted a hard, smooth surface for the top of the cart, I glued a Masonite *top cover* (P) on top of the plywood pieces (O), see Fig. 9.

Note: You can cut the top cover the same size as the top pieces (O), or cut it oversize and use a flush trim bit, see margin tip.

TRIM. The edges of the top are covered with *side trim* (Q) and *front/back trim* (R), see Fig. 9.

Before I glued the front and back trim (R) to the top, I knocked off the sharp corners by cutting a chamfer on the ends, see Fig. 9a.

After all of the trim is glued in place, I routed a ¼" chamfer along the top edge, see Fig. 9b.

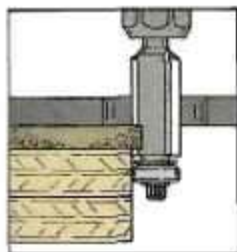

A flush trim bit in a hand-held router makes it easy to get a flush edge.

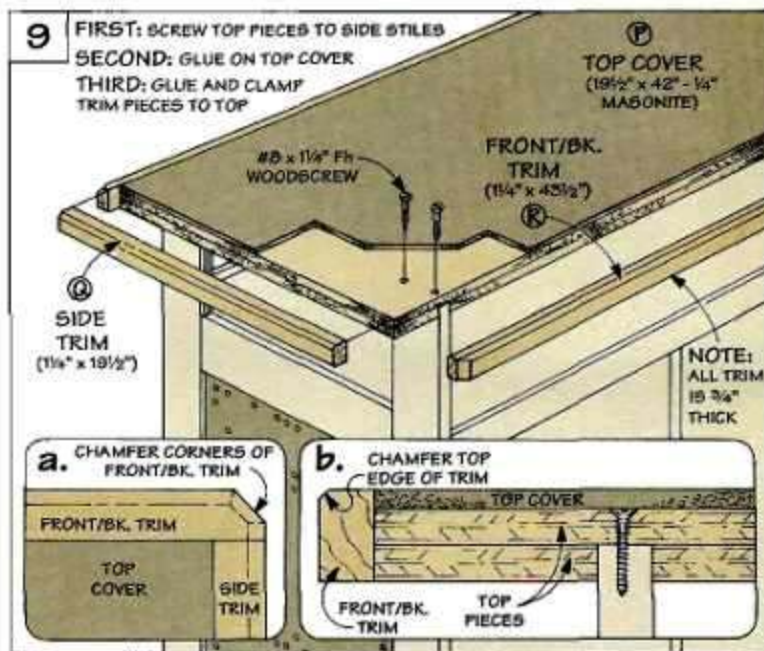
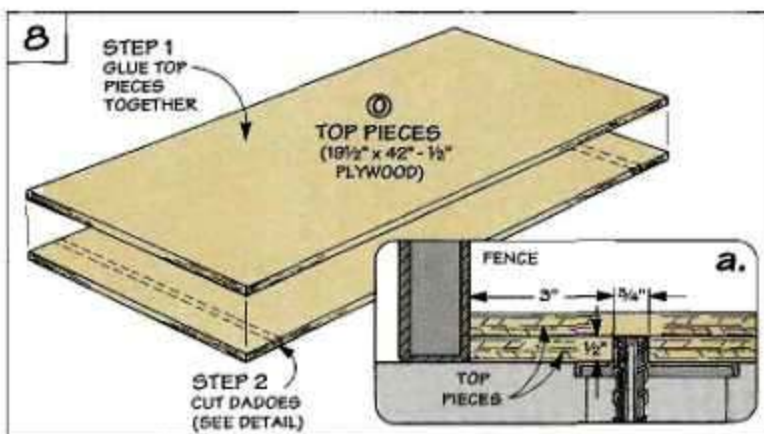

Doors

To reduce dust inside the cart, I added a pair of doors. The doors are made just like the rest of the cabinet — a simple frame and panel, see Fig. 10.

FRAMES. To make the frames, first cut the *stiles* (S) to match the distance between the bottom of the lower shelf and the top of the upper shelf (22" long), refer to Exploded View.

The *rails* (T) are a little trickier. The idea here is to cut them to length so the doors are tight

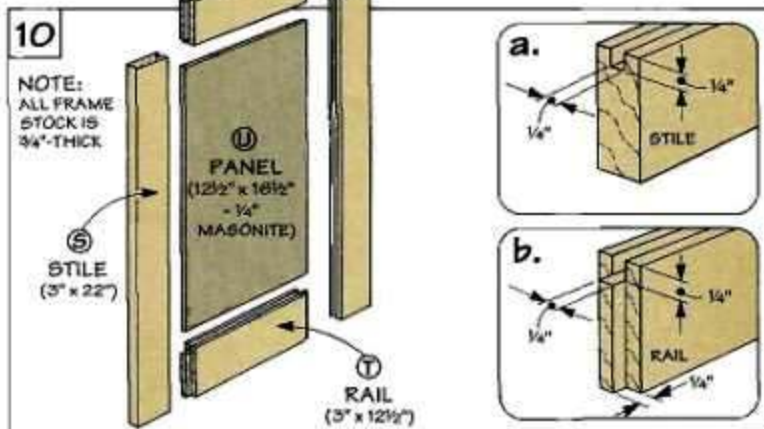

against each other and flush with the sides of the cabinet, see photo on page 16.

To do this you'll have to consider the width of the stiles (3"), and the length of the stub tenons (1/4"). In my case, the rails (T) measure 12 1/2" long.

PANELS. Since I wouldn't be hanging anything on the doors, the panels (U) are cut from solid Masonite. Here again, they're cut to fit the frames, see Fig. 10.

After the doors are glued up, you'll need to plane the stiles to create a 1/16" gap between the doors.

MOUNT DOORS. The next step is to mount the doors to the cabinet with butt hinges, see Fig. 11. The easiest way to do this is to cut mortises in the front edge of the side stiles (E) to match the thickness of the hinge, see Fig. 11a.

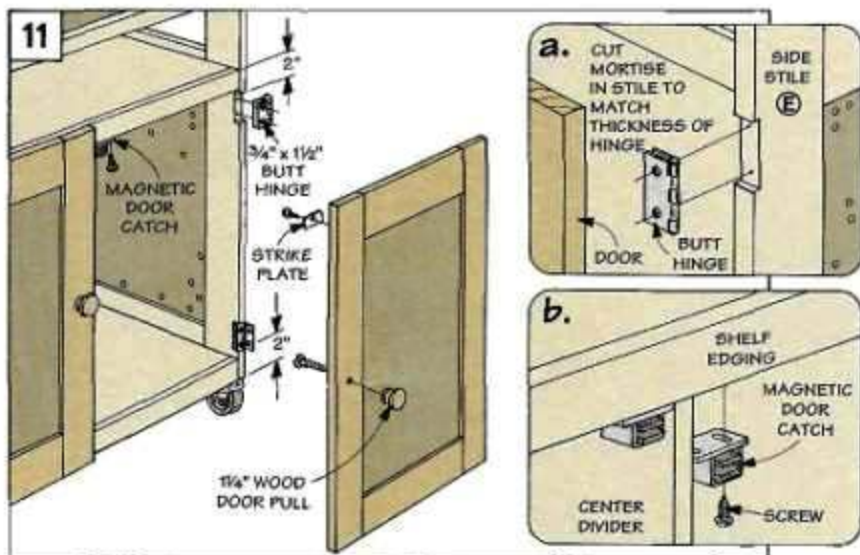

HARDWARE. After the doors are screwed to the cart, I installed a pair of magnetic catches, see Fig. 11b. They keep the doors closed when the cart is moved.

Next, I drilled centered holes in the door stiles and screwed on a pair of door pulls, see Fig. 11.

To complete the cart, brush on two coats of satin polyurethane.

Optional Pull-Out Trays

After completing the shop cart, I added a couple of pull-out trays. These trays slide all the way out on a set of full-extension drawer slides, see photo.

TRAYS. Each tray consists of a front/back (V) and a pair of sides (W). Note: Since the drawer slides require 1/2" of clearance on each side, the overall width of the trays is 16".

The ends of the tray are then joined together with an easy to

make rabbet joint, see Fig. 1.

Next, a groove is cut in the frame pieces to accept a Masonite bottom (X).

DRAWER SLIDES. The pull-out trays are mounted on a set of full-extension slides. (For sources of drawer slides, see page 31.)

The lower tray is mounted so it sits about 1/16" above the bottom shelf. And the upper tray is mounted 9 1/2" up from the bottom shelf, see Fig. 2.

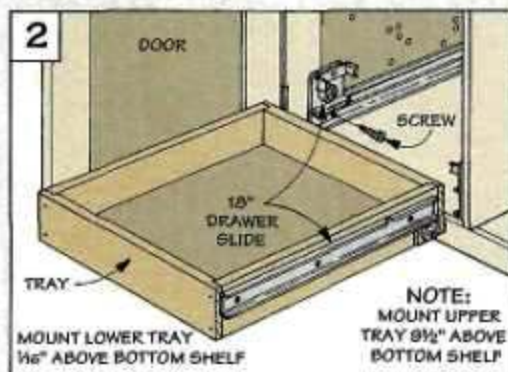
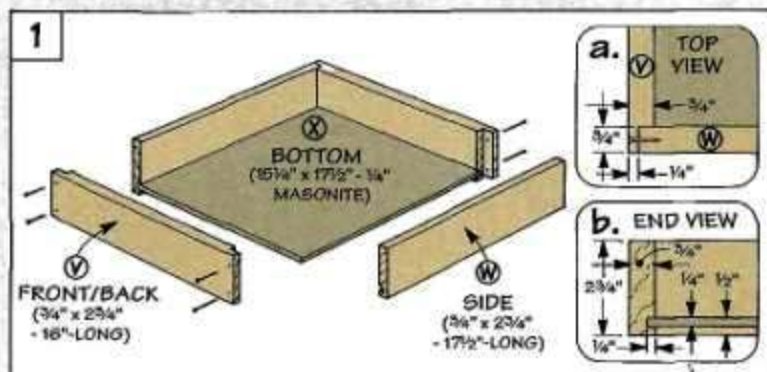

Stub Tenon & Groove

Simple joinery and a man-made panel create a strong frame and panel assembly.

Strength and simplicity. Two reasons why I often use stub tenon and groove joinery when a project calls for frame and panel construction.

Actually, this type of joint should only be used with one type of panel — a *manufactured* panel (such as plywood, Masonite, or pegboard).

These panels are dimensionally stable (they won't "move" with changes in humidity). This allows you to glue the frame directly on the edge of the panel, see Fig. 1.

Note: Solid wood panels should *never* be glued inside a frame. They must be able to "move."

With a stub tenon and groove joint, the frame pieces surround

the panel like "edging" and actually become part of the joint. This allows you to cut a short (stub) tenon that fits in the same groove as the panel instead of cutting a deeper mortise and a full-length tenon.

I use a two-step process to make a stub tenon and groove joint.

THE GROOVES. The first step is to cut grooves in the inside edges of *all* the frame pieces, see Figs. 1 and 1a. The grooves are sized to hold the panel in place with a friction fit.

Cutting the grooves (and later cutting the stub tenons) goes a lot easier if the grooves are centered on the thickness of the stock. Fortunately, this is easy to do. All it



takes is a simple set-up and a couple passes on the table saw. (Refer to Figs. 2 and 3.)

STUB TENONS. The next step is to cut short stub tenons on the ends of the rails to fit the grooves, refer to Fig. 1b. Just like the grooves, the tenons are cut in several passes.

The secret to getting a good fit is to cut the tenons slightly oversize. Then "sneak up" on the final thickness until the tenon just slips into the groove with a friction fit.

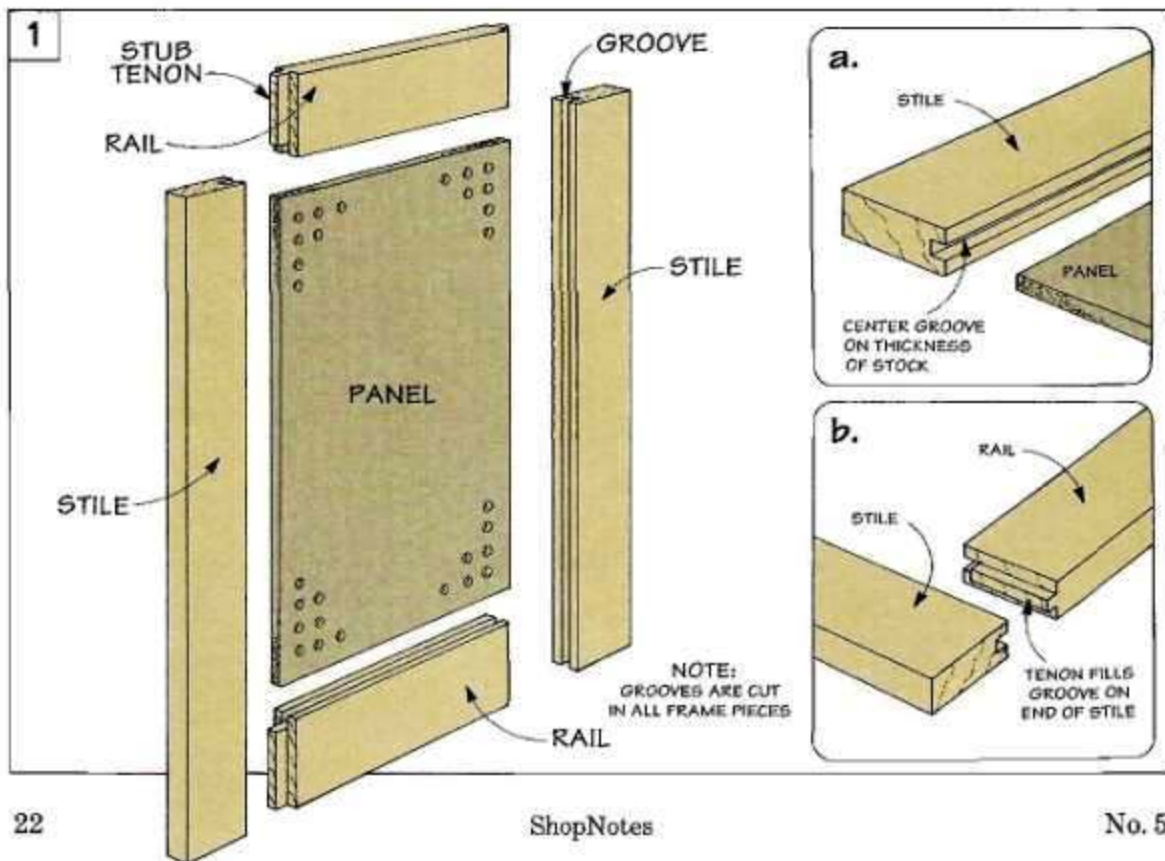

Cutting the Grooves

The grooves are cut in the rails and stiles for two purposes. First, they hold the panels in the frame. And second, they serve as open "mortises" for the stub tenons.

CENTERED GROOVE. The important thing is to cut a groove so it's centered on the edge of the frame piece. To do this, start by setting the blade height to the desired depth for the groove.

The trick to getting the groove perfectly centered is to start with the blade roughly centered on the workpiece, and make a pass, see Fig. 2.

Then without moving the rip fence, flip the piece end for end and take another pass, see Fig. 3.

TEST THE FIT. Now check the fit on the panel. If the groove isn't wide enough for the panel, move the fence and repeat the process. When you get a snug fit, cut a groove in all your frame pieces.

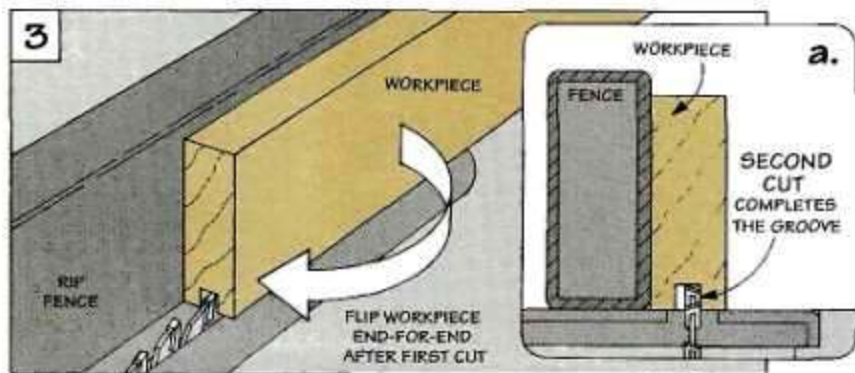
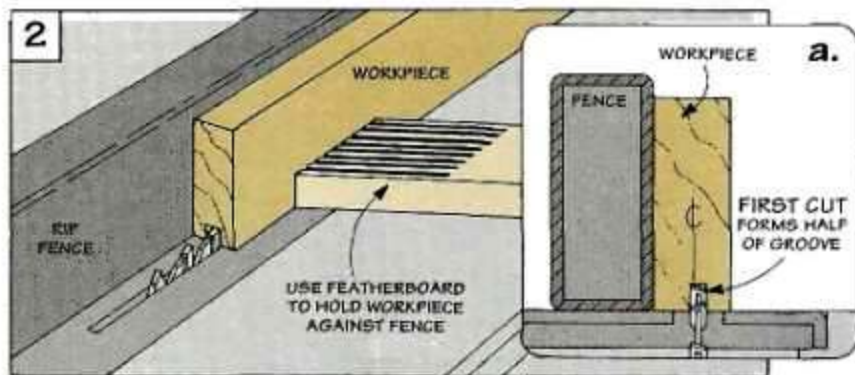

Cutting the Stub Tenons

After the grooves are cut, the next step is to cut stub tenons to fit the grooves. To do this, I use the same type of procedure as above, flipping the piece, and "sneaking up" on the final cut.

SET UP SAW. Start by setting the height of the blade by using one of the grooved pieces as a gauge, see Fig. 4.

Next, set the rip fence so the distance between it and the outside of the blade is just slightly less than the depth of the groove, see Fig. 5.

CUT THE TENONS. To cut the tenon, make the first pass at the shoulder of the tenon, see Fig. 6a. Then slide the workpiece over to complete the tenon at the end.

Then flip the workpiece over to cut the other side. If necessary, raise the blade or move the fence and repeat the procedure until the tenon fits snug in the groove.

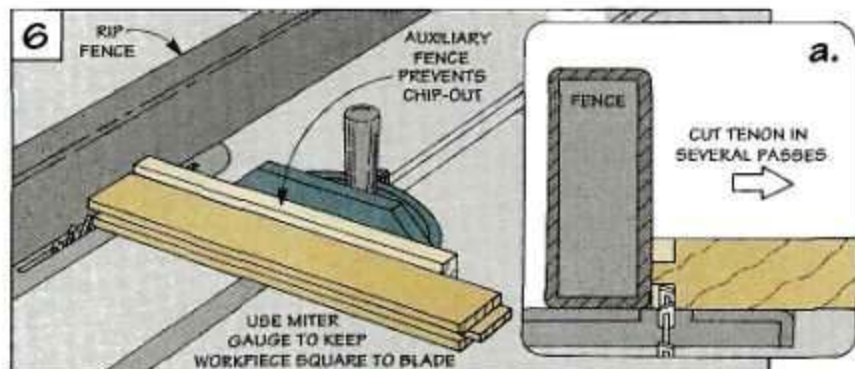
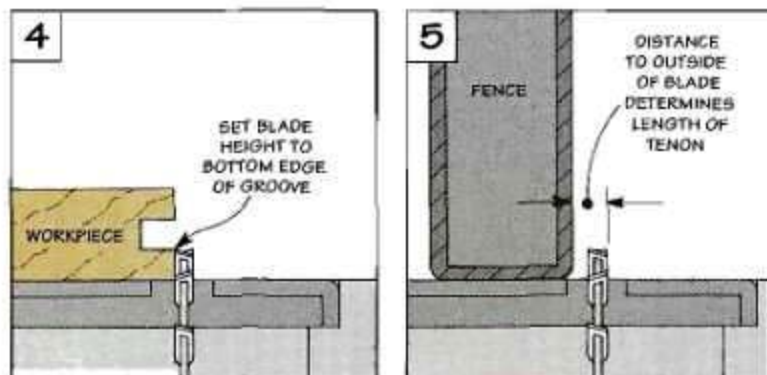

Adjustable Set-Up Gauge

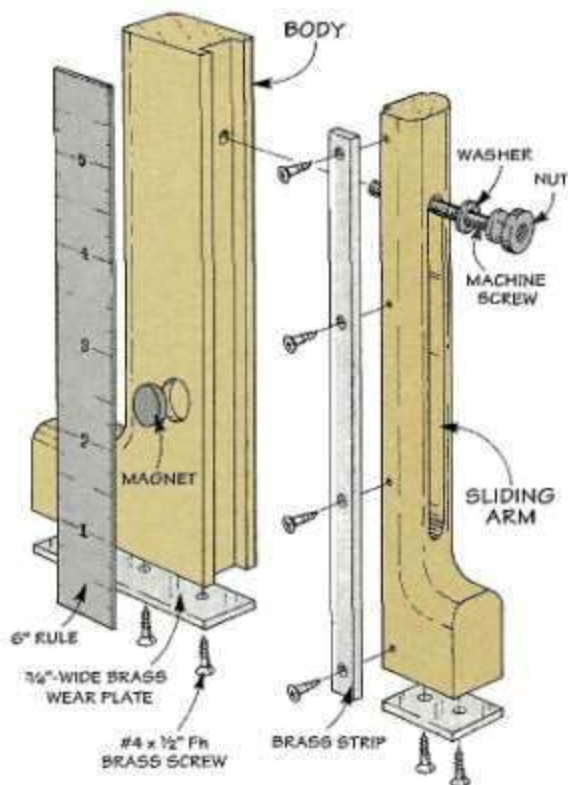

This adjustable set-up gauge solves both problems — it's precise and easy to read.

TWO PARTS. There are two basic parts to the gauge: a body, and a sliding arm, see drawing at left.

A groove in the body accepts a tongue that's cut in the arm. This allows the arm to slide up and down the body without twisting. Then the arm can be locked in place to take accurate readings.

PRECISION. What makes this gauge precise is an accurate rule. (For sources, see page 31.) The rule is held in place with a small magnet, see Exploded View.

This means you can "pop" the rule off and use it elsewhere. It also allows you to slide the rule and use it as a depth gauge, see center photo below.

EASY TO READ. The key to making the set-up gauge easy to read is the sliding arm. It's supported by the body and extends out over the bit or blade, see bottom left photo.

In use, the arm is adjusted so the bottom just touches the high point of the bit or blade. Then the brass strip on the sliding arm indicates the exact height of the bit or blade on the rule.

Setting a saw blade or router bit to an exact height (or depth) can be a challenge. The tricky part is getting an accurate reading off a rule or tape measure.

The curved profiles on many router bits make it almost impossible to get a precise measurement. And likewise, the angled teeth of a saw blade make it difficult to read.



▲ **Height:** Accurate height readings are easy with this gauge. That's because the arm extends over the blade.

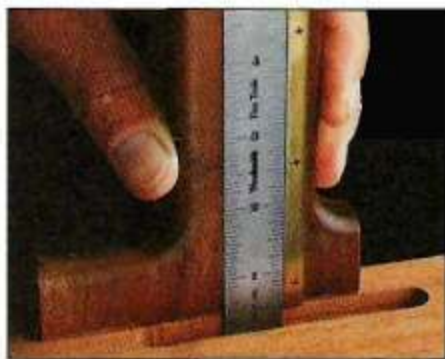

▲ **Depth:** The rule of the gauge is held in place with a magnet. This lets you slide it to check the depth of a mortise.



▲ **Distance:** The gauge can also be used to set a fence a precise distance away from a router bit or saw blade.

The Body

The set-up gauge consists of two main parts: a body, and a sliding arm, refer to Exploded View on the opposite page.

I started work on the L-shaped *body* by cutting a 3" wide by $5\frac{15}{16}$ " long blank, refer to Fig. 2.

GROOVE. Next, a shallow ($\frac{1}{8}$ "-deep) groove is cut in one edge of the body. This groove is one-half of a tongue and groove joint that allows the arm to slide up and down the body without twisting. The other half (the tongue) is cut on the sliding arm later.

It's easiest to rout the groove in the blank before the body is cut to shape. I did this on the router table, see Fig. 1.

To make sure the $\frac{1}{2}$ "-wide groove is centered on the stock, use a $\frac{3}{8}$ " straight bit and take two passes, flipping the workpiece end for end between passes, see Fig. 1a.

BODY SHAPE. After the groove is cut, lay out the shape of the body on the blank (note the location of the groove), see Fig. 2. Then drill a 1"-dia. hole and cut out the body with a sabre saw or band saw.

ROUND OVER EDGES. With the body cut out and sanded, the next step is to soften the outside edges, see Fig. 3. To do this, I used a $\frac{1}{4}$ " round-over bit in the

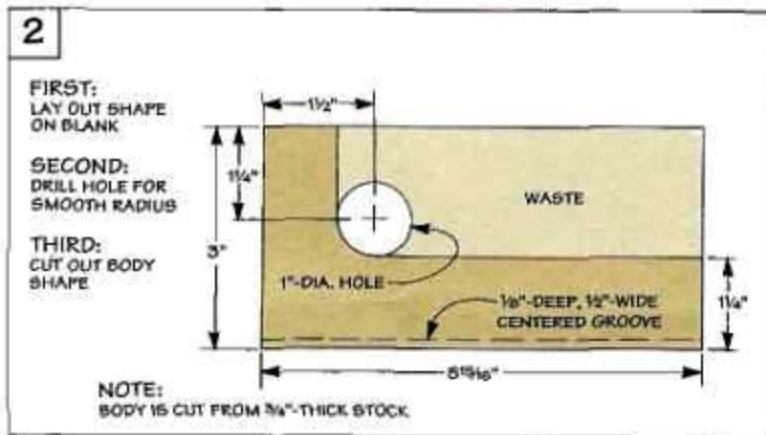
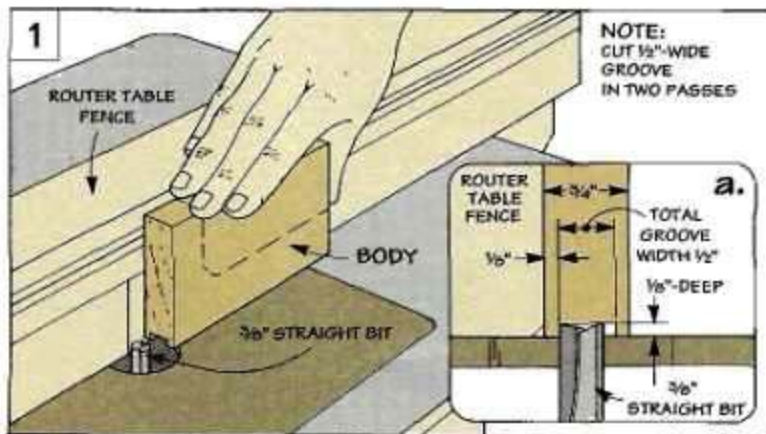

router table, see Fig. 3a.

ShopTip: To ensure a perfectly smooth round-over, first sand the sawn edges of the body, then rout the edge.

MAGNET. After the edges are rounded, lay out and drill a $\frac{1}{2}$ "-

dia. hole for the magnet that holds the metal rule in place, see Fig. 4. Note: To make sure the rule doesn't slip, I use a high-strength magnet. (See page 31 for sources.)

Finally, to complete the body, epoxy the magnet in the hole.

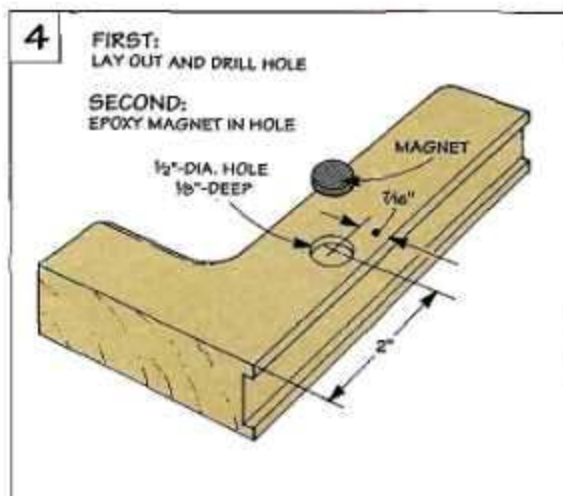
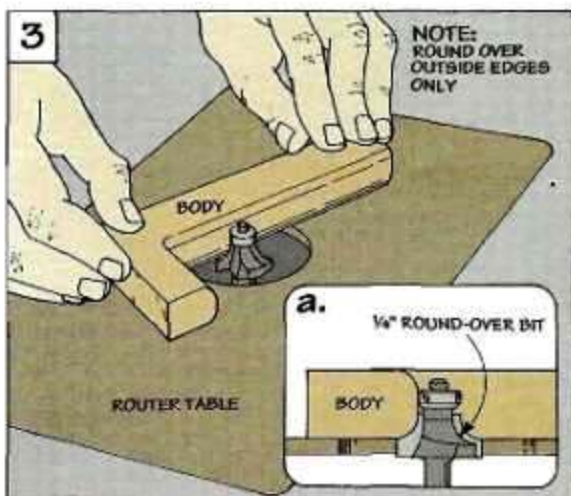

Hardware

- (1) Brass Strip $\frac{1}{4}$ " x .064 - 6"
- (1) Brass Strip $\frac{3}{4}$ " x .064 - 5"
- (1) Rare Earth Magnet $\frac{1}{2}$ "-dia.
- (1) 10-32 x $1\frac{3}{4}$ " Br. Machine Screw
- (1) 10-32 Brass Knurled Nut
- (1) No. 10 Brass Washer
- (8) No. 4 x $\frac{1}{2}$ " Brass Screws

The Sliding Arm

After completing the body of the set-up gauge, I started work on the *sliding arm*. Here again, I used an oversized blank, see Fig. 5.

CUT THE TONGUE. The first step is to cut a tongue (the other half of the tongue and groove joint) to fit the groove in the body. The important thing is to get a tight fit that still allows the arm to slide smoothly.

Just like the groove, I cut the tongue with a straight bit on the router table. But this time I moved the fence over the bit leaving $1/8"$ exposed, see Fig. 5a.

To do this, start with a test piece (the same thickness as the sliding arm). To form the tongue, take light passes on each edge until the tongue just fits in the groove. When the fit is snug, cut the tongue on the blank.

THE SHAPE. After the tongue is cut, lay out the shape of the sliding arm on the blank, see Fig. 5.

To make it safer to rout the sliding arm, I left a "handle" on both ends, refer to Figs. 6 and 7. To make the handles, drill a 1"-dia. hole and cut the blank to shape, refer to Fig. 5.

ROUND OVER EDGES. The next step is to round over the *outside* edges of the arm. (Note: Don't forget to sand the edges first.) To do this safely, hold the blank by the "handles" and rout a $1/4"$ round-over, see Fig. 6.

CUT THE SLOT. To lock the set-up gauge in position after you've taken a reading, a slot is cut in the sliding arm, see Fig. 7. Cutting the slot is a two-step process.

First, drill a pair of $1/4"$ -dia. holes to define the limits of the slot. Then rout out the waste. This can be done in a couple of passes with a $1/4"$ straight bit on the router table, see Fig. 7. (Here again, use the handles for safety.)

Finally, trim the sliding arm to its finished width and length, refer to Fig. 7a.

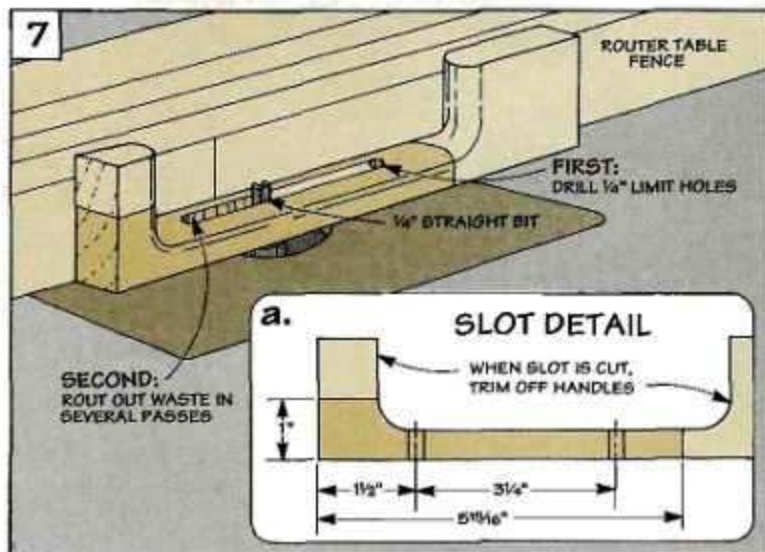
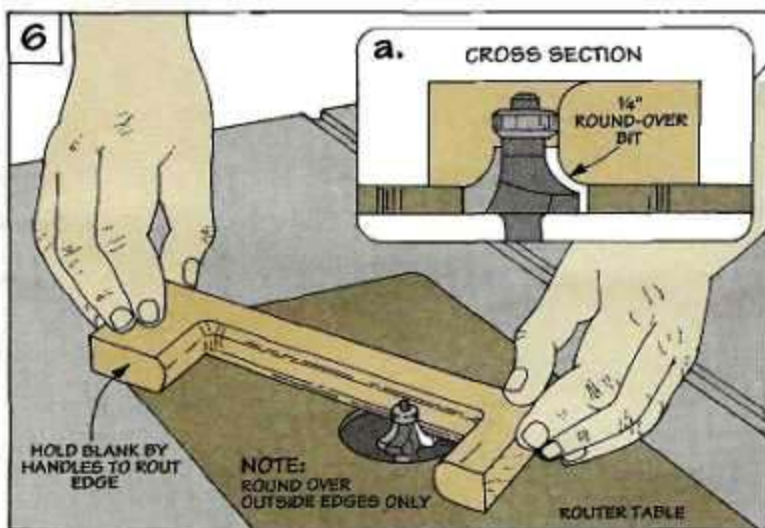
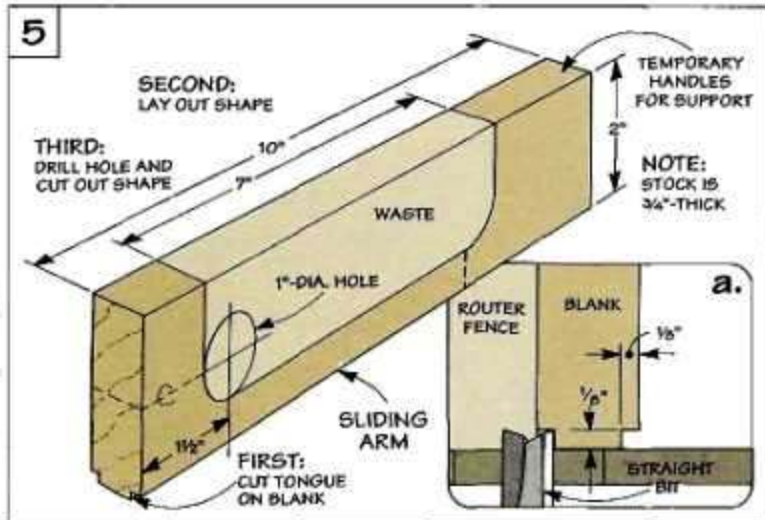

Assembly

The sliding arm is attached to the body with a brass machine screw, washer, and knurled nut, see Fig. 8.

BRASS SCREW. To locate a perfectly centered hole for the screw, I use a $\frac{1}{4}$ " brad point drill bit.

To do this, hold the arm and body together with the ends flush. Then insert the bit in the end of the slot and mark the center, see Fig. 8a.

Now drill a hole slightly less than the diameter of your screw.

ASSEMBLY. Assembly of the gauge is simple. First, the brass screw is screwed into the body. Then the head of the screw is cut off.

Next, slip the arm over the screw and add the washer. Now just thread on the knurled nut and file the screw flush, see Fig. 8b.

BRASS STRIPS. There are three brass strips on the gauge: two $\frac{3}{4}$ "-wide strips act as wear plates on the bottom, and a $\frac{1}{4}$ "-wide strip on the sliding arm to keep the rule aligned, see Fig. 9. (For sources of brass, see page 31.)

Since the $\frac{1}{4}$ "-wide strip is filed flush with the wear plate on the bottom, it acts as a pointer for the rule, see Fig. 9a. (For more on attaching brass, see box below.)

FINISH. After the brass is attached, wipe on a couple coats of tung oil. Finally, attach the rule to the gauge and it's ready to use.

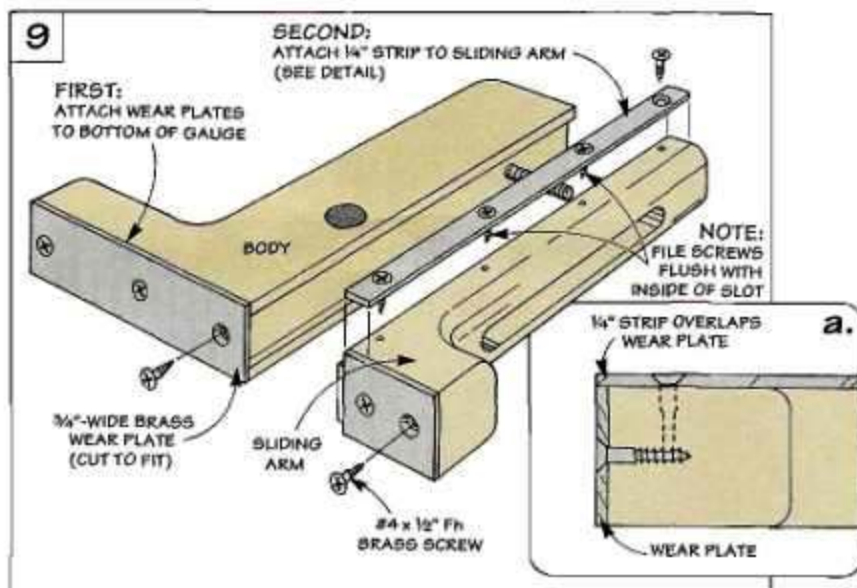
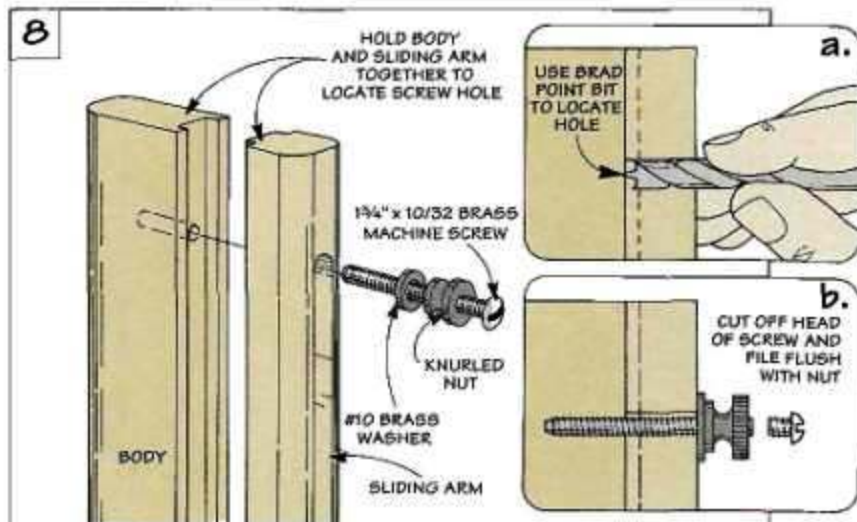

Attaching Brass to Wood

To attach brass to wood, I use "instant" glue and brass screws.

The "instant" glue holds the brass temporarily in place for drilling. Pilot and shank holes are drilled through the brass and then countersunk, see Fig. 1.

The screws keep the brass strips attached over time. After the screws are in place, the heads are filed off flush and sanded smooth, see Fig. 2.

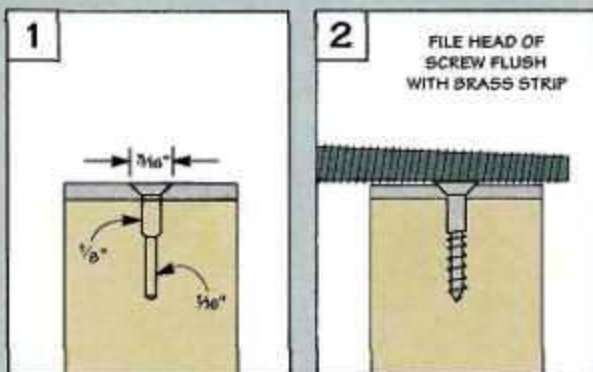

▲ A simple system for countersinking and filing a brass screw results in a fit that's almost invisible.

Shop Solutions

Drilling Tip

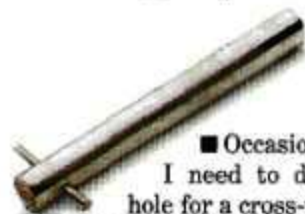

Occasionally I need to drill a hole for a cross-pin in a dowel, bolt, or steel rod, see photo above. The problem is the bit has a tendency to wander off the curved surface, so it's tough to center the hole exactly.

To pinpoint the hole and to prevent the tip of the bit from sliding off, I use a simple drilling jig. (Editor's Note: This jig is especially handy when drilling the hole needed on the drive center of the Turning Jig, see page 14.)

The jig is just a block of wood with a square end. The idea is to drill two holes in the block that are at 90° to each other.

To do this, position the end of

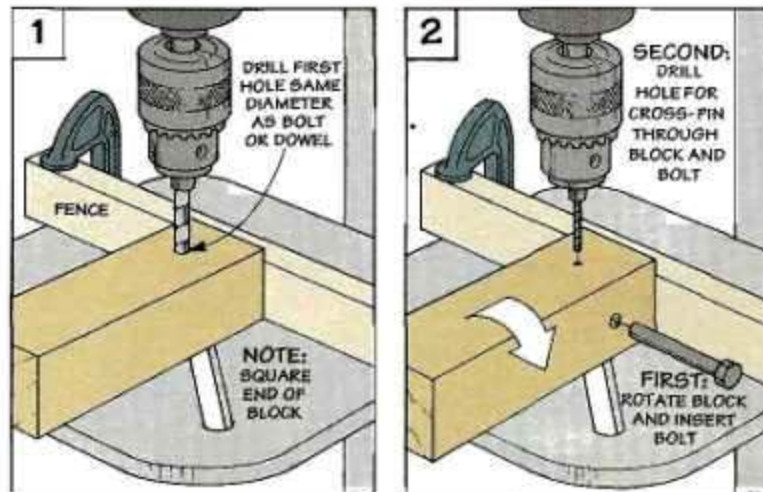

the block against a fence clamped to the drill press table. The first hole is drilled with a bit the same diameter as the bolt (or dowel), see Fig. 1. Next, rotate the block so it rests on its adjacent side, and insert the bolt, see Fig. 2.

Now drill the second hole the same size as the desired cross-pin hole in the bolt. The bit doesn't slip off. And the bolt is held securely by the block.

Darren Souier
Pride, Louisiana

Scroll Saw Blade Organizer

There's quite a variety in the width, thickness, and number of teeth per inch on scroll saw blades. But when you take them out of the package, the blades look remarkably alike.

To keep them separated, I built a scroll saw blade organizer, see drawing. It's made by gluing short pieces of 3/4" CPVC pipe into holes drilled in a couple of scrap pieces of wood.

The only trick is getting the holes to align. I taped the pieces together with double-sided tape before drilling the holes. To keep the blades from falling through, stop the holes halfway through the bottom piece, see Detail a.

Anthony Balkun
Wakefield, Rhode Island

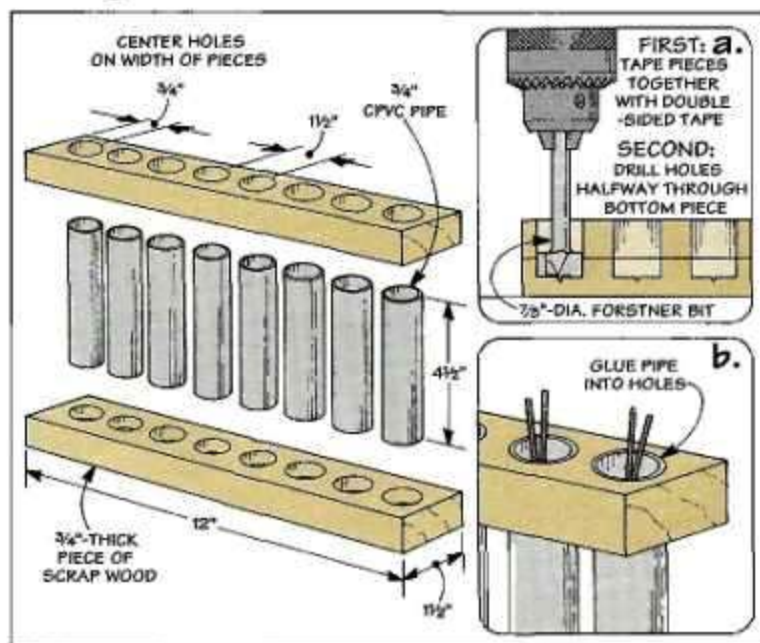

Turning Tip

■ Here's an old turner's trick I use before applying a finish to a project on a lathe.

When I'm done sanding, I press a handful of shavings up

against the spinning workpiece. This burnishes the wood and brings out a nice sheen in the turning.

Alan Miller
Sacramento, California



Squaring a Miter Gauge

■ I read your tip on setting the miter gauge on a table saw 90° to the blade. (Editor's Note: This tip appeared in Issue No. 1.)

I use a slightly different technique that doesn't waste as much wood. This technique requires taking a thin slice off two pieces at the same time, see Fig. 1.

First, stack one piece on top of the other. Then place the edges against the miter gauge and trim the ends, see Fig. 1a. Next, unfold the pieces like you would turn the pages of a book, see Fig. 2.

Now, set the pieces on edge (the edges that were against the miter gauge are down on the table), and slide the cut ends together, see Fig. 3.

If a gap appears at the bottom, the miter gauge needs to be adjusted clockwise, see Fig. 3a. If the opening is at the top, adjust the gauge counter-clockwise.

Note: The amount of error indicated by the gap is double the actual error.

John Plank
Waupun, Wisconsin

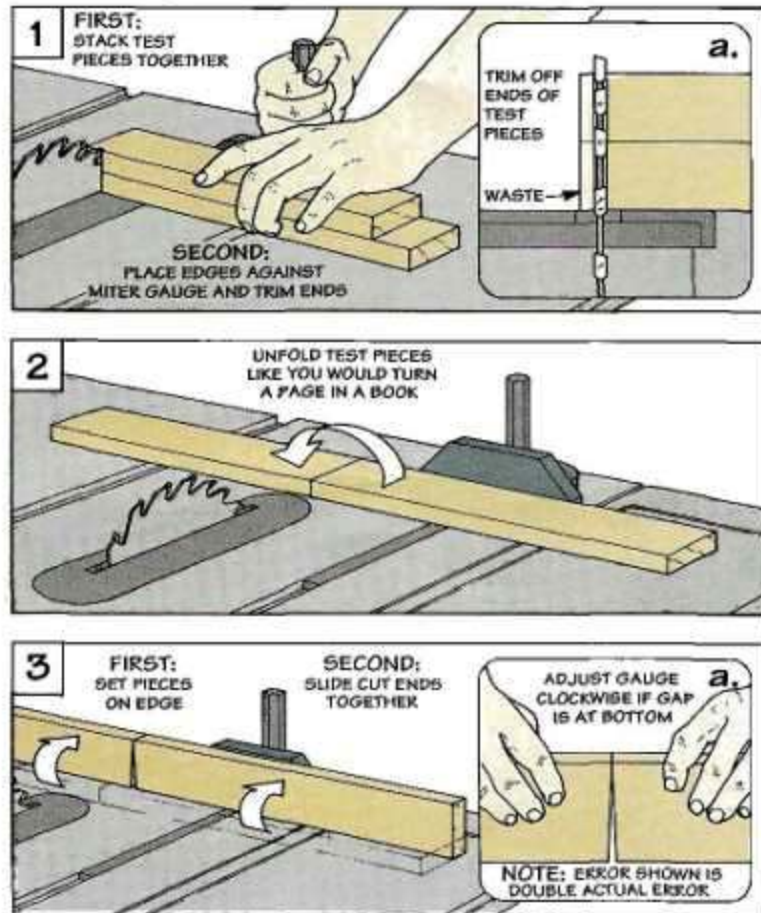

Clamp Pads

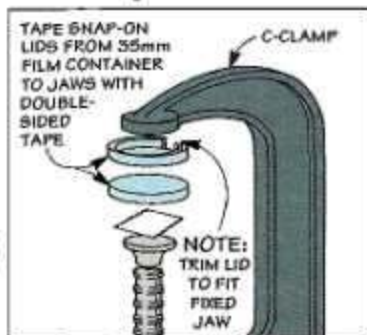

■ To keep from marring the surface of a workpiece when using C-clamps, I attach "pads" to the jaws of my clamps, see drawing.

The pads are snap-on lids from 35mm film containers that are taped to the jaws with carpet tape. To fit the fixed jaw, you'll need to trim the rim of the lid.

George Peterson
Englewood, Colorado

Send in Your Solutions

If you'd like to share original solutions to problems you've faced, send them to: *ShopNotes*, Attn: Shop Solutions, 2200 Grand Ave., Des Moines, IA 50312.

We'll pay up to \$200 depending on the published length. Send an explanation along with a photo or sketch. Include a daytime phone number so we can call you if we have questions.

Lumber Thickness

The terms used to describe lumber thickness can be confusing. But once you break the "code" it's easy to understand.

■ I've often heard other woodworkers talk about 4/4, 5/4, and 8/4 stock. What do these designations mean?

First of all, these "quarter" designations stand for the thickness of hardwood lumber as it's cut into rough boards.

QUARTERS. Traditionally, hardwood lumber is referred to by its rough thickness, in 1/4" increments. So a 1"-thick rough board is called 4/4 (four-quarter), and a 1 1/4"-thick rough-sawn board is called 5/4 (five-quarter).

However, this designation is not the actual thickness of the lumber when it's surfaced (planed) and sold to the customer. This is where the confusion begins.

After the lumber is surfaced, it still retains the "quarter" terminology even though the actual thickness has changed.

GUIDELINES. In order to assure the customer that he's actually comparing "apples to apples" from one yard to the other, the National Hardwood Lumber As-



▲ Lumber mills and distributors use large planers to surface rough stock before it's sold. This removes the saw marks and leaves it uniform in thickness.

sociation has established a set of guidelines for the thickness of surfaced lumber, see chart below.

However, these specifications are guidelines — not the law. Lumberyards or retail outlets may not follow these guidelines.

Some 4/4 stock is surfaced to 13/16" according to the guidelines. But some mills have settled on 25/32" because they've found that it yields more saleable lumber.

OTHER STANDARDS. To add to the confusion, hardwoods and softwoods have different stand-

ards for surfaced thickness. Some stores surface hardwood down to 3/4" because that's what's used with softwood.

■ I've seen lumber sold as S2S and S4S. What do these letters and numbers mean?

These letters and numbers designate how many surfaces of the board have been planed or cut square. The "S" means surfaced. The numbers — 1, 2, 3, and 4 refer to the number of

surfaces cut or planed.

For example, a board marked S4S means that it has been surfaced on both faces and jointed or straight-line ripped on both edges. Almost every piece of softwood lumber sold at home centers has been surfaced on all four (S4S), like a 1x4.

Occasionally, you'll find hardwood lumber that's been surfaced on just two sides (S2S). This doesn't mean it's inferior — just milled less. And less milling usually means a lower price.

Standards for Hardwood Lumber

Rough Thickness	Quarter Designation	Surfaced Thickness
5/8"	5/8" *	7/16"
3/4"	3/4" *	9/16"
1"	4/4	13/16"
1 1/4"	5/4	1 1/16"
1 1/2"	6/4	1 5/16"
2"	8/4	1 3/4"

* Rough lumber less than 1" is expressed in inches

Lumber Questions?

Identifying, selecting, and buying materials for your workshop projects can be a bit confusing.

If you have any questions about lumber or other project materials, send them to: ShopNotes, Attn: Lumberyard, 2200 Grand Ave., Des Moines, IA 50312.

Please include a daytime phone number so we can call you if necessary.

Sources

ShopNotes Project Supplies is offering some of the hardware and supplies needed for the projects in this issue.

We've also put together a list of other mail order sources that have the same or similar hardware and supplies.

MITER BOX

There is a hardware kit available for the shop-built Miter Box shown on page 4. The kit includes all of the hardware necessary to build the Miter Box. It does not include the hand saw, the wood, or the Masonite.

S6805-100 Miter Box Hardware Kit.....\$9.95

ROLL-AROUND SHOP CART

ShopNotes Project Supplies is offering a kit that contains all of the hardware needed to build the Shop Cart shown on page 16.

Similar hardware can be found locally or from the mail order sources listed below.

S6805-200 Shop Cart Hardware Kit.....\$69.95

DRAWER SLIDES & CASTERS

The drawer slides and locking casters that we used on the Shop

Cart are available separately.

The drawer slides are 18" full extension slides and are rated at a 75 lb. capacity. One pair is needed for each drawer or tray.

S1006-211 One Pair 18" Drawer Slides \$5.95

We used two pairs of 3" locking casters on the Shop Cart.

S747-211 One Pair 3" Locking Casters.....\$19.95

SET-UP GAUGE

If you would like to purchase all of the hardware needed to make the Adjustable Set-Up Gauge shown on page 24, there is a kit available. The kit includes all of the brass parts, screws, and high-strength magnet. (Brass strips like the ones we used can also be found at local hobby shops.)

You'll need to supply your own metal rule and wood. Note: If you don't have a metal rule, one is available separately.

S6805-300 Set-up Gauge Hardware Kit.....\$14.95

MAGNET

The only unusual piece of hardware used in making the Set-Up Gauge is the magnet. We used a small, but very strong, magnet

called a rare earth magnet. If you want to purchase the magnet only, it is available through *ShopNotes Project Supplies* and through the source listed below.

S1001-250 Rare Earth Magnet.....\$10.95

6" RULE

The Set-up Gauge shown on page 24 is designed to work with any 6" metal (not aluminum) rule. The rule we used is one we had manufactured to our own specifications. One side is graduated in 1/16" increments the other side has 1/8" increments.

S701-116 Woodworker's Rule No. 601.....\$9.95

Note: Similar rules are available from some of the mail order sources listed below.

GLUE

We used a special glue to temporarily hold the brass onto the Set-Up Gauge. The glue we used has a slower setting time than most instant glues. This type of glue is also available from some of the mail order sources listed below.

S4010-210 Special-T Instant Glue (2 oz.).....\$9.95

S4010-220 Solvent\$4.95

MAIL ORDER SOURCES

Similar hardware and supplies may be found in the following catalogs. Please call each company for a catalog or for ordering information.

Edmund Scientific

609-573-6250
Rare Earth Magnets

Constantine's

800-223-8087
Drawer Slides, Locking Casters, Instant Glue

Garrett Wade

800-221-2942
Instant Glue, Metal Rule

Trend-Lines

800-767-9999
Drawer Slides

Woodcraft

800-225-1153
Drawer Slides, Instant Glue, Metal Rule

The Woodworkers' Store

612-428-2199
Drawer Slides, Locking Casters, Metal Rule, Instant Glue

Woodworker's Supply

800-645-9292
Drawer Slides, Locking Casters, Instant Glue

Shopsmith/Woodworking Unlimited

800-543-7586
Drawer Slides, Instant Glue, Metal Rule

ORDER INFORMATION

BY MAIL

To order by mail, use the form enclosed with a current issue. The order form includes information on handling and shipping charges, and sales tax. Send your mail order to:

**ShopNotes
Project Supplies
P.O. Box 842
Des Moines, IA 50304**

BY PHONE

For fastest service use our Toll Free order line. Open Monday through Friday, 7:00 AM to 7:00 PM Central Time.

Before calling, have your VISA, MasterCard, or Discover Card ready.

1-800-444-7527

Note: Prices subject to change after Nov. 1, 1992.

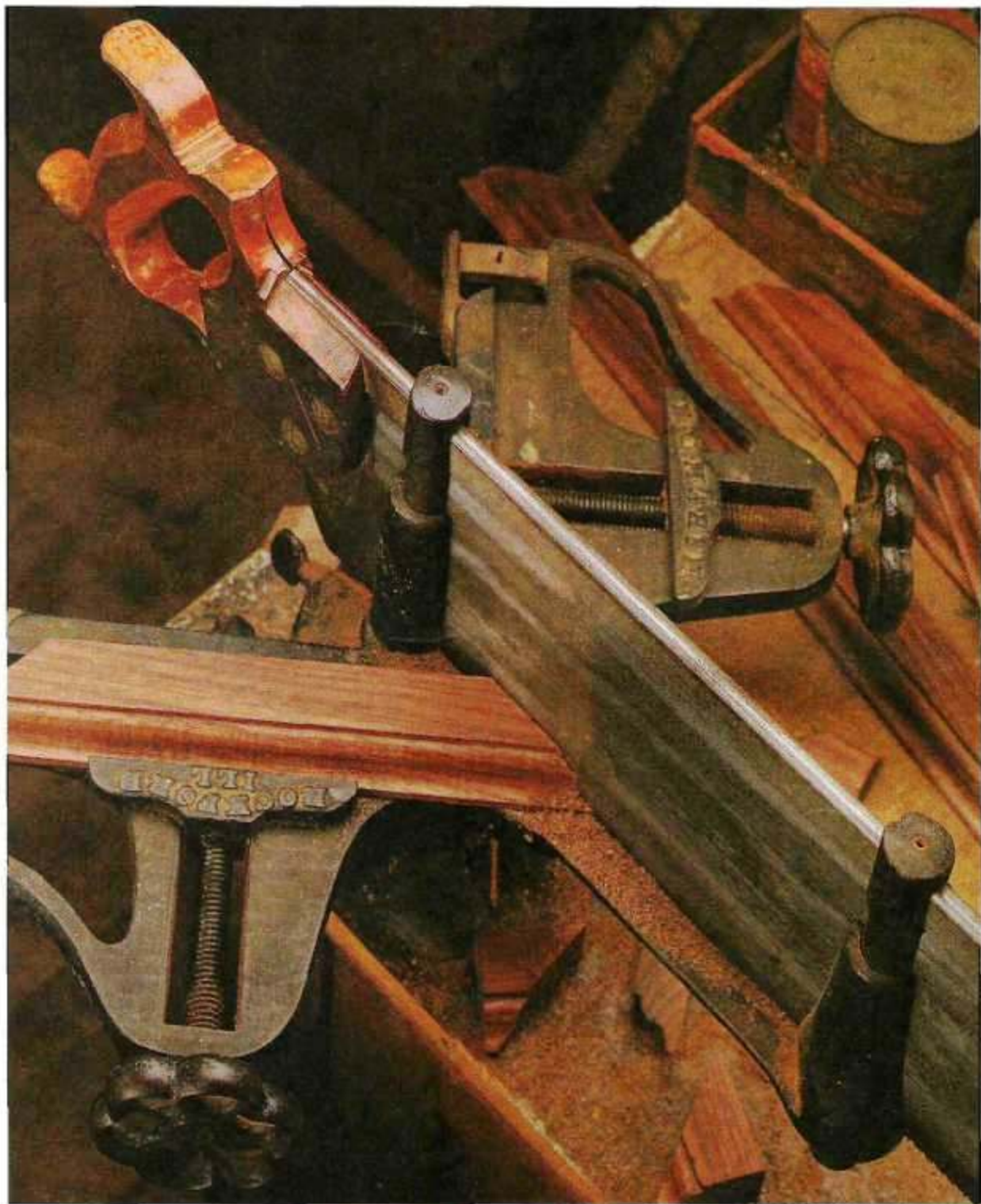

Scenes From the Shop

Weighing in at over 40 pounds, this cast iron miter machine was used by cabinetmakers to cut perfect 45° miters. The workpiece is first positioned against the

rear jaw. Then the hand wheel is turned to lock it in place. The miter saw rides in a set of guides that guarantees both precision and a smooth chatter-free cut.