

TIPS • TOOLS • TECHNIQUES

# ShopNotes™

\$4.95

Issue 4



- Shop-Built Panel Saw
- Hinge Mortising Jig

- Thickness Sanding Jig
- Sharpening Hand Saws



# ShopNotes

Issue 4

JULY 1992

**EDITOR** Donald B. Peschke

**EDITORIAL DIRECTOR** Douglas L. Hicks

**MANAGING EDITOR** Terry J. Strohmman

**ASSISTANT EDITORS** Richard S. Peters  
Tim Robertson

**CREATIVE DIRECTOR** Ted Kralcoek

**ART DIRECTOR** Cary Christensen

**ILLUSTRATORS** Kurt Schultz  
Will Niskanen  
Roger Reiland

**DESIGN DIRECTOR** Ken Munkel

**DESIGNER** Jan Hale Svec

**PHOTOGRAPHER** Crayola England

**SHOP MANAGER** Steve Curtis

**CIRCULATION DIRECTOR** Liz Bredeson

**SUBSCRIPTION MANAGER** Phyllis Jessen

**CIRCULATION ANALYST** Jim Woodson

**NEWSSTAND SALES** Kent A. Buckton

**CONTROLLER** Paul E. Gray

**ACCOUNTING** Linda O'Rourke

**BOOKKEEPING** Julianne Spears

**NETWORK ADMIN.** Douglas M. Lidster

**ADMINISTRATIVE ASSTS.** Cheryl Scott  
Julia Fish

**BUILDING MAINTENANCE** Ken Griffith

**MARKETING DIRECTOR** Robert Murry

**SHOP SUPPLIES ART DIR.** Cindy Jackson

**CUSTOMER SERVICE MGR.** Laura McNelly

**PROJECT SUPPLIES** Leslie Ann Gearhart  
Linda Jones

**TECHNICAL SUPPORT** Jonathan Garbison

**SYSTEMS OPERATOR** Linda Morrow

**RECEPTIONIST** Keri Lee

#### CUSTOMER SERVICE

Jennie Enos (Supr.), Jeff Janes, Joy Johnson, Sara Johnson, Ami Blanshan

#### SHIPPING DEPARTMENT

Jerry Carson (Supr.), Gloria Sheehan, Ronald Long, Don McVey, Chuck Carlson

ShopNotes is published bimonthly (January, March, May, July, September, November) by Woodsmith Corporation, 2200 Grand Ave., Des Moines, IA 50312. Printed in U.S.A.

ShopNotes is a trademark of Woodsmith Corporation. ©Copyright 1992 by Woodsmith Corporation. All rights reserved.

Subscriptions: Single Copy, \$4.95. One year subscription (6 issues), \$19.95. Two years (12 issues), \$36.95. Canada/Foreign, add \$4.00 per year.

Second Class Postage Pending at Des Moines, IA and at additional offices.

Postmaster: Send change of address to ShopNotes, Box 11204, Des Moines, IA 50310-1204

Subscription Questions? Call 1-800-333-5854, 8am to 5pm, Central Time, weekdays.

## EDITOR'S NOTE

**Y**ou can imagine my surprise at the cost of the panel saw we were looking at purchasing for the shop — over \$1000. It's a nice piece of equipment, but that's a lot of money to spend.

Panel saws are used to cut sheet goods (plywood, etc.) down to manageable size. It's one of those tools that you don't think you need . . . until you have the chance to use one. Then it sure would be nice to have in the shop.

The biggest benefit is that you can easily cut 4x8 sheets down to size — by yourself.

The cost of this type of saw usually puts it out of range for most home shops. In almost every instance like this, my first thought is, "Okay, let's save money by building one ourselves."

It took about five weeks to work out the design details for the Panel Saw. Hardware turned out to be one of the key elements in the design.

It wasn't that we needed special, hard-to-find hardware. The tricky part was coming up with ways of using common hardware in rather uncommon applications.

In the end it worked out great — we got the panel saw we wanted for the shop. And only spent about \$250 (\$100 for materials and \$150 on hardware).

**HINGE MORTISES.** While the panel saw is an impressive piece of equipment, it may be too large for some workshops. On a smaller scale is the hinge mortise jig in this issue.

Setting hinges is one of the final critical parts of cabinetmaking. It can break a project if the

hinges are misaligned.

Correctly positioning the hinge in the first place remains the key. Then an accurate mortise is cut to match the hinge. The key word is *accurate*. If the mortise is off, you've got problems.

That's where this jig comes in. We devised an adjustable jig that lets you set the size of the mortise to match exactly the size of the hinge.

All you need is a router and a *pattern bit* to rout perfect hinge mortises. (A pattern bit is a straight bit with a guide bearing on the *shank*, instead of on the end, like a flush trim bit.)

**SHARPENING.** Sometimes the idea for an article comes in a rather round-about way. Recently, I brought a couple of old hand saws into the shop to sharpen. (One of them appears on the back cover.)

The sound of filing the saw teeth brought several people into the shop.

Their reaction seemed to be the same — wouldn't it be easier and faster to take the saw to a commercial saw sharpening shop? Easier perhaps, but not faster.

To prove the point, I gave a quick demonstration on how to sharpen a handsaw.

All you need is a few simple tools and a little patience. The trick is to let the saw be your guide. And to let the triangular saw file do all the work.

Over the next few days our workshop was full of people bringing their dull saws back to life. The result of all this activity is the saw sharpening article on page 12.

# Contents

## Hinge Mortising Jig \_\_\_\_\_ 4

All it takes to make perfect hinge mortises is a router and this simple jig.

## Thickness Sanding Jig \_\_\_\_\_ 8

Sanding thin wood so it's smooth and uniform in thickness is easy with this jig for your drill press.

## Shop-Made Drum Sander \_\_\_\_\_ 11

A bolt, some toy wheels, and a piece of PVC pipe are all you need to make your own drum sander.

## Sharpening Hand Saws \_\_\_\_\_ 12

There's nothing mysterious to sharpening a hand saw. All it takes is a few simple tools and a little practice.

## Panel Saw \_\_\_\_\_ 16

This shop-built panel saw allows one person to easily crosscut or rip a full sheet of plywood or Masonite. It's made with common materials and hardware.

## Panel Saw Tune-Up \_\_\_\_\_ 24

Tips on adjusting the panel saw to make precise cuts every time.

## Motor Vibration \_\_\_\_\_ 26

Some quick tips to reduce troublesome vibration in belt-driven machines.

## Shop Solutions \_\_\_\_\_ 28

Five shop-tested tips: Saw Blade Storage Rack, Edge Jointing Tip, Installing Threaded Inserts, Clamping Irregular Shapes, and File Handles.

## Combination Screws \_\_\_\_\_ 30

A unique thread design and recess in the head make these screws the perfect choice for the shop.

## Sources \_\_\_\_\_ 31

Hardware, project supplies, and mail order sources for the projects in this issue.

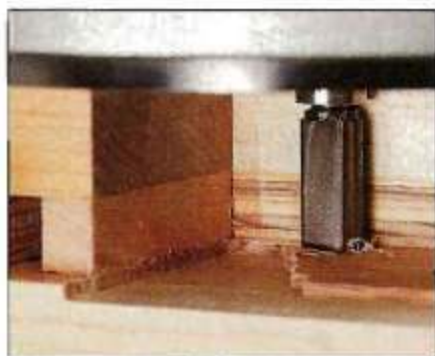

Hinge Mortising Jig page 4



Thickness Sanding Jig page 8



Sharpening Saws page 12



Panel Saw page 16



# Hinge Mortising Jig

**Y**ou can rout perfect hinge mortises every time using your router and this mortising jig. The key to making this jig work is the router bit that's used to cut the mortises — a pattern bit, see box below.

**PATTERN BIT.** A pattern bit is similar to a flush trim bit except the bearing is mounted on the *shaft* rather than the end of the bit (for sources of pattern bits, see page 31). With the bearing up on the shaft like this, the bit can be plunged into the workpiece — perfect for cutting mortises.

**ADJUSTABLE GUIDES.** When a pattern bit is used with this jig, the bearing rides against a set of guides that are adjusted to match the *exact* dimensions of your hinge, see Exploded View. (For

step-by-step instructions on how to use this jig, see page 7.)

As the bearing tracks along these guides, the bit cuts a *perfect* mortise, refer to photo on page 7. Note: When used with a 1/2" pattern bit, the end guides

can be adjusted to cut mortises ranging in length from 1/2" to 4".

## BASE

I started work on the hinge mortising jig by making a *base* (A). It's just a "U"-shaped piece of

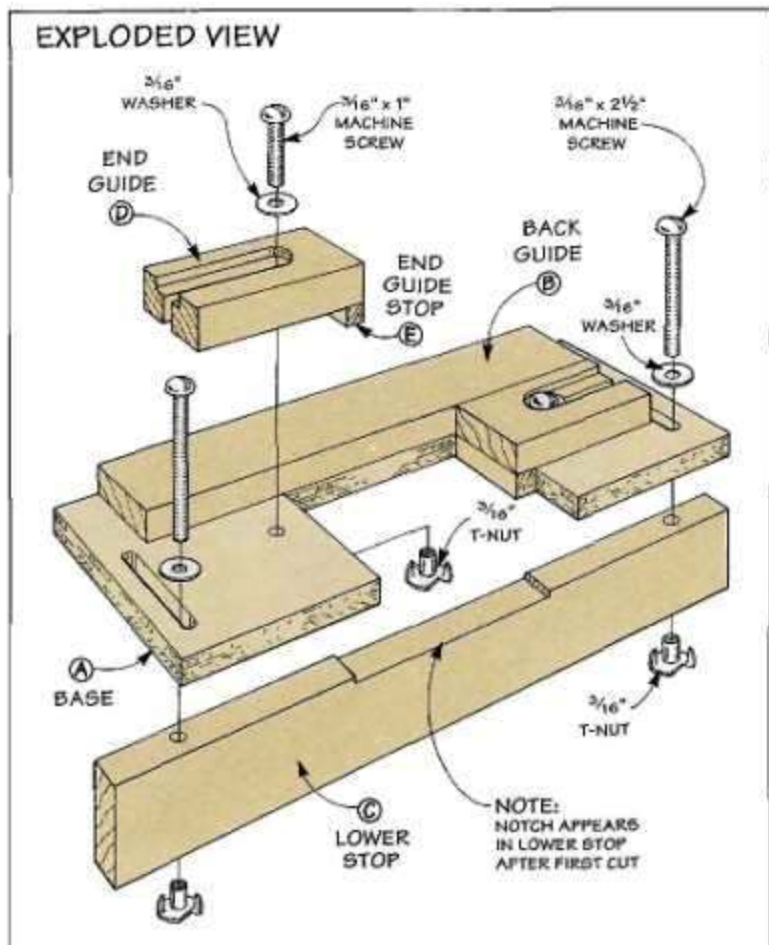
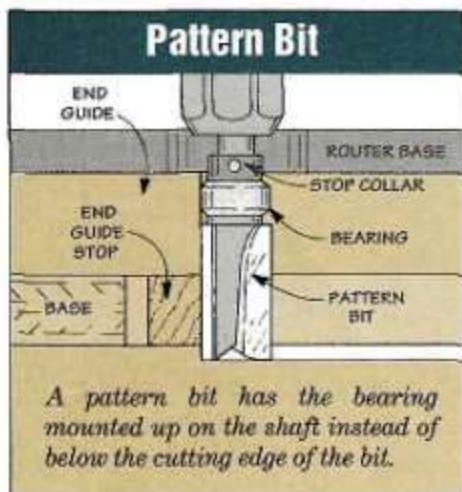

1/2"-thick plywood that supports the guides, see Fig. 1. The "U" is formed by cutting a notch in one side. This notch is the opening for the pattern bit.

**BACK GUIDE.** After the notch is cut, the next step is to cut a *back guide* (B) from 3/4"-thick hardwood, see Fig. 1.

This back guide provides a surface for the bearing of the pattern bit to ride against as it cuts the back of the mortise. And it helps align the end guides (which are installed later).

Once the back guide is cut, center it on the base and glue it flush along the back edge of the notch, see Fig. 1.

**LOWER STOP.** After gluing the back guide in place, I added a *lower stop* (C), refer to Fig. 3. Once this stop is cut to size, it's attached to the base with a pair of machine screws and T-nuts. The screws are mounted in slots to allow you to position the back guide for different width hinges, see Fig. 2.

To make the slots, first drill start and stop holes. Then clean out the waste on the router table, see Figs. 2 and 2a.

After the slots are cut in the base, locate the screw holes in the

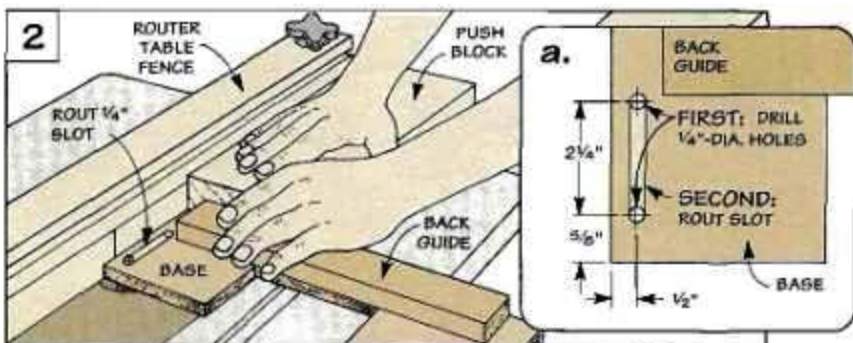
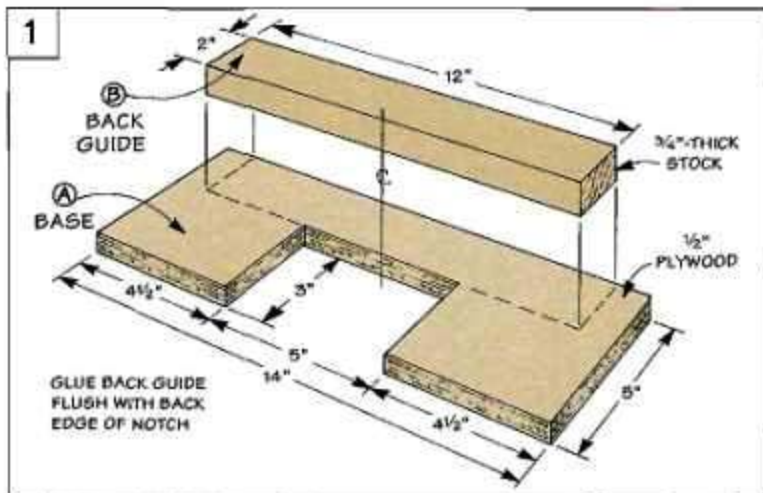

stop for the T-nuts. To do this, center the base on the lower stop and make a mark, see Fig. 3a.

Then drill holes and insert the T-nuts, see Fig. 3b. Finally, screw the lower stop to the base.

In use, the stop is clamped to the workpiece. Then the screws are loosened and the base is adjusted so the back guide aligns with layout lines for the hinge mortise. (For more on this, see page 7.)

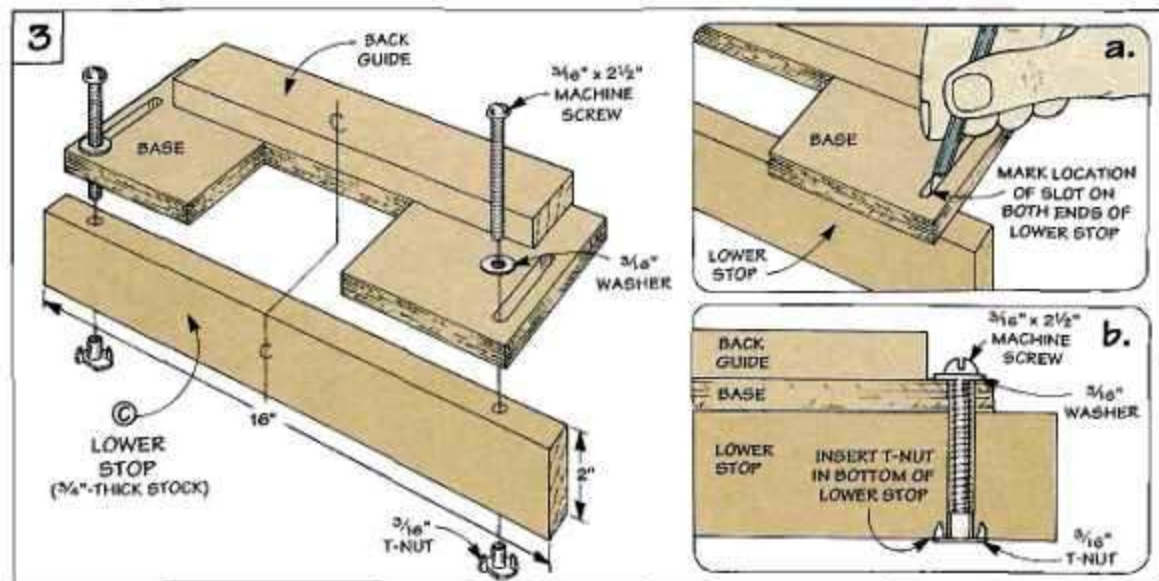

# End Guides

Once the lower stop is attached to the base, work can begin on the end guides, see Exploded View. The end guides are L-shaped pieces attached to the base with machine screws. A slot in each guide allows adjustment for different length hinges.

To make both the *end guides* (D), start by cutting an extra long blank from  $\frac{3}{4}$ "-thick stock, see Fig. 4.

**STEPPED SLOTS.** Then, to allow the base of the router to slide over the screws and washers that hold down the end guides, I routed stepped slots down the center of each guide, see Fig. 4.

To do this, adjust the fence on your router table so a  $\frac{3}{4}$ " straight bit is centered on the width of the blank, see Fig. 5. Then clamp a stop block to the fence  $2\frac{7}{8}$ " away from the back edge of the bit, see Fig. 5a.

Now push the blank into the bit until it hits the stop. Turn off the router. Then, flip the piece around and rout the other end.

To complete the slot, just remove the  $\frac{3}{4}$ " bit and replace it with a  $\frac{1}{4}$ " straight bit — you don't have to reposition the stop or the fence. Just make a couple of passes using the same procedure as before, see Fig. 5b.

**CUT TO LENGTH.** Now that the slots are routed, cut the end

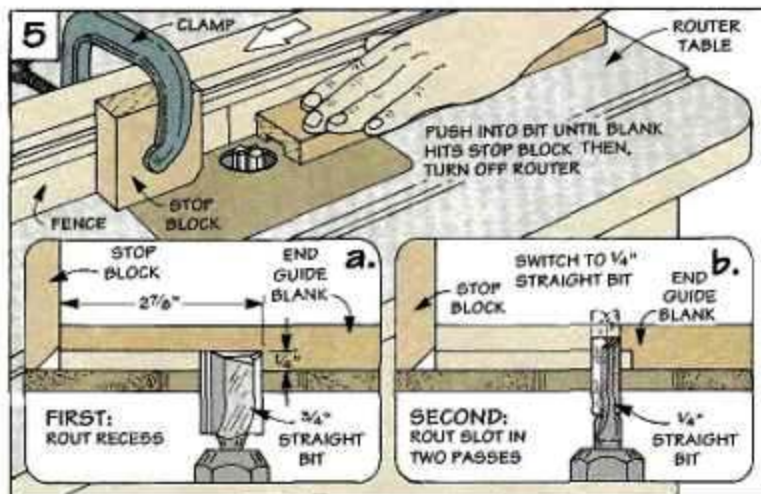
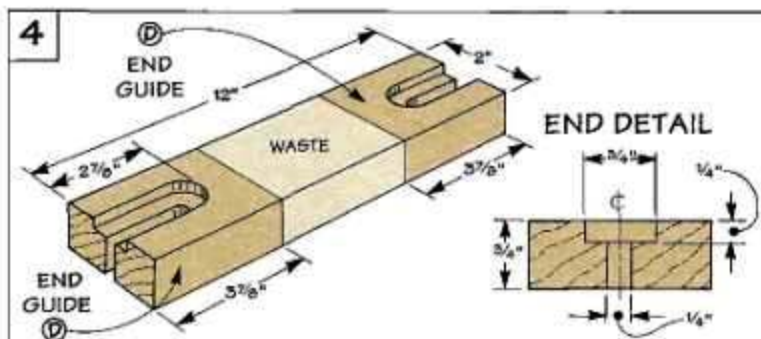

guides (D) to length, refer to Fig. 4. And then glue on an *end guide stop* (E) to each end guide (D), see Fig. 6.

**T-NUTS.** Each slotted end guide is mounted to the base with a machine screw and a T-nut, see Fig. 7. To locate the holes for the T-nuts, place the end guides on the base

with the end guide stops (E) against the notch. Then mark the slot positions and drill counterbored holes near the closed end of the slot, see Figs. 7a and 7b.

Finally, pound a T-nut in from the *backside* of the base and screw the end guides in place, see Fig. 7b.

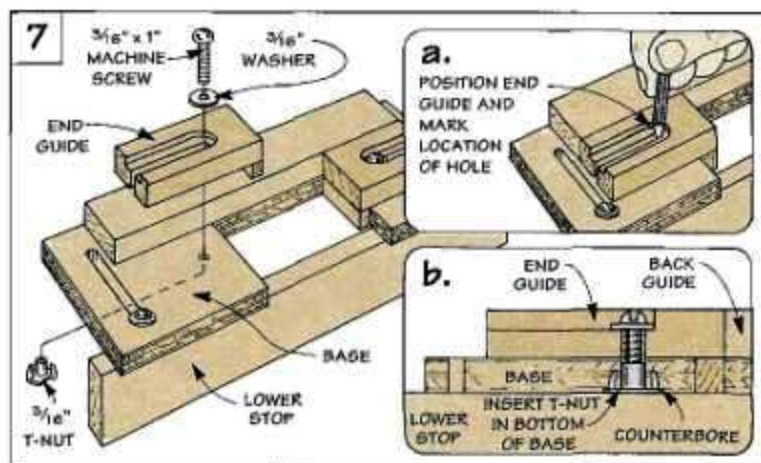
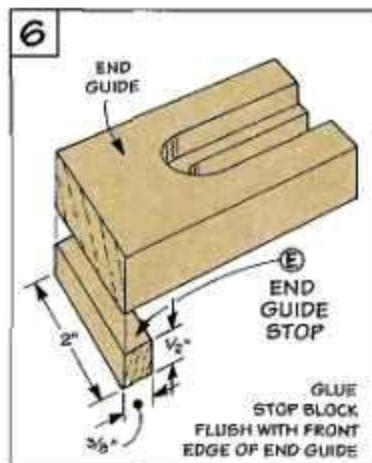

## Routing Mortises Step-by-Step

The mortising jig is easy to use. The first thing to do is mark out the location of the hinge. I like to use a knife to mark a precise line around the edges of the hinge.

The next step is to clamp the jig to your workpiece with C-clamps. Then, adjust the guides to match the width and length of your hinge, see Steps 1 and 2.

**SET DEPTH OF BIT.** Once the guides are adjusted, set the router bit to the correct depth and rout out the mortise, see Step 3. (Note: This will also rout a notch in the lower stop.)

**SQUARE UP CORNERS.** Finally, square up the corners. Just leave the jig in place for this, it acts as a guide for the chisel, see Step 4.

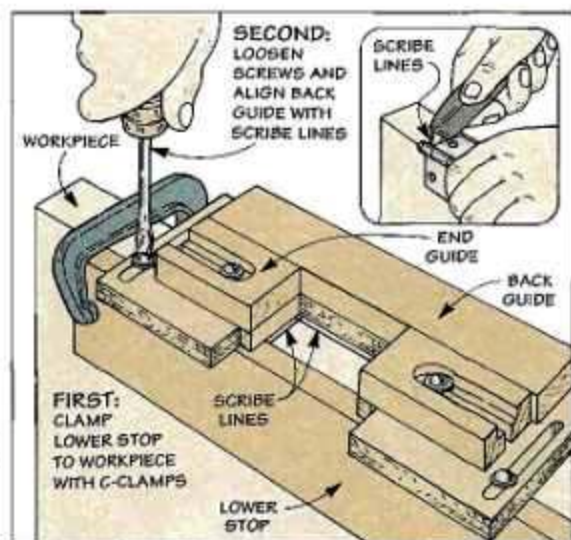

**Step 1: Adjust the Width.** First, clamp jig over layout lines. Loosen screws in lower stop and position base so back guide aligns with scribed lines.

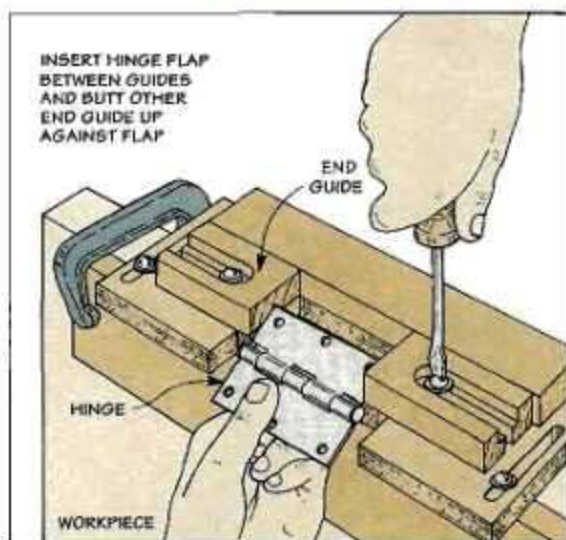

**Step 2: Adjust the Length.** Position one end guide on the layout line. Then, place a hinge flap between the guides and adjust the other end guide.

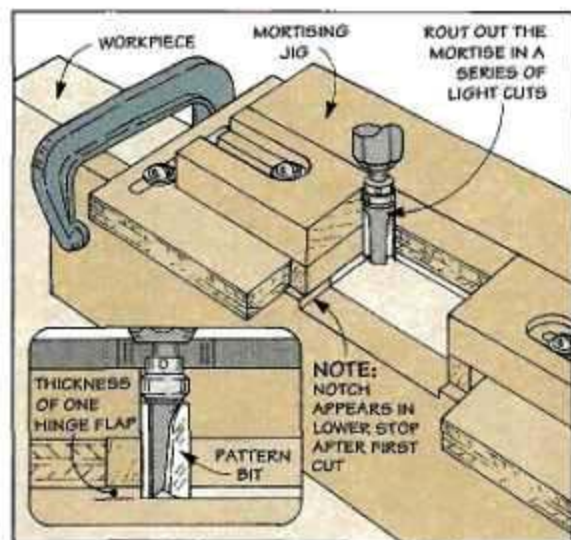

**Step 3: Rout the Mortise.** Adjust a pattern bit to cut less than the thickness of a hinge flap. Make light passes until the desired depth is reached.

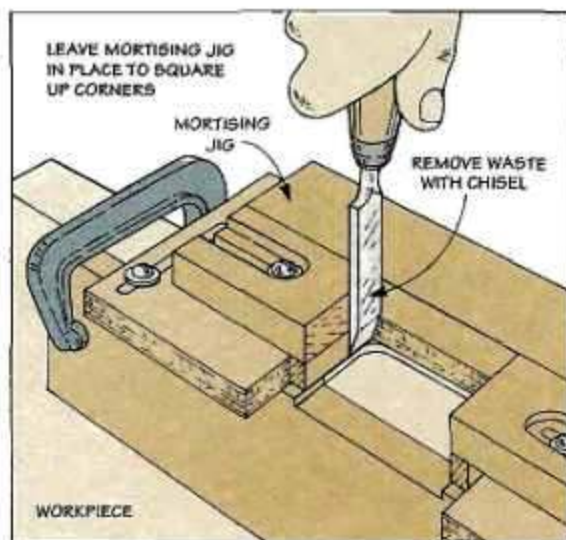

**Step 4: Square up the Corners.** Leave the mortising jig clamped in place and square up the corners of the mortise with a sharp chisel.



# Thickness Sanding Jig

**A** quick way to make thin stock is to resaw a board and then sand away the marks left by the saw. (Resawing reduces the thickness of a board by cutting it into thin pieces.) The trick is to remove the marks *and* leave the stock uniform in thickness.

To solve this problem, I built this thickness sanding jig, see photo. It clamps to the drill press table and uses a drum sander to sand the workpiece. (To make your own drum sander, see page 11.)

The sanding jig consists of three main parts: a base, a fence assembly, and a dust collector.

## BASE

To provide a smooth, flat surface for attaching the fence assembly and dust collector, I cut a square plywood *base* (A), see the Exploded View.

A hole in the center of the base forms a recess for the drum sander, see Detail in Exploded View. Note: The hole is sized  $\frac{1}{4}$ "

larger than the sanding drum.

## FENCE ASSEMBLY

Once the base is complete, the next step is to make the fence assembly, see Fig. 1. It's made up of three pieces: a plywood fence, a micro-adjuster, and a fence support. refer to Exploded View.

By adjusting the space between the fence and the drum you can sand stock up to  $\frac{1}{2}$ "-thick. (Note: The width of the stock is limited by the height of the drum.)

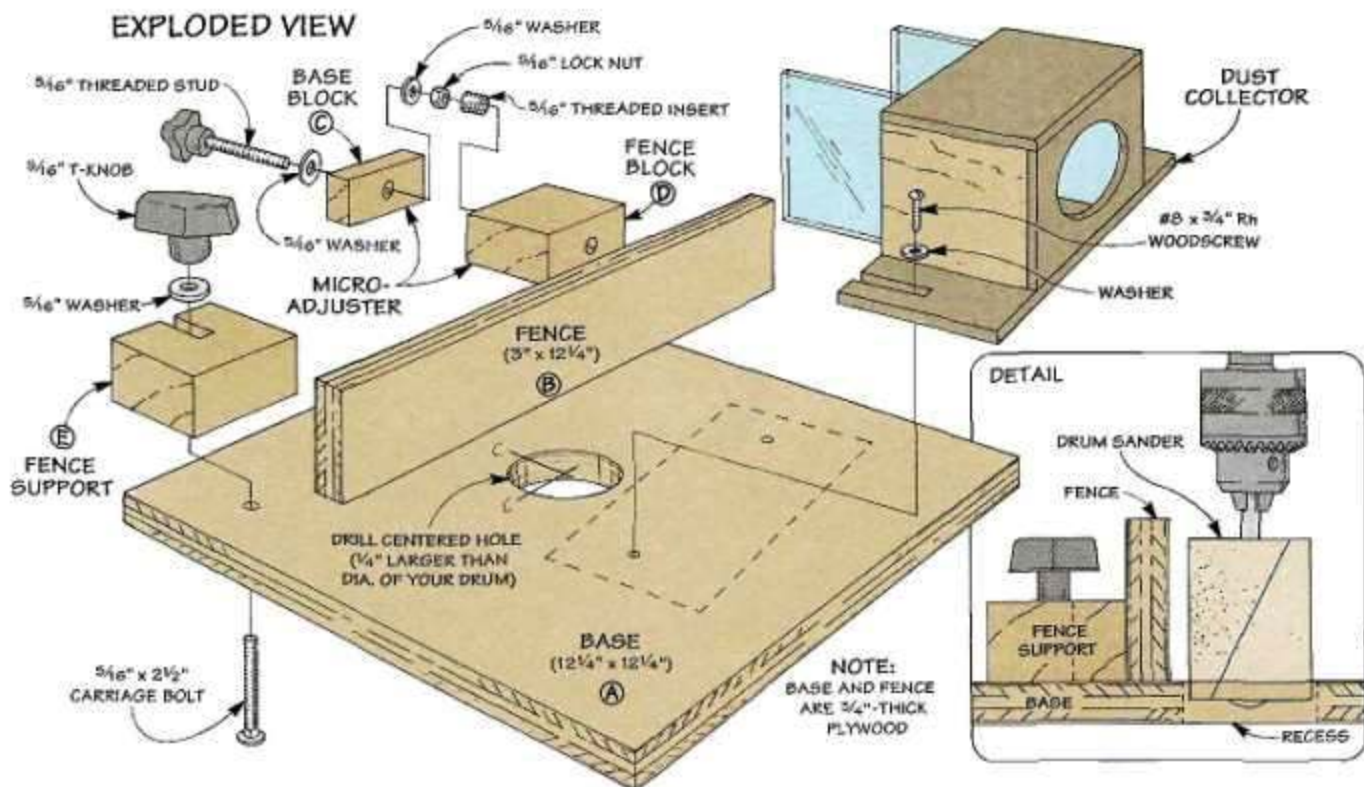



**FENCE.** To make the fence assembly, start by cutting a 3" tall fence (B) to match the width of the base (A), see Exploded View.

**MICRO-ADJUSTER.** Next, to "fine-tune" the space between the fence and the drum, I added a micro-adjuster behind the fence.

The micro-adjuster is made up of two blocks — a base block (C) and a fence block (D), see Fig. 1. A threaded stud passes through the base block (C) and is held in place with a lock nut. (For sources, see page 31.) Note: You could also use a 4" eye bolt in place of the threaded stud.

The stud screws into a threaded insert in the fence block (D). When you turn the knob, it moves the fence back and forth, see Cross Section in Fig. 1.

To make the micro-adjuster, first cut a blank to size, see Fig. 1a. For the threaded stud to line up in both blocks, drill the hole first, then cut the base block (C) off the fence block (D), see Fig. 1a.

Next, screw the base block to the base. Then slide the threaded stud through the hole and thread on the lock nut. Now, install the threaded insert into the fence block (D) and glue this block to the fence, see Fig. 1.

**FENCE SUPPORT.** To support the other end of the fence, I added a fence support (E), see Fig. 2. It's just a piece of 1½"-thick stock with a notch cut in it. The notch allows for rough positioning of the fence.

A carriage bolt and a T-knob hold this end of the fence in place. To locate the hole for this bolt, turn the micro-adjust knob until the fence block (D) pulls up tight against the lock nut, see Fig. 3.

Now locate and drill a counter-bored hole in the base for the bolt in the fence support block (E). Finally, push the bolt through the base and thread on a T-knob, see Fig. 2a. (I used a plastic knob, but a wing nut will work as well.)

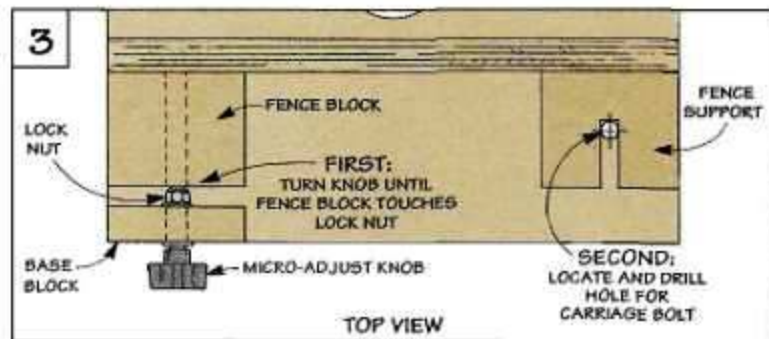
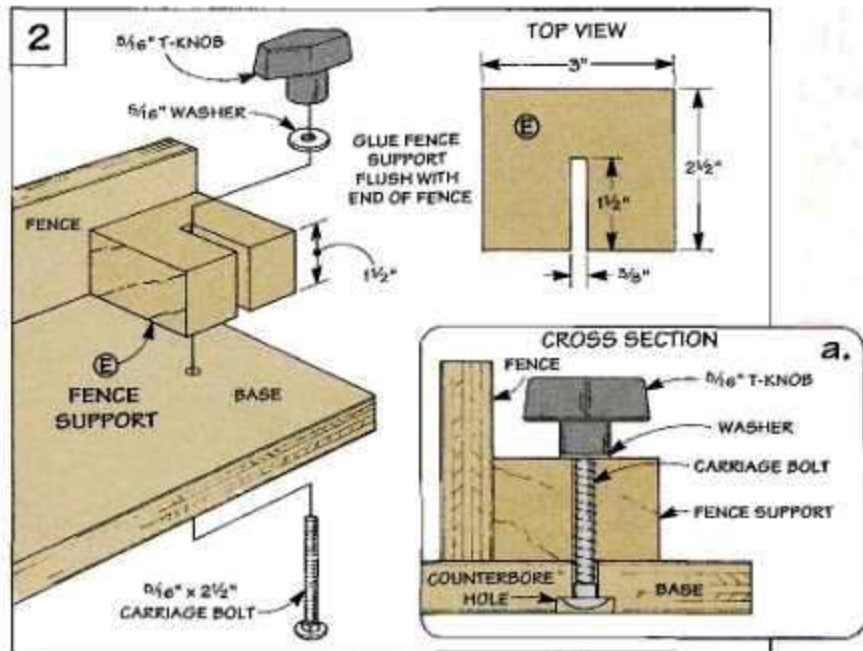
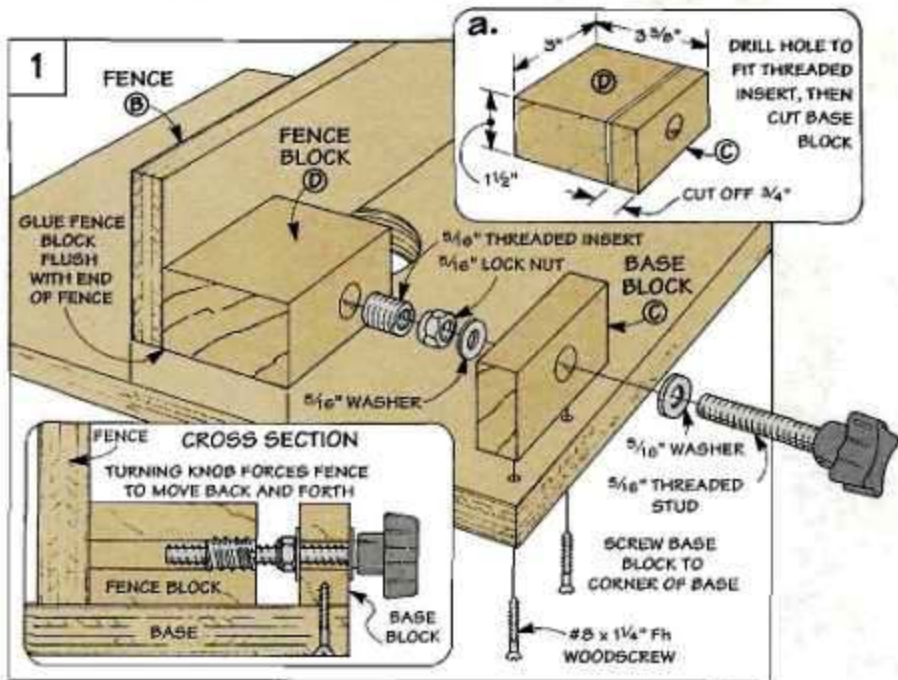

# Dust Collector

Once you've attached the fence assembly to the base, the next step is to add the dust collector.

The dust collector is basically a box with an open end that faces the drum sander. A hole in the back is sized to fit the hose on your shop vacuum, see Fig. 4.

The bottom of the box extends beyond the sides so slots can be cut in the bottom to allow the collector to be easily positioned or removed.

**EXTENSIONS.** To help concentrate the vacuum suction and allow a clear view of the workpiece, I added a pair of Plexiglas extensions, see Fig. 5.

These extensions also act as guards to keep your fingers away from the rotating drum.

**FEATHERBOARDS.** By making one extension longer than the other and mounting the collector at an angle, the extensions work like featherboards. This way they press the workpiece tight against the fence, refer to Fig. 4a.

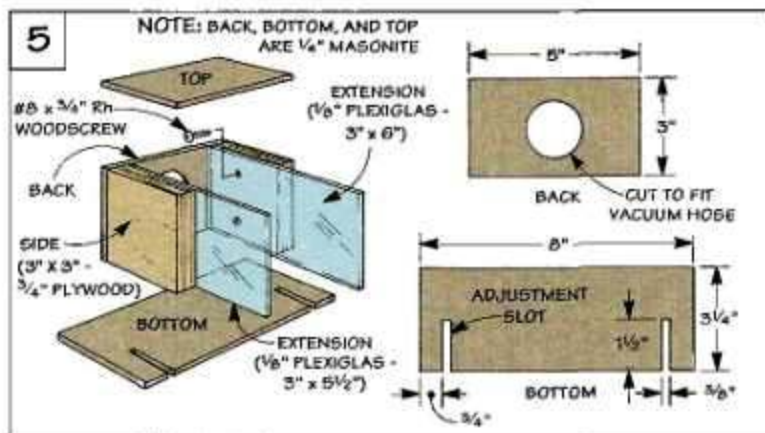
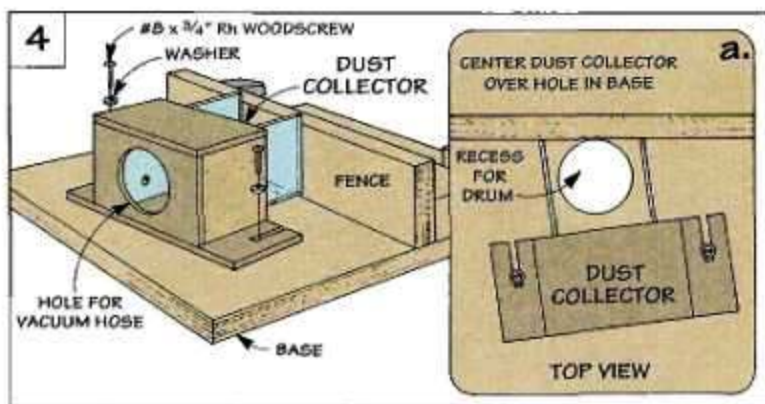

## Using the Thickness Sanding Jig

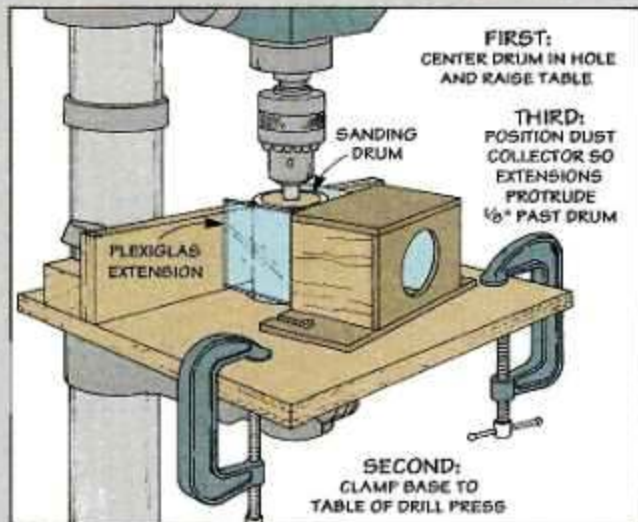

▲ **Step 1:** Start by centering the sanding drum over the hole in the base. Then raise the table and clamp the base to it. Next, position the dust collector on the base so the extensions protrude about 1/8" past the drum sander.

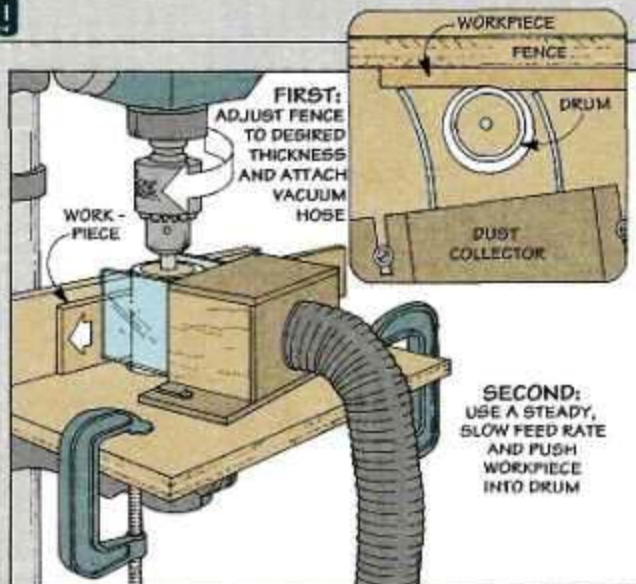

▲ **Step 2:** Now you can adjust the fence to the desired thickness by using the micro-adjuster. Attach the vacuum hose, and then feed the workpiece slowly into the drum. Use a constant, even feed rate.

# Shop-Made Drum Sander



Most drum sanders have a body made out of flexible rubber. When a sanding sleeve is slipped over the rubber body and the drum is tightened, the center of the drum bows out. As the workpiece is fed between the fence and the drum, this bow "dishes out" the workpiece.

To solve this problem, I use a shop-made drum sander. It's just a piece of PVC pipe with a strip of adhesive-backed sandpaper wrapped around it, see photo.

**THE SHAFT.** The shaft of the drum sander is a 6"-long,  $\frac{3}{8}$ " carriage bolt with the threads cut off, see Fig. 1.

**THE CORE.** For the core, I used five 2"-diameter flat toy wheels. These wheels fit perfectly inside 2" PVC and have a center hole that fits the shaft, see Fig. 1.

**THE PIPE.** The PVC pipe provides straight walls that won't bow out. Cut it to match the combined height of the wheels, see Fig. 1. Then epoxy the shaft in the core, and the core in the pipe, see Fig. 1.

**TRUE UP THE DRUM.** To true up the drum, first attach a strip of sandpaper to a piece of  $\frac{1}{4}$ " Masonite. Then adjust the fence on the sanding jig to  $\frac{1}{4}$ " and feed the Masonite (with sandpaper facing out) into the rotating drum, see Fig. 2. Repeat as necessary, adjusting the fence between passes until the drum is round.

**SANDING SLEEVE.** The sanding sleeve is just a piece of adhesive-backed sandpaper that's cut to match the height (width) of the drum, see Figs. 3 and 3a.

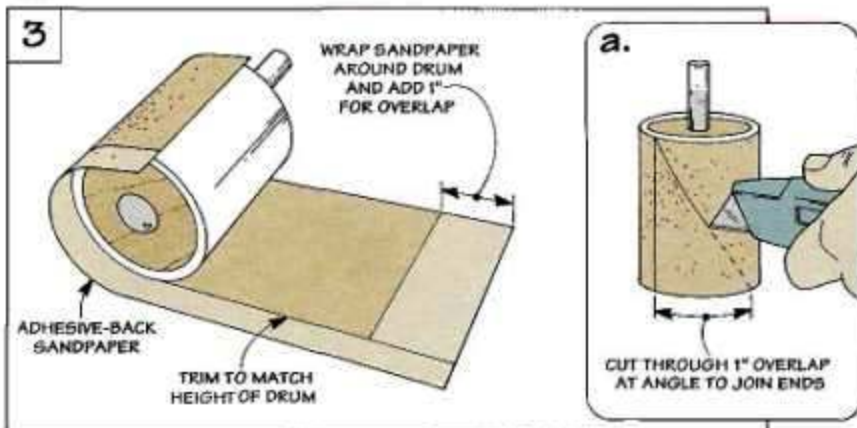
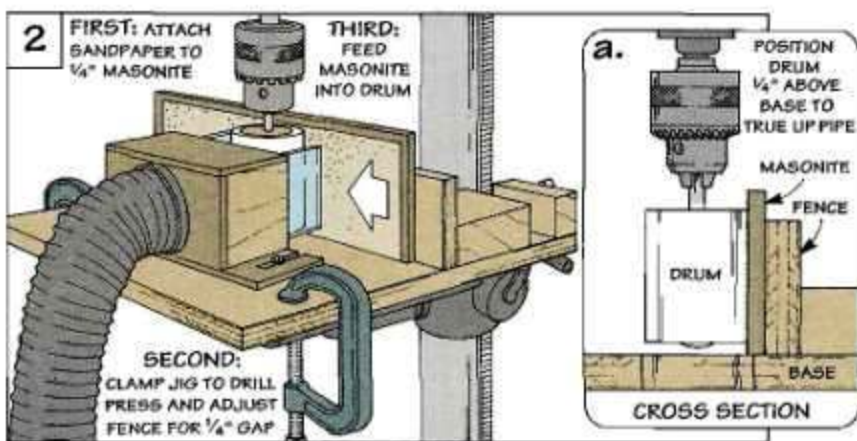
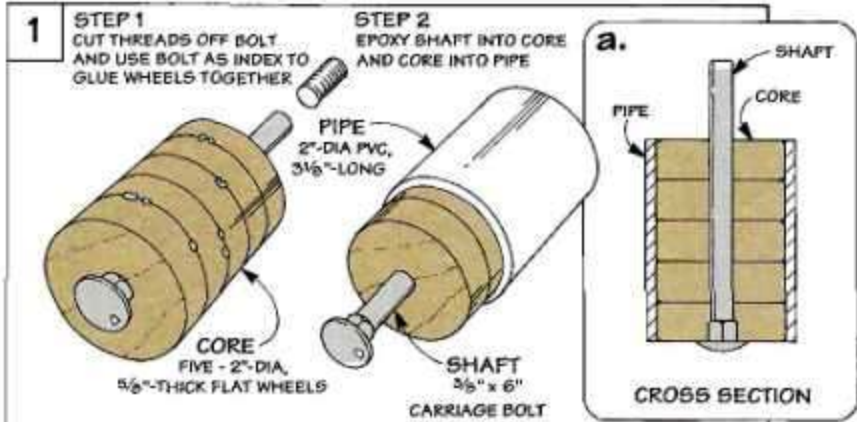

# Sharpening Hand Saws

*Sharpening a hand saw is easy. All it takes is a little practice and a few simple tools.*

**T**he only thing more frustrating than trying to cut with a dull hand saw is waiting the week or two it takes to get one sharpened. Many people think there's something mysterious about sharpening a saw. But that's not true. All you need are a few simple tools and a little practice.

**TOOLS.** The first thing you'll need to sharpen a hand saw is a vise to hold the saw steady (see page 18 to make your own).

Then you'll need a tool called a saw set to bend the tips of the teeth, see center photo below.

Finally, you'll need a triangular file to bring the teeth to a sharp point, see bottom right photo.

(See page 31 for sources of saw sharpening tools.)

## THREE STEPS

There are three basic steps to sharpening a crosscut saw: jointing, setting, and filing, see photos below.

**JOINTING.** To start, all the teeth on a saw should be the same height. If they're not, some teeth will stick out and end up doing most of the work. These teeth will dull and tear the fibers of the wood.

To prevent this, the saw is "jointed" with a file. Basically, you just knock off the points of the teeth so they're all the same height.



**SETTING.** After jointing a saw, the next step is to set the teeth. Setting the teeth widens the kerf the blade cuts. This prevents the blade from binding. To do this, a special tool called a *saw set* bends alternate teeth in opposite directions. Note: You don't need to set a saw every time you sharpen it. It only needs to be done about every third or fourth sharpening.

**FILING.** Filing sharpens the teeth and is the most important of the three steps. The teeth on crosscut saws are filed to fine points with a triangular file. This way the teeth cut like knives and sever the fibers of the wood as they cut across the grain.



▲ **Jointing:** To ensure all the teeth on a saw are at the same height, a file is run lightly across the tips of the teeth.



▲ **Setting:** Next, a tool called a *saw set* is used to bend the tips of the teeth. This keeps the blade from binding.

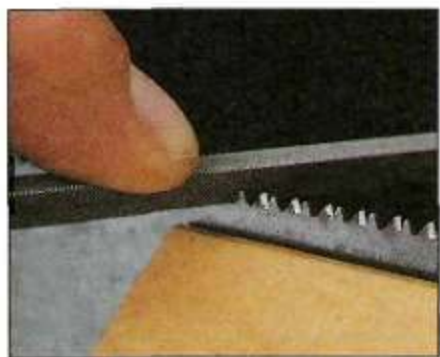

▲ **Filing:** A triangular file is then used to sharpen the teeth of the saw once they've been jointed and set.

## Jointing

The main reason for jointing a saw is to get all the teeth the same height. But there's also another reason.

The "flat" that's created from jointing is a great visual reference. When you sharpen the saw, these "flats" will disappear as the teeth are filed to a point.

**A VISE.** Jointing is simple. All it takes is a sharp mill file and a vise to hold the saw. If you don't have a saw vise, you can make one (see the box below), or just clamp the saw between a pair of wood jaws in your bench vise.

**FILE GENTLY.** To joint a saw, grasp the file with both hands so your thumbs are on top and parallel, see Fig. 1. Then, to keep the file perpendicular to the blade, press your knuckles against the sides of the saw blade. Now run the file *gently* across the teeth, see Fig. 1. Sometimes all you'll

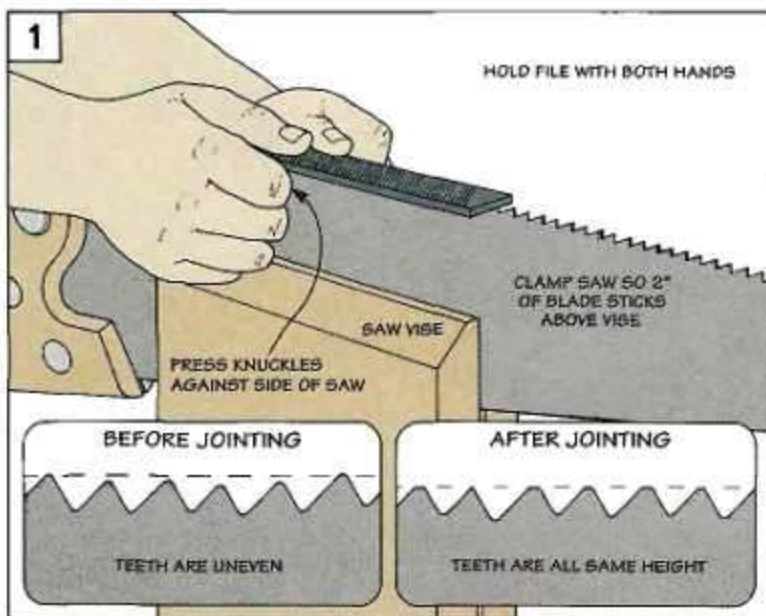

need to take is one pass.

Note: If the teeth are very uneven (or broken) and more than a light jointing is necessary, the

teeth may need to be reshaped or even recut. In this case, I'd suggest you take the saw to a shop and have this done professionally.

## Shop-Made Saw Vise

A traditional metal saw vise does two things. First, it clamps a large section of the saw blade to hold it steady. Second, it makes sharpening more comfortable by raising the saw up off the bench.

This shop-made vise does both. It's just a pair of hardwood jaws with a spline near the bottom. The spline acts like a hinge to keep the jaws parallel to each other, see drawing.

A carriage bolt and a wing nut provide the clamping pressure. The wide, shallow dado that's cut in the longer jaw helps concentrate the pressure at the top of the vise, see drawing.

To use the vise, first clamp it in your bench vise or screw it to the front edge of your bench. Then, loosen the wing nut, insert the blade between the jaws, and tighten the nut.

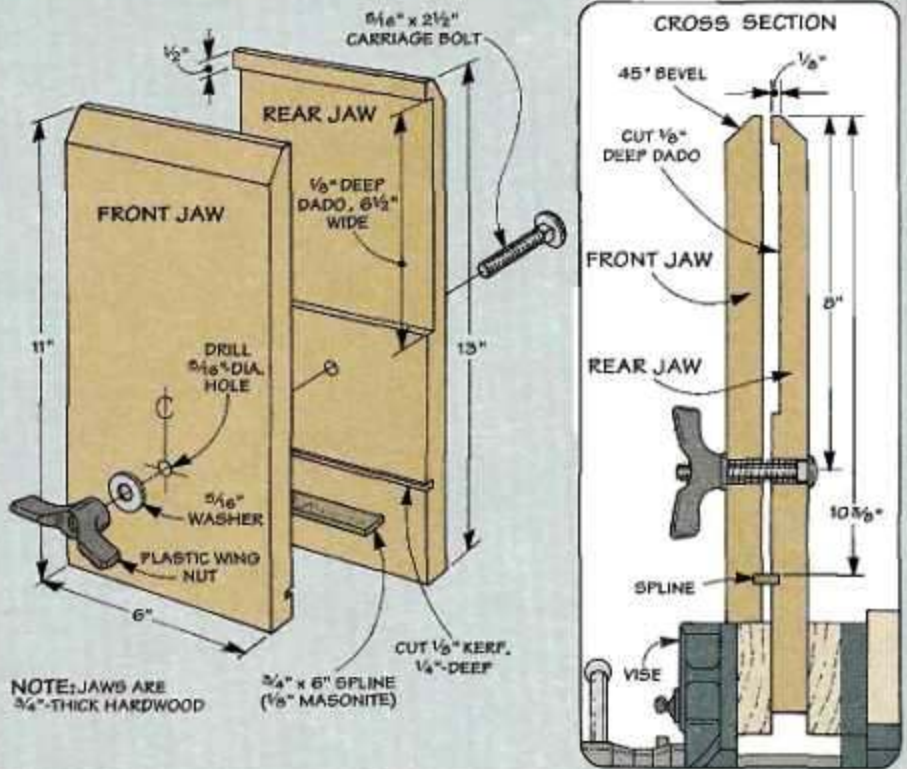

## Setting

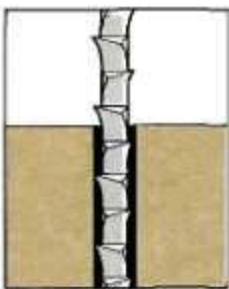

*Setting a saw bends the tips of the teeth alternately to the right and left to create a wider kerf.*

After the saw is jointed, the next step is to "set" the teeth. Setting bends the tips of the teeth alternately to the right and to the left, see drawing at left. This way they cut a kerf wider than the blade—which reduces friction and the chance the blade will bind.

The goal is to set the teeth so the kerf doesn't pinch the blade (not enough set) or allow it to wobble (too much set).

**SAW SET.** Setting a saw requires a special tool called a *saw set*, see Fig. 2. (For sources, see page 31.) Squeezing the handle of the set pushes a hammer against the saw tooth and bends the tip over an anvil, see Fig. 2a.

How much set you'll need depends on the number of teeth per inch on your saw. This is where things can get a little confusing.

**TEETH PER INCH.** To determine the number of teeth per inch, first lay the edge of a ruler flush with the bottom of the gullets (the space between the teeth), see Fig. 3.

Then align the ruler with a gullet and count the number of teeth in one inch. (Most crosscut saws have 8 to 10 teeth per inch.)

**SETTING A SAW.** To set the saw, first adjust the anvil on the saw set to match the number of teeth per inch on your saw, see Fig. 2a.

Then clamp the saw in a saw vise, see Fig. 4. Start at one end of the saw and set the first tooth that bends away from you. Just center the hammer on the tooth and squeeze the handle, taking a full stroke, see Fig. 4a.

Now skip a tooth and set the next one. Continue like this, skipping every other tooth. When you reach the end of the saw, turn it around in the vise and set the other side, skipping every other tooth.

Note: You don't need to set your saw each time you sharpen it—every third or fourth filing will provide plenty of set.

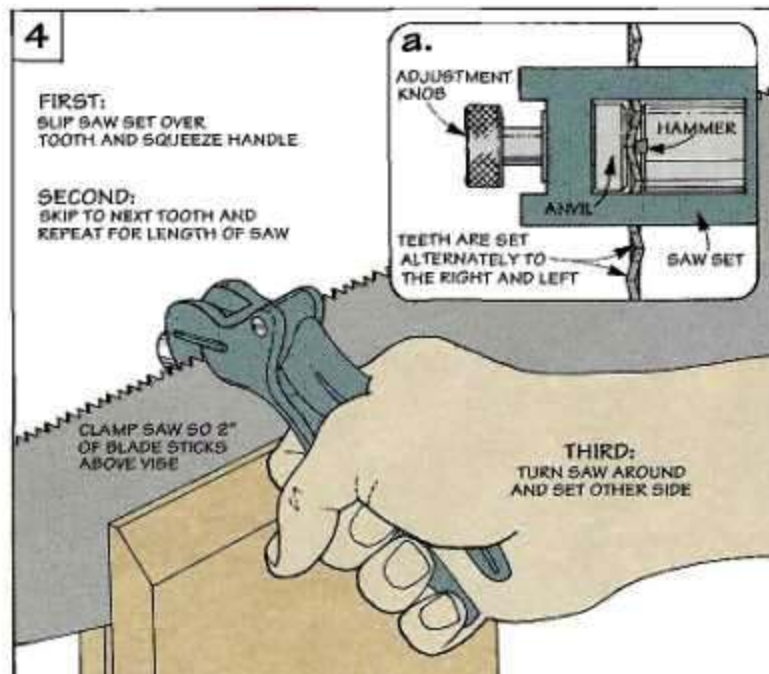
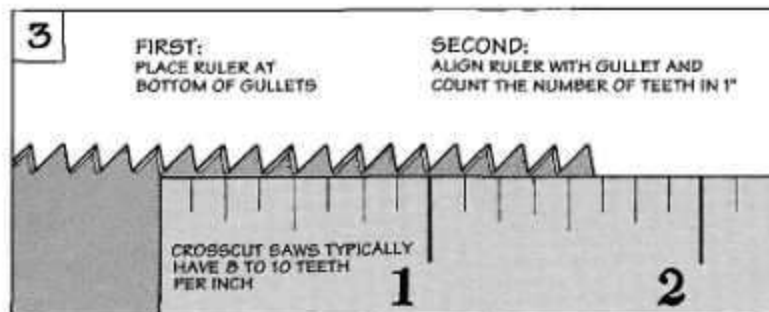
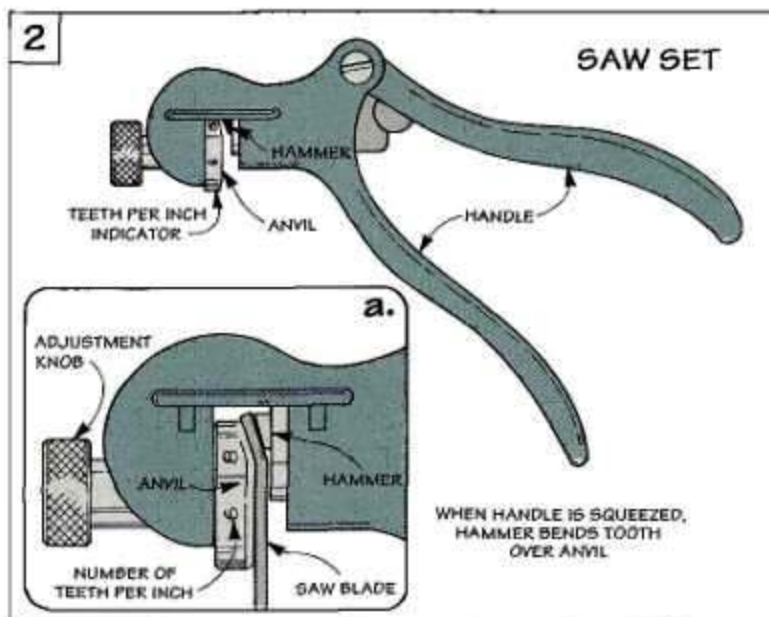

## Filing

After a saw is set, the only thing left to do is sharpen the teeth with a file. Filing the teeth of a saw is easy if you remember two things. First, let the saw teeth guide your file. And second, let the file do the work.

To start, clamp your saw in a vise so the bottom of the gullets are about  $\frac{1}{8}$ " above the vise. This prevents the saw blade from vibrating or chattering.

**THE FILE.** I use a 6" triangular smooth mill file for sharpening. To find the filing angle, just seat the file in a gullet and press down gently, see Step 1. The teeth will guide the file to the correct angle.

The corner of the file should sit in the gullet at a slight angle (about  $15^\circ$ ), see Step 1. And the sides of the file will rest against the bevel that's ground on the teeth (around  $65^\circ$ ), see Step 1.

**FILING.** Once you've found the angle, let the teeth guide the file as you push it forward, see Step 2. Use a light touch and let the file do the work. The file will sharpen the back of one tooth and the front of the next tooth at the same time.

Take three strokes. Then skip a tooth, and take the same number of strokes, see Step 2. Repeat this for the entire length of the saw, skipping every other tooth.

When you reach the end, turn the saw around and work from the other side, see Step 3. This step should bring the teeth to a fine point.

**IS IT SHARP?** Sight down the blade. If any of the tips of the teeth reflect light, you'll need to file them to a point.

When the saw is sharp, the teeth will feel "sticky" when touched with your fingers (because of the burr that's left from filing). But the real test is how it cuts. Grab a piece of scrap wood and give it a try — you'll be surprised at how effortlessly it cuts.

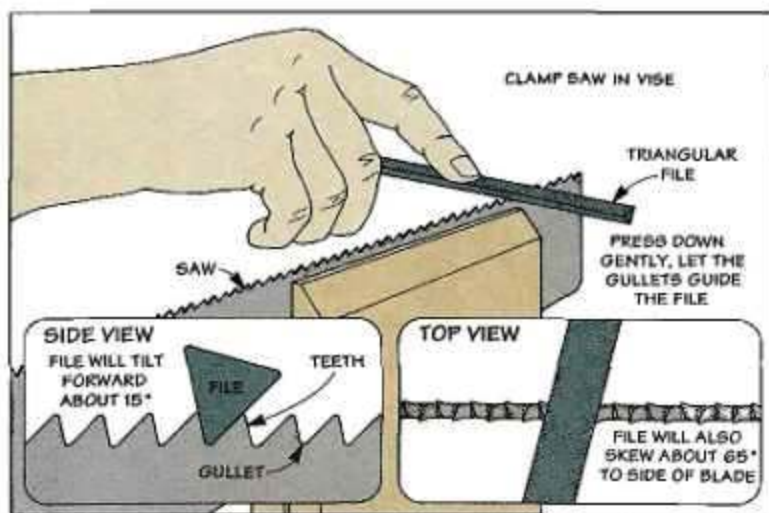

**▲ Step 1:** Let the gullet guide the file as you gently push it straight down. As it seats itself between the teeth, it'll tilt forward about  $15^\circ$  and skew at a slight angle to the side of the blade.

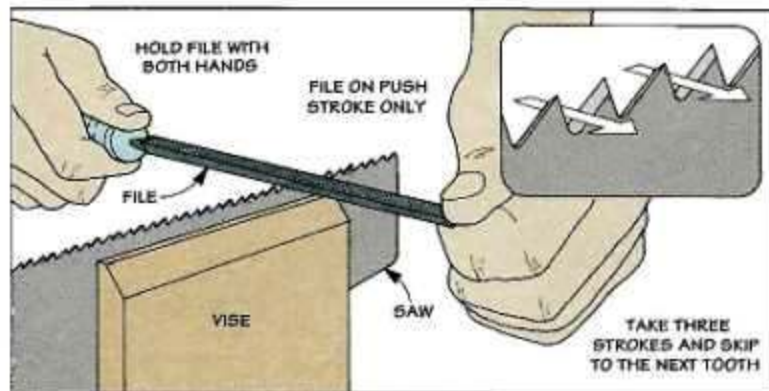

**▲ Step 2:** Now file three smooth strokes, lifting the file between each stroke. Skip every other tooth as you file. And make sure to keep the angle and number of strokes the same.

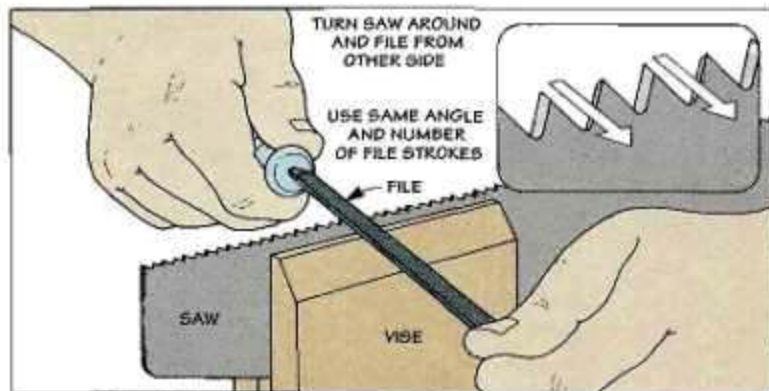

**▲ Step 3:** When you reach the end of the saw, turn the saw around and work from the opposite end. Once again, use the same filing angle and take the same number of strokes.

Triangular files come in a variety of cuts and lengths. I use a smooth cut 6"-long mill file to sharpen hand saws.

# Panel Saw

*This shop-built panel saw allows precision crosscutting and ripping of large sheet goods. And it costs only a fraction of professional saws.*



I've always been impressed with panel saws. They make it easy for one person to accurately cut a full sheet of plywood into manageable pieces.

The basic principle of these saws is simple. A sheet of plywood slides in and rests against a vertical bed. Then a circular saw is pulled down a couple of guide rails to cut the sheet.

The only drawback is the cost — over \$1000 for a full-sized model. So I decided to build a shop-made version with all the features I liked, see photo.

**VERTICAL BED.** First of all, there's a large A-shaped vertical bed to support a full sheet of plywood. The trick is to make sure the bed won't twist

or warp after it's assembled. So I made the bed out of  $\frac{3}{4}$ " birch plywood. And for the rails that support it, I chose Douglas Fir for its strength and straight grain.

**CARRIAGE ASSEMBLY.** Another feature of the panel saw is the carriage assembly. This assembly provides a way to slide the saw smoothly on a pair of guide tubes. Note: This panel saw requires a circular saw with a  $7\frac{1}{4}$ " diameter blade.

**RIPPING.** The panel saw can also be used for ripping. Just lock the carriage in place, rotate the saw 90°, and push the *workpiece* through the blade. To provide additional support when ripping a full sheet of plywood, I added two removable "wings" to the sides of the saw.

**MOBILE.** Since the panel saw is about 10-feet long (with the wings in place), I attached casters to roll it around to wherever I need it. When I'm done cutting, the panel saw folds up flat and rolls against the wall for storage.

**HARDWARE.** To build the panel saw, you'll need quite a bit of hardware, see Hardware List below. But don't let that scare you. I found all the parts I needed at the local hardware store. (There's also a source of hardware on page 31.)

## Hardware List

#8 x $1\frac{1}{4}$ " Fh Woodscrews (21)	$\frac{1}{4}$ " Washers (18)	$\frac{5}{16}$ " Plastic T-Knobs (3)
#8 x $1\frac{1}{2}$ " Fh Woodscrews (94)	$\frac{1}{4}$ " Hex Nuts (3)	$\frac{1}{4}$ " x $1\frac{1}{4}$ " Fender Washers (4)
$\frac{1}{4}$ " x $1\frac{1}{2}$ " Lag Bolts (8)	$\frac{5}{16}$ " Hex Nuts (18)	$\frac{1}{4}$ " T-Nuts w/Brad Holes (7)
$\frac{3}{8}$ " x 5" Lag Bolts (8)	$\frac{7}{8}$ " Nail-On Plastic Glides (5)	$\frac{5}{16}$ " T-Nuts (4)
$\frac{3}{8}$ " Washers (8)	$\frac{5}{16}$ " x $1\frac{1}{2}$ " Eye Bolt (1)	2" Swivel Casters (2)
3" Butt Hinges w/Screws (8)	$\frac{5}{16}$ " x 2" x $3\frac{1}{4}$ " U-Bolts (4)	#6 x $1\frac{1}{2}$ " S-Hook (1)
$1\frac{1}{2}$ " Conduit Straps (4)	$\frac{5}{16}$ " x 2" x $3\frac{1}{4}$ " Square U-Bolt (1)	$\frac{3}{32}$ " Wire Rope (7 ft.)
$\frac{5}{16}$ " x 3" Hanger Bolts (2)	$\frac{5}{16}$ " Lock Nut w/Nylon Insert (1)	$\frac{3}{32}$ " Crimp-On Clips (2)
$\frac{5}{16}$ " Washers (14)	$1\frac{1}{2}$ " Nylon Spacers - .375 x .562 (34)	$\frac{1}{4}$ " x 4" Hex Bolt (1)
$1\frac{1}{2}$ " Sliding Glass Door Wheels (2)	$\frac{1}{4}$ " x $\frac{3}{4}$ " Threaded Round Knobs (7)	3" x 13" PVC Pipe (1)
$\frac{1}{4}$ " x $1\frac{1}{2}$ " Hex Bolts (2)	$\frac{5}{16}$ " x $2\frac{1}{4}$ " Threaded Star Knobs (4)	Weight (see page 23)



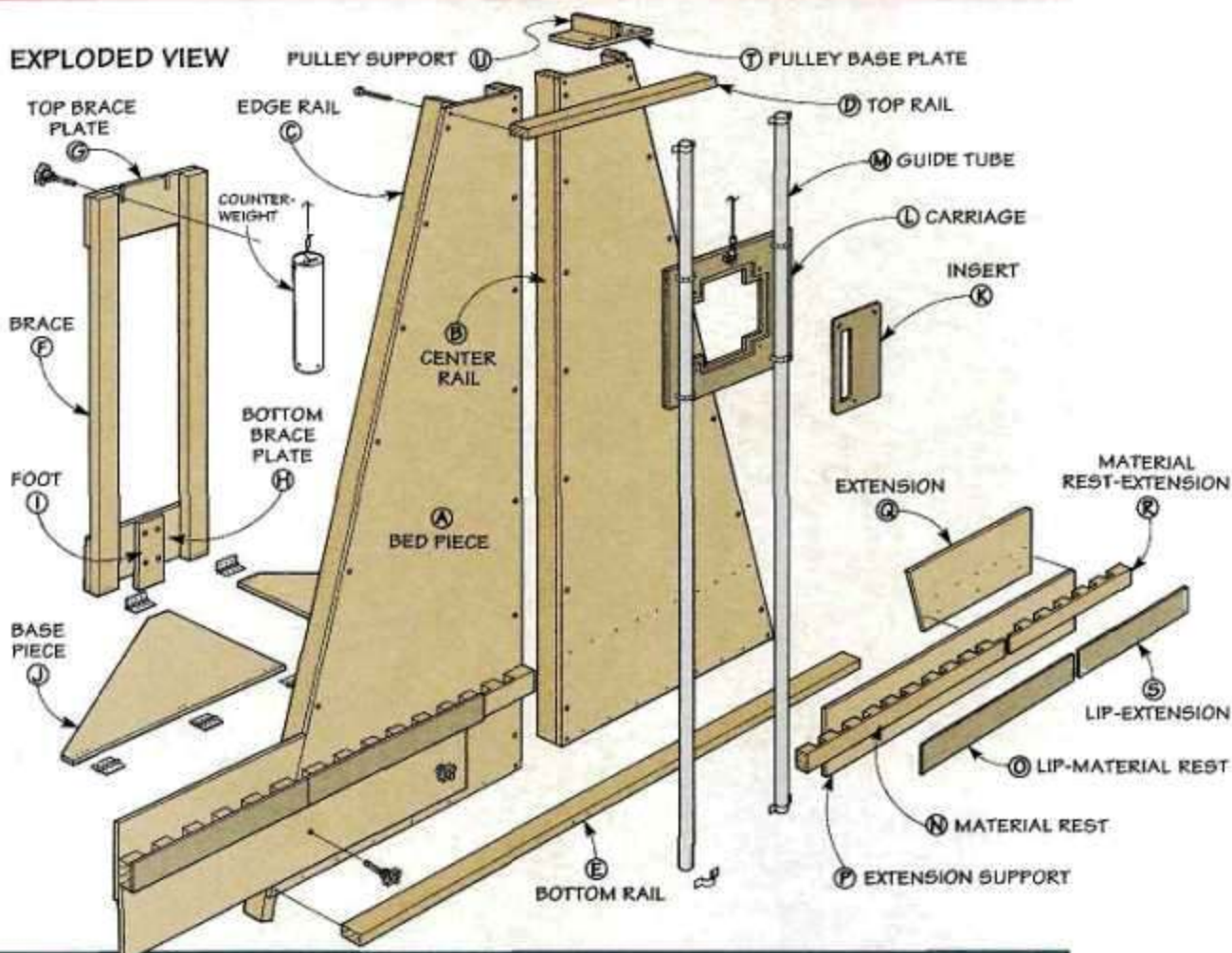

## Materials List

### Bed

A Bed Pieces (2)	11 <sup>7</sup> / <sub>8</sub> x 36 - 72 - 3/4 Ply
B Center Rails (2)	1 <sup>1</sup> / <sub>2</sub> x 3 - 72
C Edge Rails (2)	1 <sup>1</sup> / <sub>2</sub> x 3 - 78
D Top Rail (1)	1 <sup>1</sup> / <sub>2</sub> x 2 <sup>3</sup> / <sub>8</sub> - 30 <sup>5</sup> / <sub>8</sub>
E Bottom Rail (1)	1 <sup>1</sup> / <sub>2</sub> x 2 <sup>3</sup> / <sub>8</sub> - 77 <sup>1</sup> / <sub>8</sub>

### Back Support

F Braces (2)	1 <sup>1</sup> / <sub>2</sub> x 3 - 48
G Top Brace Plate (1)	6 x 15 <sup>1</sup> / <sub>2</sub> - 3/4 Ply
H Bottom Br. Plt. (1)	6 x 15 <sup>1</sup> / <sub>2</sub> - 3/4 Ply
I Foot (1)	3 x 8 - 3/4 Ply
J Base Pieces (2)	19 <sup>3</sup> / <sub>4</sub> x 32 rgh. - 3/4 Ply

### Carriage Assembly

K Insert (1)	7 <sup>3</sup> / <sub>4</sub> x 11 <sup>3</sup> / <sub>4</sub> - 1/4 Masonite
L Carriage (2 pieces)	15 <sup>3</sup> / <sub>4</sub> x 19 - 1/4 Masonite
M Guide Tubes (2)	1 <sup>1</sup> / <sub>2</sub> EMT conduit - 72

### Material Rest and Wings

N Material Rest (2)	1 <sup>1</sup> / <sub>4</sub> x 2 - 33 <sup>3</sup> / <sub>4</sub>
O Lips-Mat'l Rest (2)	2 <sup>1</sup> / <sub>2</sub> x 25 <sup>3</sup> / <sub>4</sub> - 1/4 Masonite
P Ext. Supports (2)	7 x 48 - 3/4 Ply
Q Extensions (2)	7 <sup>1</sup> / <sub>8</sub> x 24 - 3/4 Ply

R Mat'l. Rest-Ext. (2)	1 <sup>1</sup> / <sub>4</sub> x 2 - 22
S Lips-Extensions (2)	2 <sup>1</sup> / <sub>2</sub> x 22 - 1/4 Masonite

### Pulley System

T Pulley Base Plate (1)	6 x 9 - 3/4 Ply
U Pulley Support (1)	2 x 6 - 3/4 Ply

## Cutting Diagram

3/4 x 48 - 96 BIRCH PLYWOOD

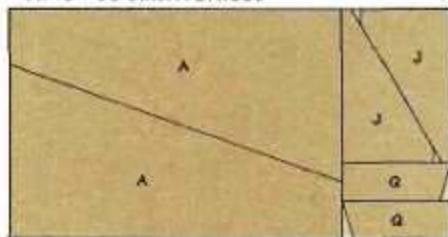

3/4 x 24 - 48 BIRCH PLY.

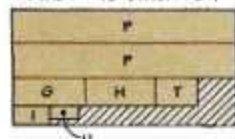

1/4 x 24 - 48 TEMPERED MASONITE

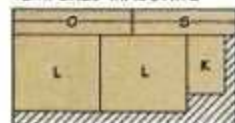

NOTE:  
ALSO NEED FOUR  
8-FOOT 2x8's

# Bed

I started work on the panel saw by making the bed. The bed is built in two sections. Each section consists of a triangular piece of plywood with two support rails screwed to the long edges, refer to Fig. 2.

**CUT PIECES.** To make the bed sections, start by cutting two *bed pieces* (A) from a blank of  $\frac{3}{4}$ " plywood, see Fig. 1.

Next, cut the *center* and *edge rails* (B, C) to length, see Fig. 2. Note: The edge rails are cut 6" longer than the center rails. I used straight-grained  $1\frac{1}{2}$ "-thick stock for the rails and ripped them to a finished width of 3".

**ATTACH RAILS.** Now the rails can be clamped and screwed to the bed pieces. The edge rails (C) extend past the bottom edge of the bed and act as two of the "feet" for the panel saw, see Fig. 2b. To ensure the feet extend an equal distance, position the top inside corner of each edge rail flush with the top of the bed, see Fig. 2a.

**CONNECT SECTIONS.** After the two sections are complete, they're connected with a *top* and *bottom rail* (D, E), see Fig. 3. Here again I used  $1\frac{1}{2}$ " thick stock to make the rails, but this time the rails are ripped to a finished width of  $2\frac{3}{8}$ ".

**CUTTING TROUGH.** To prevent the saw from cutting into the bed, a space (cutting trough) is left between the two sections, see Fig. 3. I used a 6"-long scrap 2x4 as a spacer to position the bed sections on the rails, see Fig. 3. Note: This spacer will be used later to position the guide tubes.

For added strength, I lag bolted the ends of the edge and center rails to the top and bottom rails, see Fig. 3a.

**CASTERS.** Finally, to roll the saw around the shop, I screwed a pair of 2" swivel casters under the bottom rail, see Fig. 3b.

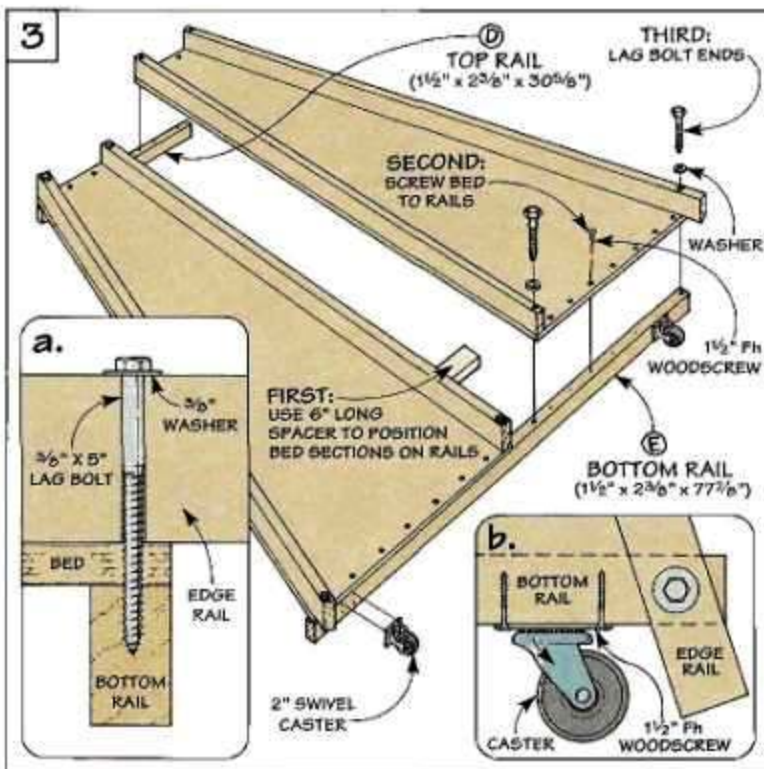
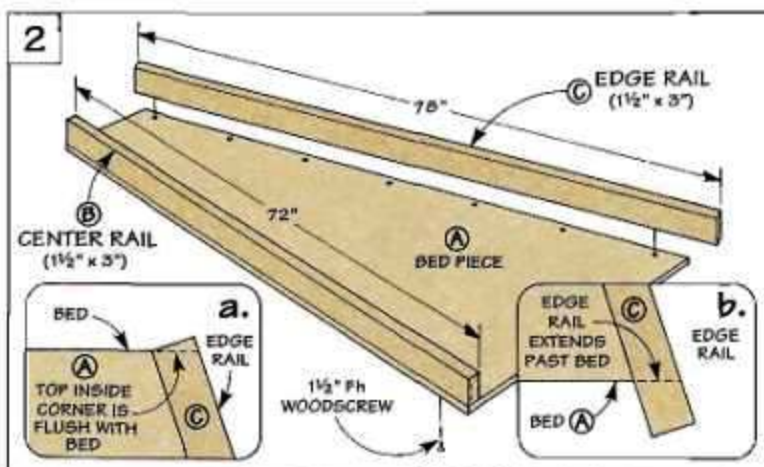
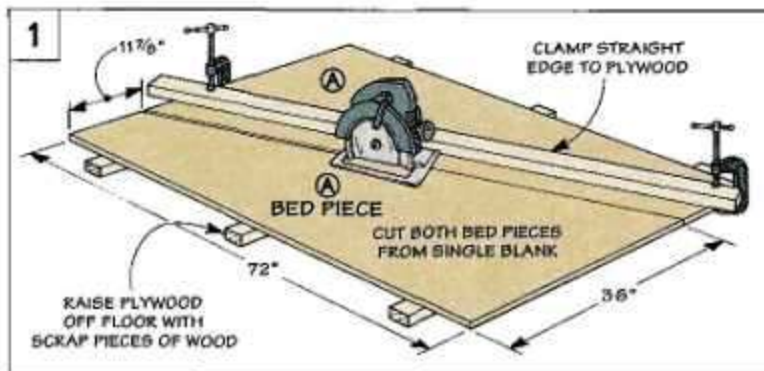

# Back Support

Once the bed is complete, the next step is to make the folding back support. In the "down" position, it holds the bed upright. To move the panel saw, the back support folds up, and the saw can be rolled around on the casters.

The back support consists of two main parts: a brace assembly and two base pieces, see Fig. 4.

**BRACE ASSEMBLY.** The brace assembly is just a simple wood frame, see Fig. 5. The braces (F) are 1½" thick stock cut to a finished length of 48". The frame is completed by screwing a ¾" plywood top and bottom plate (G, H) to the braces, see Fig. 5.

To secure the brace assembly to the vertical bed, cut slots in the top plate, see Fig. 5. The slots fit over hanger bolts installed in the center rails, see Fig. 4a.

Tightening a plastic knob (or wing nut) on the end of each bolt locks the bed in place. Note: A counterbore at the end of the slots prevents the knob from sliding as it's tightened, see Fig. 5a.

**FOOT.** To complete the assembly, screw a plywood foot (I) to the bottom plate, see Fig. 5. With the ends of the two edge rails, this foot creates a "tripod" that stabilizes the panel saw, see Fig. 4b.

**BASE.** The last step is to build the base. The base is just two triangular-shaped pieces of plywood that keep the panel saw

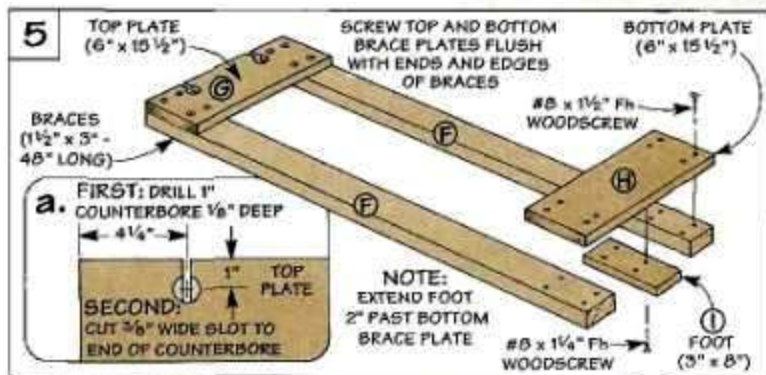
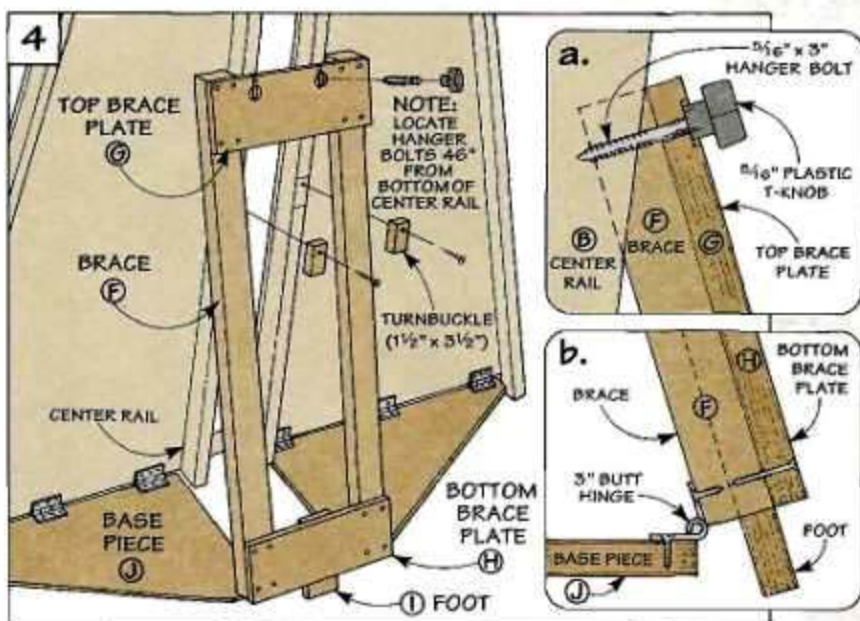

from racking, see Fig. 6.

The base pieces (J) are hinged to the bed and braces, see Fig. 6. To allow the back support to fold up, I left ¼" clearance between

the base pieces and the center rails.

**TURNBUCKLES.** Finally, screw a turnbuckle to each center rail to secure the back support in the "up" position, see Fig. 4.

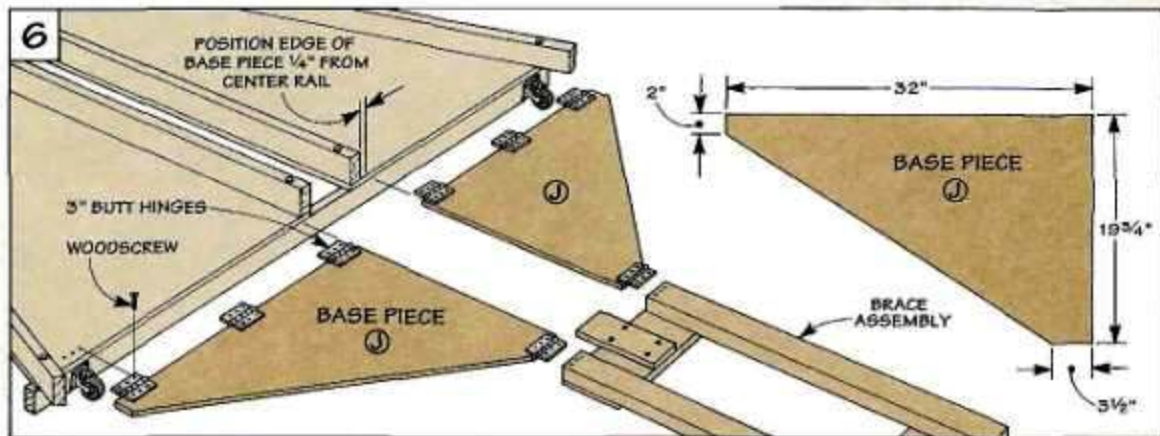

# Carriage Assembly

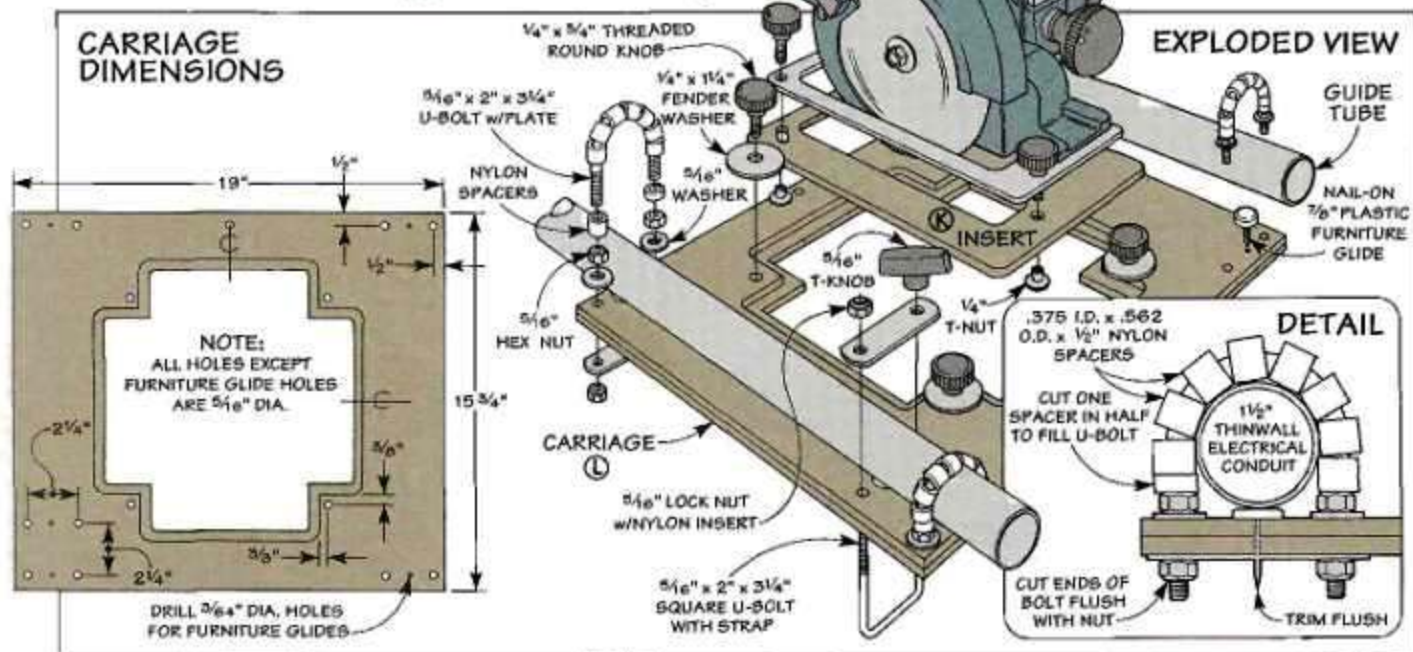

The heart of the panel saw is the carriage assembly. This assembly provides a way to mount the saw for accurate crosscutting or ripping. It consists of three main parts: an insert, a sliding carriage, and a pair of metal tubes.

## INSERT

The base of the saw is attached to an *insert* (K) made of  $\frac{1}{4}$ " Masonite that fits into a recessed opening in the carriage, see Exploded View above.

**MOUNTING HOLES.** The saw is mounted to the insert with  $\frac{1}{4}$ " threaded knobs and T-nuts. This requires drilling three holes in the base of your saw, see Fig. 7.

After drilling the holes, center the saw base on the insert, and transfer the location of the holes and the blade opening onto the insert. Now you can drill the holes and cut the slot in the insert.

**ADJUSTMENT.** Next, to provide a way to adjust the saw, enlarge the two holes at the end of the insert, see Fig. 7a. The single hole at the end of the insert will be used later as a "pivot point" to help position the blade.

## CARRIAGE

Like its name implies, the carriage "carries" the saw up and down the guide tubes. Depending on whether you're ripping or

crosscutting, the insert fits into one of the two recessed openings in the carriage. To make the *carriage* (L), start by gluing together two pieces of  $\frac{1}{4}$ " Masonite, see Fig. 8.

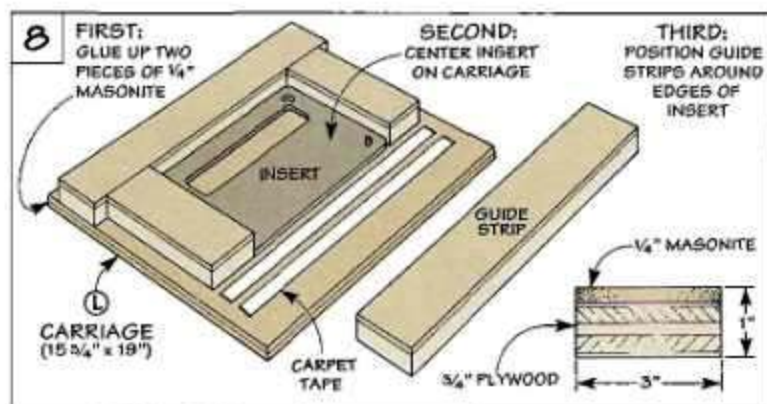
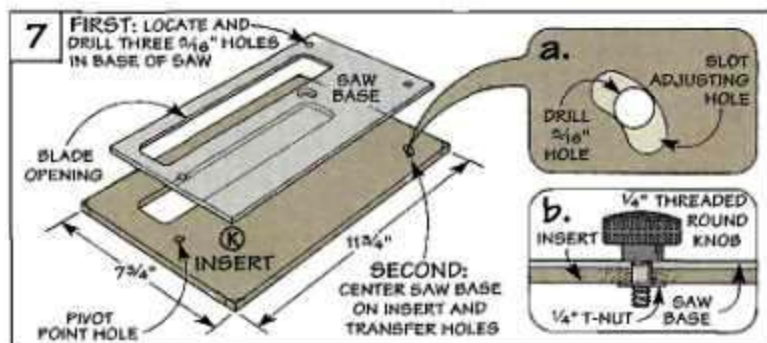

Creating the recessed openings is a simple two-step process. First, a 1/4" deep recess is routed to match the shape of the insert. Then a lip is created by removing the waste with a sabre saw.

The trick to making the recess is to use the insert as a template and rout the recess with a pattern bit. (For more on this, see page 4.) First, center the insert on the carriage, see Fig. 8. Then, to guide the router, tape strips around the edges of the insert with carpet tape.

**ROUT RECESS.** Now you can remove the insert and rout one recess, see Fig. 9a. Then repeat the process, and rout a second recess 90° to the first, see Fig. 9.

**LIP.** To complete the openings and form the lip, remove the waste with a sabre saw, see Fig. 9b.

**HARDWARE.** All that's left is to drill holes and install hardware on the carriage. To make the carriage slide smoothly without a lot of "play," I slipped nylon spacers over four U-bolts like beads on a necklace, see Detail in Exploded View.

And to reduce the friction between the guide tubes and the carriage, I added furniture glides between the ends of each U-bolt.

**GUIDE TUBES**

The next step is to attach the carriage guide tubes (M) to the top and bottom rails. These tubes are just 6-foot long pieces of 1 1/2" "thinwall" electrical conduit.

**MOUNT CARRIAGE.** Before attaching the guide tubes, slide the ends of the tubes through the carriage U-bolts. Now the carriage assembly can be located on the top and bottom rails.

The key is to center the carriage on the cutting trough and position the guide tubes parallel with each other. An easy way to do this is to use the same spacer that was used earlier to form the cutting trough. Just clamp the spacer so it's centered on the back

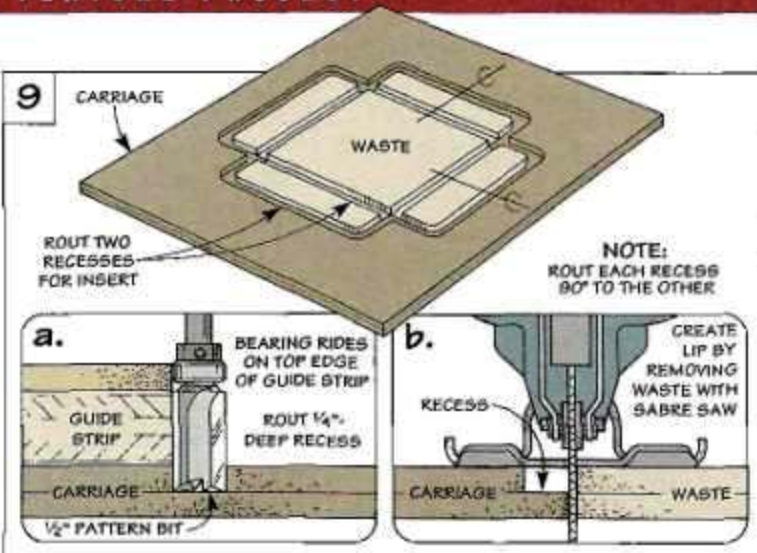

Enlarge the holes in the "ears" of the conduit straps to make the guide tubes adjustable.

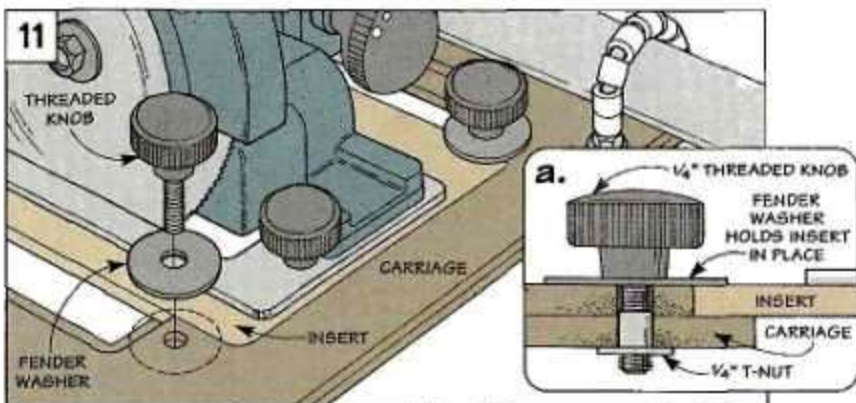
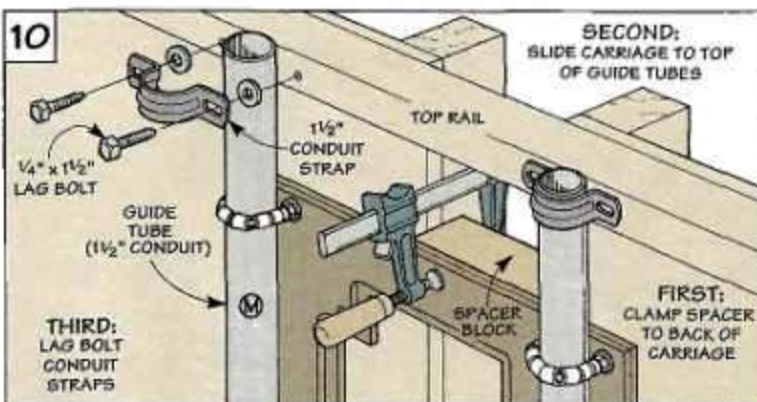

of the carriage and extends into the cutting trough, see Fig. 10.

As you slide the carriage to the top and bottom of the tubes, the spacer centers the carriage on the cutting trough, and positions the tubes parallel with each other.

**INSTALL TUBES.** Now the top and bottom ends of the guide tubes can be secured with conduit

straps and lag bolts, see Fig. 10. But first, to make the tubes adjustable, slot the holes in the "ears" of the conduit straps.

**ATTACH INSERT.** Finally, the insert can be attached to the carriage with threaded knobs and T-nuts, see Fig. 11a. The knobs tighten against fender washers which hold the insert in place.



# Pulleys and Counterweight

All that's left to complete the panel saw is to add a pulley system and counterweight, see photo. The idea here is for the saw carriage to return easily to the top of the guide tubes when you finish a cut.

## PULLEY SYSTEM

The pulley system consists of three parts: a *pulley base plate* (T), *pulley support* (U), and a couple of 1½" wheels used for sliding glass doors, see Fig. 14.

The base plate and the pulley support are both made from ¾" plywood, see Fig. 14. After drilling holes and bolting the wheels to the pulley support, the two pieces can be screwed together to form a T-shape, see Fig. 14a. Note: Locate the pulley support so the *pulleys* are centered on the length of the base plate.

To complete the system, the base plate is screwed to the top rail so the pulleys are centered on the width of the cutting trough.

## COUNTERWEIGHT

Now that the pulley system is in place, the last step is to add a counterweight. The secret is to make the counterweight roughly equal to the combined weight of your circular saw and carriage.

(In my case, this was 16 pounds.) This lets you pull the saw down the guide tubes without exerting a lot of pressure. And it allows the saw to travel easily back to the top of the tubes.

**LEAD SHOT.** To make the counterweight, I filled a length of 3" PVC pipe with lead shot, refer to Fig. 16. But sand, concrete, or any other weight would work as well, just as long as it clears the back support. To hold the shot, I cut a scrap piece of wood to fit inside the pipe, see Fig. 16b.

**WIRE CABLE.** After settling on a counterweight, I ran a 7-foot length of wire cable over the pul-

leys to connect the pipe to the carriage. Each end of the cable has a loop made with a crimp-on clip.

An S-hook in one loop hooks into an eye bolt installed on the carriage, see Fig. 15. The other end slips over a bolt which passes through the top of the pipe, see Fig. 16a. Note: To keep the loop from slipping to one side, file a notch in the middle of the bolt.

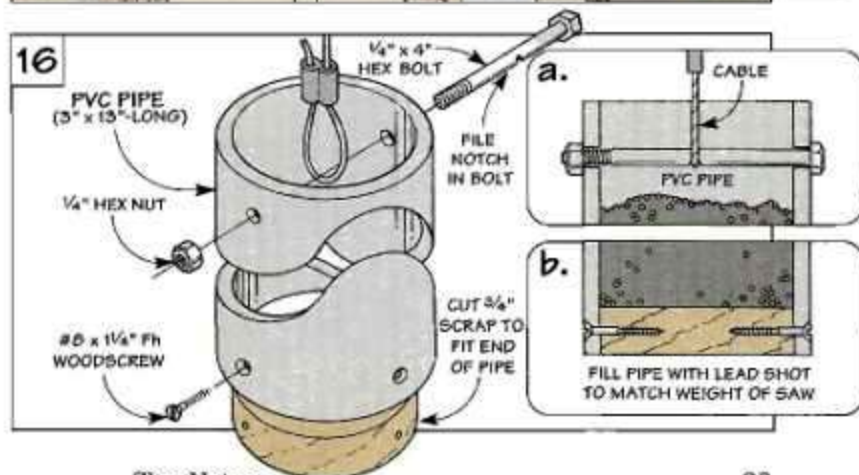
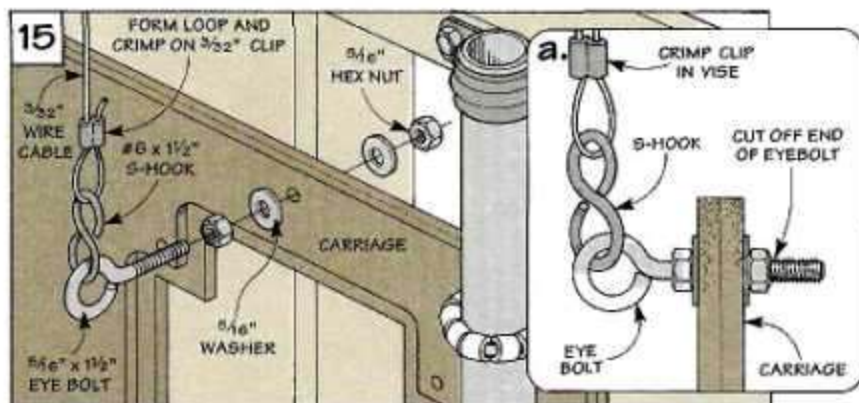
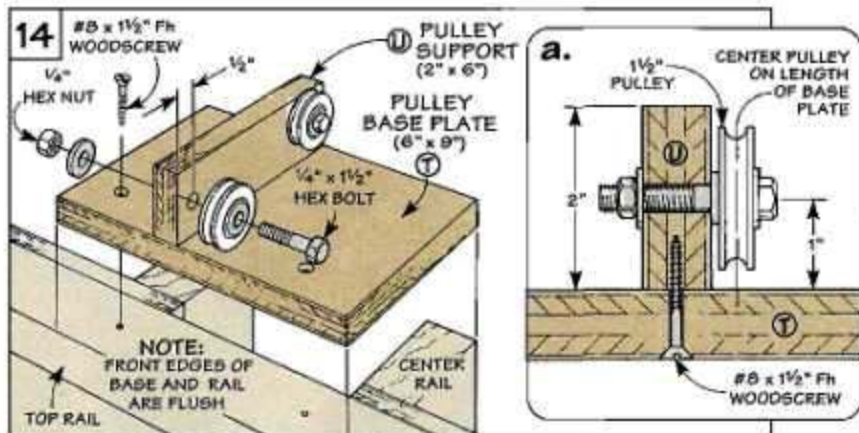

# Panel Saw Tune-up

■ To make perfect cuts with the panel saw, you need to take a few minutes to tune it up. The idea is to adjust the guide tubes so they're 90° to the material rest, see Steps 1 and 2. Then adjust the saw blade so it's cutting straight, see Steps 3 and 4.

To make these adjustments, place a sheet of plywood (with a "factory" square corner) on the material rest so one edge extends into the cutting trough.

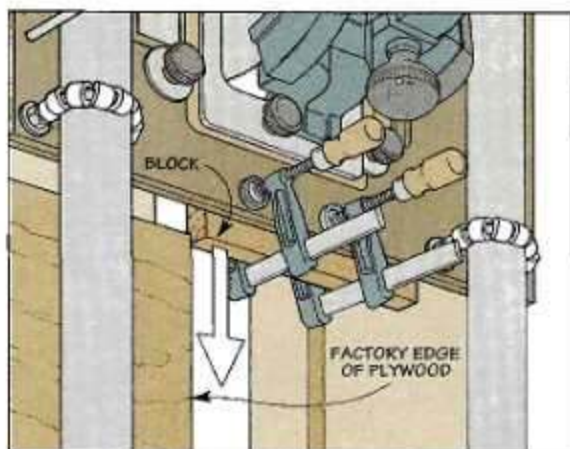
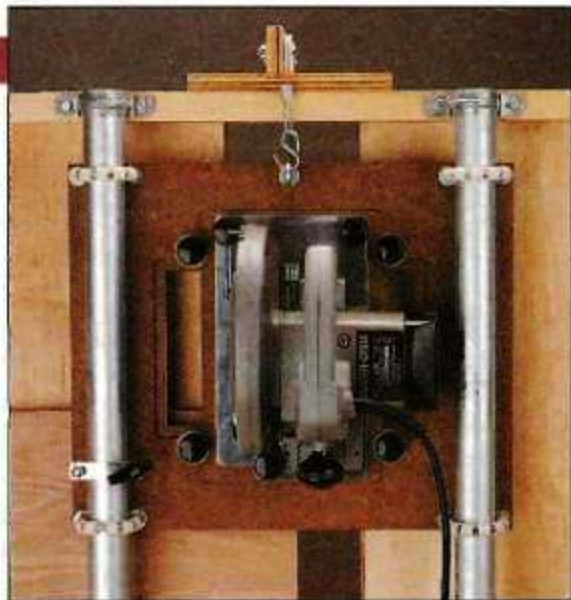

**Step 1:** Clamp a block to the carriage to align the guide tubes. Then push a sheet of plywood against the edge of the block, and slide the carriage up and down to check for a gap.

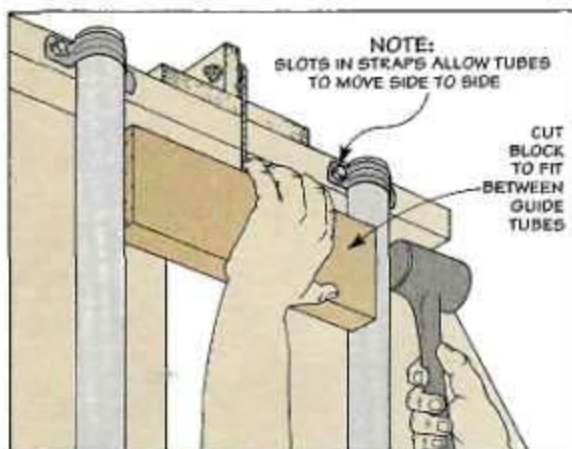

**Step 2:** To adjust the guide tubes, loosen the top or bottom conduit straps. Then tap the tubes into position. Cut a block to fit between the tubes to keep them parallel while they're adjusted.

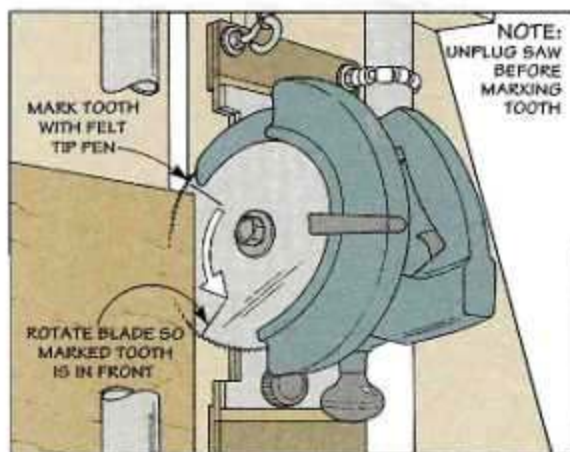

**Step 3:** The next step is to check the alignment of the saw blade. To do this, mark a tooth on the back side of the blade. Then rotate blade forward until marked tooth aligns with plywood edge again.

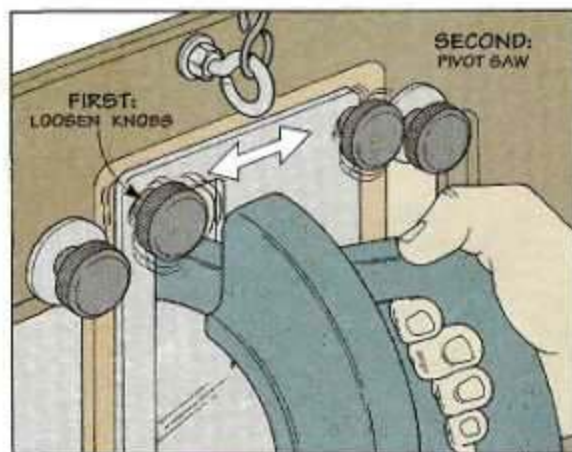

**Step 4:** If the distance between the marked tooth and the plywood edge varies, the saw needs to be adjusted. Loosen the knobs that hold the saw to the insert. Then pivot the saw to align the blade.



# Using the Panel Saw

*The panel saw is designed for precision crosscutting and ripping. And when you're finished cutting, it folds up flat for storage.*

## Ripping

When ripping large sheet goods, the carriage is locked and the workpiece is pushed through the blade, see photo at right. Setting up the saw for ripping requires a few simple steps.

First, mount the saw in the carriage so the blade is perpendicular to the guide tubes.

Then slide the carriage to the desired position and lock it in place. To do this, just tighten the T-knob against the strap on the square U-bolt, see Fig. 1.

If your saw doesn't have a lock switch, use a spring clamp to hold down the trigger switch during a cut, see Fig. 2.

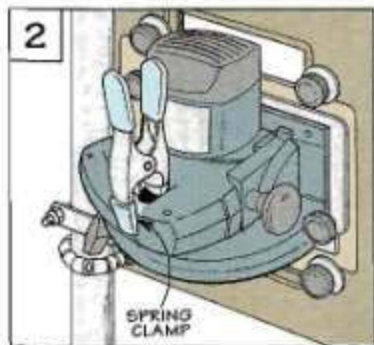
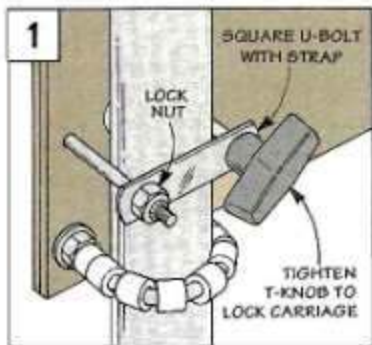

## Storage

Although the panel saw is a large tool, it's easy to move and store. That's because the back support can be folded up flat into the back of the bed when you're finished cutting, see photo at right.

When it's folded up, the saw lifts off the rear foot and the two edge rails and rests on the cast-

ers, see Fig. 1. Then you can roll the saw to another place in the shop, push it out to the driveway, or store it flat against a wall.

To hold the back support in an upright position when moving or storing the saw, lock the braces in place with the turnbuckles on the center rails, see Fig. 2.

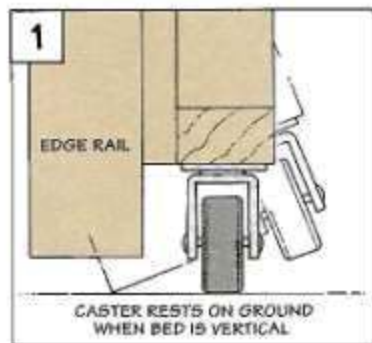

# Motor Vibration

*The secret to a smooth running machine is quality parts and alignment.*



Recently I purchased a used "contractor's style" table saw. (A belt-driven saw where the motor hangs from the back.) It seems like a sturdy, well-built machine. But when I turn the saw on, it shakes like a wet dog.

Is there anything I can do to correct the problem?

Any tool that shakes, bounces, or vibrates is not only inaccurate — it can be downright dangerous. Fortunately, there are several things that can be done to reduce vibration problems.

## WORN PARTS

Since you're dealing with a used machine, the first step is to check for worn parts. There are three basic components that need to be in good working order: the arbor shaft, the arbor bearings, and the motor itself.

Safety Note: Unplug the saw

before doing any adjustments.

**ARBOR SHAFT.** The arbor shaft is the business end of the saw. On one end is the saw blade, see Fig. 1. At the other end is a pulley. Examine the shaft. If it's worn or damaged, it should be replaced.

**ARBOR BEARINGS.** The next thing I check are the arbor bearings. They hold the shaft in place and allow it to spin freely.

To test the bearings for wear, remove the belt from the arbor pulley. Now, spin the arbor shaft by hand. It should spin freely without "catching" or grinding.

At the same time, check that the shaft is held securely in place. If it feels "sloppy," the bearings probably need to be replaced.

**MOTOR.** The third component that should be checked is the motor. A pulley that wobbles when the motor is turned on could mean a bent shaft, see Fig. 2. If this is your problem you'll need to

repair or replace the motor.

Once the basic components check out, the next step is to make sure they're aligned.

## MOTOR ALIGNMENT

For the saw to run smoothly the saw arbor and the shaft of the motor need to be in alignment.

**ALIGN SHAFTS.** This means aligning the motor from *above* the saw and from the *rear* of the saw, refer to Figs. 3 and 4.

There's nothing complicated about aligning the motor. All it requires is installing the belt and repositioning the motor on the mounting plate.

## PULLEYS

Once the motor shaft is aligned with the arbor shaft, the next step is to check the pulleys.

**ZINC-CAST.** A very common type of pulley is a zinc-cast pulley. Because the metal is soft in this

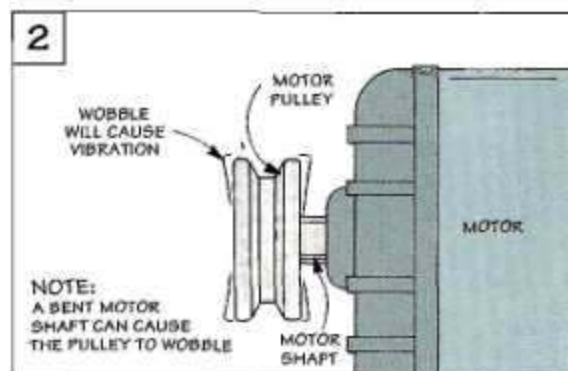
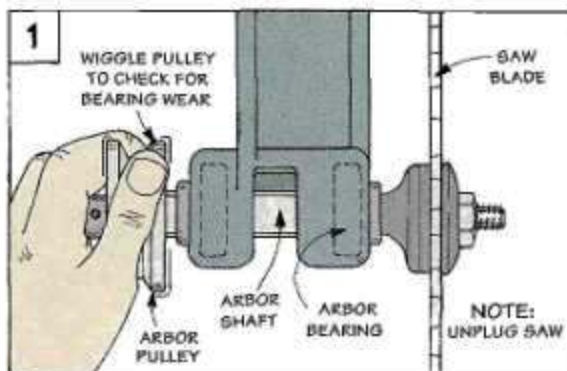

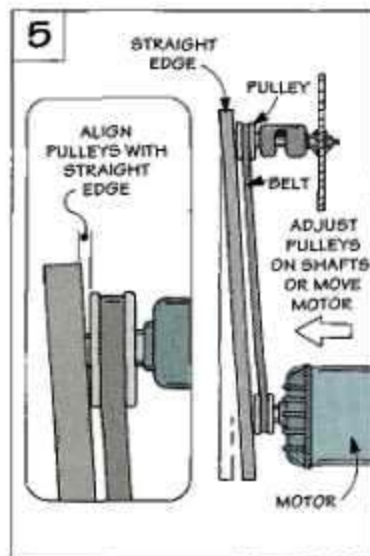
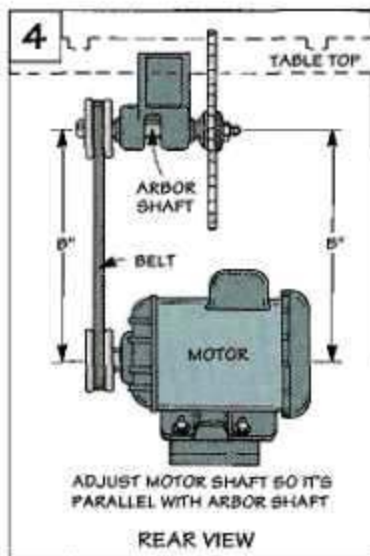
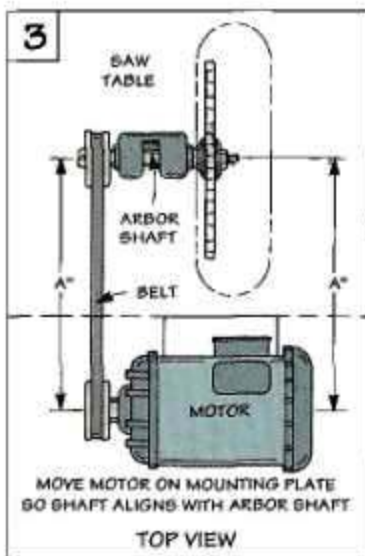

pulley, the sides are often bent. Or the center hole (bore) is deformed so it no longer fits tightly on the shaft.

Even if a zinc-cast pulley appears in good condition, I'd recommend replacing it. The reason is balance.

For a pulley to turn smoothly, it needs to be balanced, just like the wheel of a car. Zinc pulleys are not very well balanced. A better choice would be a turned steel or cast iron pulley.

**TURNED STEEL.** If possible, I prefer to use a turned steel pul-

ley. As the name says, these pulleys are turned from a solid piece of steel and are well balanced.

**CAST IRON.** It's impractical to turn large pulleys from a solid steel blank. So when replacing large pulleys, I use cast iron.

The only draw back to steel and cast iron pulleys is they cost more than zinc pulleys.

Regardless of the type of pulleys you use, they have to line up.

**ALIGN PULLEYS.** To determine if the pulleys are aligned, I use a straightedge, see Fig. 5. When held against the pulleys,

the straightedge should touch the outside edge of *both* pulleys. If the pulleys don't line up, try adjusting their position on the shaft. If you still can't get them aligned, you'll need to reposition the motor.

**V-BELT**

There's one last thing to check out — the V-belt. Over time this belt can stretch, crack, and become hard. Simply replacing the old belt with a new one can improve the saw's performance and reduce vibration.

**New Products**

While you're tuning up your saw, there's a couple of new products worth looking at: Power-Twist V-belts, and vibration pads.

**POWER TWIST BELT.** This belt is made of interlocking sections, so you can make any length belt you need, see Fig. 1. And it's designed to help reduce vibration.

**VIBRATION PAD.** This is basically a sheet of rubber-like material. The idea is to isolate the motor, which helps reduce noise and vibration, see Fig. 2. (See Sources on page 31.)

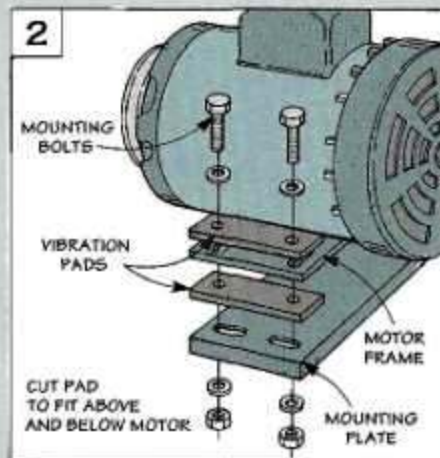
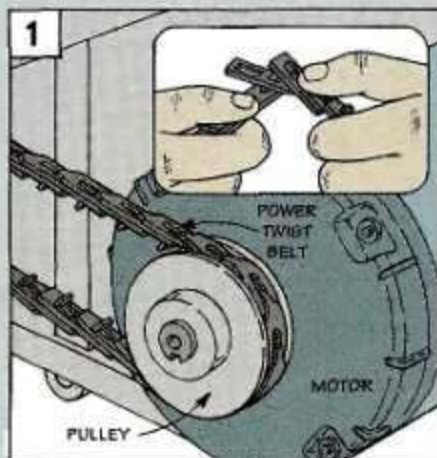

# Shop Solutions

## Saw Blade Storage Rack



■ I have several different blades for my table saw. Instead of hanging them on a nail, I built a storage rack that doubles as a filing system for the blades, see photo.

It lets me see at a glance which blade I need. And it keeps the blades from banging into one another and chipping the teeth.

The storage rack consists of two sides and a back that form a "U" shape, see Fig. 1. Diagonal slots cut in the sides hold the blades at an angle.

The only tricky part is getting the slots to match up. To do this, tape the sides together with double-sided carpet tape, and mark the slots on one piece, see Fig. 2. Then drill a  $\frac{1}{4}$ " hole to locate the end of each slot and cut the slots with a sabre saw.

To make it easier to insert the blades, cut off the corner of each slot, see Fig. 3. After gluing and screwing the sides to the back, I hung the storage rack on the wall near my saw.

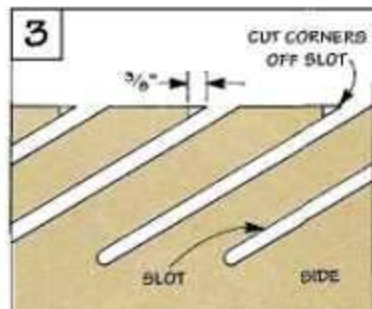
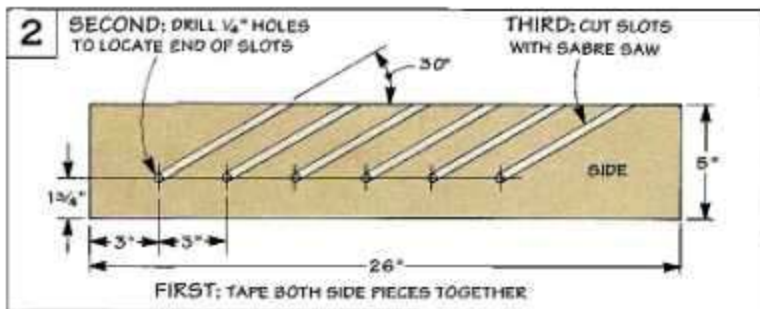
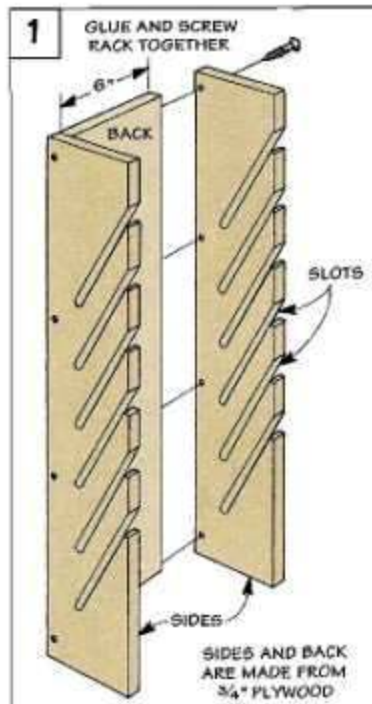

## Edge Jointing Tip

■ When making a pass on a jointer, I'm never sure when I've got a straight edge along the entire length of the board.

So I scribble a line on the edge I'm going to joint. Then I make a pass and check the edge. When the pencil line is gone, I know I've got a clean, straight edge.

Tom Hamer  
Woolstock, Iowa

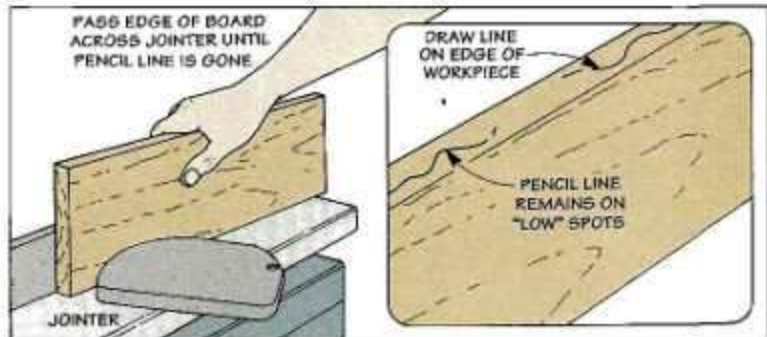

## Installing Threaded Inserts

■ I've used your tip about installing threaded inserts with a drill press on a couple of different occasions. (Editor's Note: This tip appeared in Issue No. 1 of *ShopNotes* on page 23.)

Sawing off the head of a bolt that fits the insert, and then chucking it in the drill press lets me drive the insert in straight and square.

The only problem is sometimes the bolt slips in the chuck, especially if I'm driving the insert into a piece of hardwood.

To prevent this, I grind three "flats" on the shank of the bolt, see Fig. 1b. The jaws of the chuck tighten against the flats and hold the bolt securely in place.

To install an insert, just thread a couple of nuts and the insert on

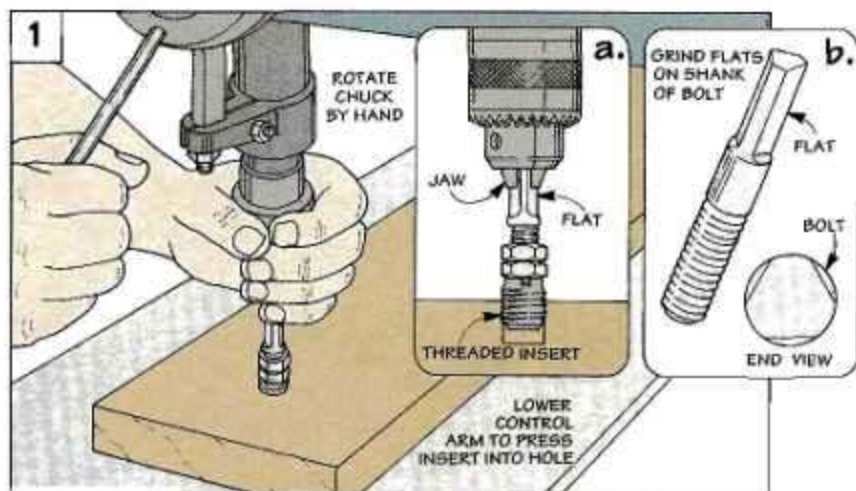

the end of the bolt, see Fig. 1a. Then, after tightening the nuts against the insert, chuck the bolt in the drill press.

Next, using the control arm of

the drill press, press the threaded insert into the hole while rotating the chuck by hand, see Fig. 1.

Joe Plyler

Charlotte, North Carolina

## Clamping Irregular Shapes

■ Clamping an irregular shaped workpiece in a bench vise can be a problem. If you exert enough pressure to hold the work, you may end up marring its surface.

One solution is to use scraps of polystyrene insulation as "vise pads," see drawing. When you tighten the vise, the insulation conforms to the shape of the workpiece without damaging it.

Bob Heidenreich  
Columbia, Missouri



## File Handles



■ Here's an easy way to install a handle on a file, see photo. All you need is an old dish brush with a plastic handle.

Clamp the brush in a vise and pull off the handle. Then heat the tang of your file and plunge it into the handle. The melted plastic grips the file in the handle.

Ed Quigley  
Belmond, Iowa

## Send in Your Solutions

If you'd like to share original solutions to problems you've faced, send them to: *ShopNotes*, Attn: Shop Solutions, 2200 Grand Ave., Des Moines, IA 50312.

We'll pay up to \$200 depending on the published length. Send an explanation along with a photo or sketch. Include a daytime phone number so we can call you if we have questions.

# Combination Screws

*A unique thread design and recess in the head make combination screws worth a closer look.*

The best thing about square drive screws is that it's almost impossible for a screwdriver to slip off the head as you drive them into a workpiece.

That's because these screws are designed for a screwdriver with a square tip that fits snugly in a square recess in the head of the screw, see drawing below. You can apply a lot more torque without the screwdriver slipping.

**CROSS-SLOTS.** These screws are also available with "cross-slots" in the corners of the recess — a combination between a square drive and a Phillips head screw, see photo.

This seems like the best of both worlds (especially if you can't always find a square drive screwdriver when you need one).

You can drive in combination screws easily with a square drive screwdriver. However, if you try

to use a Phillips screwdriver, the tip will probably slip out.

Why had cross-slots even been added? To find out, I talked to Jim Ray, president of McFeely's, a company that specializes in combination and square drive screws.

He said combination screws had originally been designed for the furniture industry. If a piece of furniture needed repair *after* leaving the factory (and a square drive screwdriver wasn't available), combination screws could still be easily *removed* with a Phillips screwdriver.

Jim also mentioned a couple of other advantages they have over "standard" woodscrews.

**DEEP THREADS.** First of all, combination screws have deeper threads than a standard woodscrew. Each thread takes a bigger "bite" so there's more holding power, see drawings below.



**PITCH.** Another key difference is the pitch or angle of the threads. On a combination screw, the bottom or *leading edge* of the threads rises up the shank at a sharp angle. As a result, it slices into the wood quicker, with less chance of splitting a workpiece.

You'd think a steep-angled thread would pull out easier. But it's just the opposite. The reason is the top or *trailing edge* of the thread is almost perpendicular to the shank of the screw. So it resists pullout like a barb on a hook.

**BRANDS.** Combination screws are available through several companies. As a result, there's a variety of brand names like Combo, Recex, and Square-X. (For a list of sources, see page 31.)

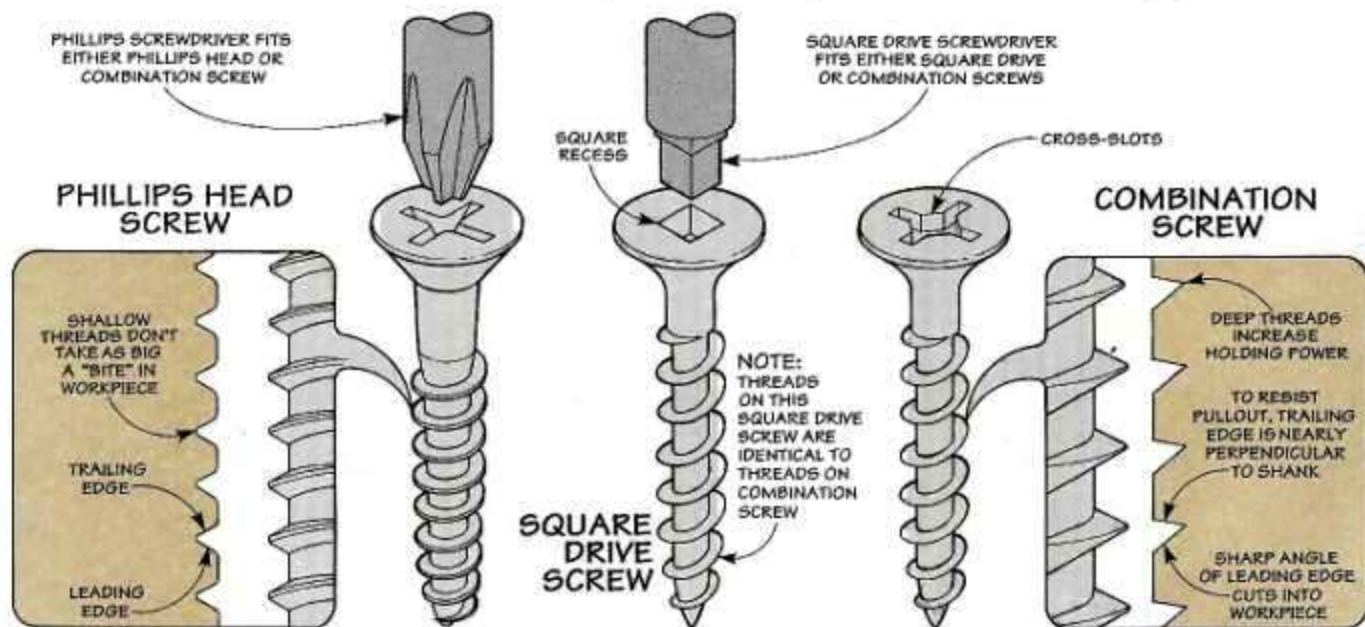

# Sources

*ShopNotes Shop Supplies* is offering some of the hardware and supplies needed for the projects in this issue.

We've also put together a list of other mail order sources that have the same or similar hardware and supplies.

## PATTERN BIT

The Hinge Mortising Jig on page 4 is designed to work with a pattern bit (1/2" dia. cutter). *ShopNotes Shop Supplies* is offering a 1/4"-shank pattern bit.

**S1514-160** Pattern Bit...\$22.95

## THICKNESS SANDING JIG

If you would like to purchase the hardware that we used to make the Thickness Sanding Jig on page 8, there's a kit available.

This kit contains the hardware only, not the wood.

**S6804-100** Thickness Sander Hardware Kit .....\$7.95

## DRUM SANDER

*Shop Supplies* is offering a kit of the hardware to make the Drum Sander shown on page 11.

This kit contains the wheels, carriage bolt, and the PVC pipe.

**S6804-200** Drum Sander Hardware Kit.....\$2.95  
*ShopNotes Shop Supplies* is also offering rolls of self-adhesive sandpaper for the Drum Sander.

These rolls are 4 1/2" wide and 10 yards long.

**S768-310** 80 Grit .....\$14.95

**S768-320** 100 Grit .....\$14.95

**S768-330** 120 Grit .....\$14.95

**S768-340** 180 Grit .....\$14.95

**S768-350** 220 Grit .....\$14.95

## SAW VISE

To make the shop-built Saw Vise on page 13, I used a plastic wing nut, a carriage bolt, and a washer.

**S6804-300** Saw Vise Hardware Kit .....\$1.95

A triangular file is also being offered. This is a 6" file with a sturdy plastic handle.

**S5001-121** Saw File .....\$4.95

## PANEL SAW HARDWARE KIT

*ShopNotes Shop Supplies* has a complete kit of all the hardware needed to build the Panel Saw.

The kit includes a phenolic carriage and insert. The carriage is pre-drilled and routed for the insert. All you have to do is attach the insert to your saw.

Note: This kit does not include the guide tubes, the PVC counterweight container, or the wood.

**S6804-400** Panel Saw Hardware Kit .....\$134.95

## ANTI-VIBRATION PAD

The rubber anti-vibration pad is available through *Shop Supplies* and from the mail order sources listed below. The pad is 12" x 12" and 1/8" thick.

**S5503-370** Rubber Anti-Vibration Pad.....\$13.95

## V-BELT

A 4-foot length of Power-Twist belt is available from *Shop Supplies*. This belt is an "A-section" (1/2"-wide) belt.

**S6804-500** Power-Twist Belt 4-feet long .....\$29.95

## COMBINATION SCREWS

*ShopNotes Shop Supplies* is offering a kit of Combination Screws. This kit includes 100 each of the following screws: No. 6 - 3/4" and 1"; No. 8 - 3/4", 1", 1 1/4", 1 1/2". The screws come in a divided storage box along with a power driver bit and a screwdriver.

Note: The No. 6 screws are square drive only.

## MAIL ORDER SOURCES

Similar hardware and supplies may be found in the following catalogs. Please call each company for a catalog or for ordering information.

**McFeeley's**  
800-443-7937  
Pattern Bit, Hardware,  
Combination Screws

**Garrett Wade**  
800-221-2942  
Hardware, Adhesive  
Sandpaper, Saw File,  
Anti-Vibration Pad

**Trend-Lines**  
800-767-9999  
Pattern Bit, Hardware,  
Sandpaper, Screws

**Woodcraft**  
800-225-1153  
Pattern Bit, Hardware,  
Adhesive Sandpaper,  
Saw File, Combination  
Screws

**The Woodworkers'  
Store**  
612-428-2199  
Pattern Bit, Hardware,  
Plastic Knobs, Combination  
Screws

**Woodworker's Supply**  
800-645-9292  
Pattern Bit, Hardware,  
Adhesive Sandpaper,  
Combination Screws

**Shopsmith/Wood-  
working Unlimited**  
800-543-7586  
Hardware, Adhesive  
Sandpaper

**In-Line Industries**  
800-533-6709  
Power-Twist V-belt

## ORDER INFORMATION

### BY MAIL

To order by mail, use the form enclosed with a current issue. The order form includes information on handling and shipping charges, and sales tax. Send your mail order to:

**ShopNotes  
Shop Supplies**  
P.O. Box 842  
Des Moines, IA 50304

### BY PHONE

For fastest service use our Toll Free order line. Open Monday through Friday, 7:00 AM to 7:00 PM Central Time.

Before calling, have your VISA, MasterCard, or Discover Card ready.

**1-800-444-7527**

Note: Prices subject to change after Sept. 1, 1992.

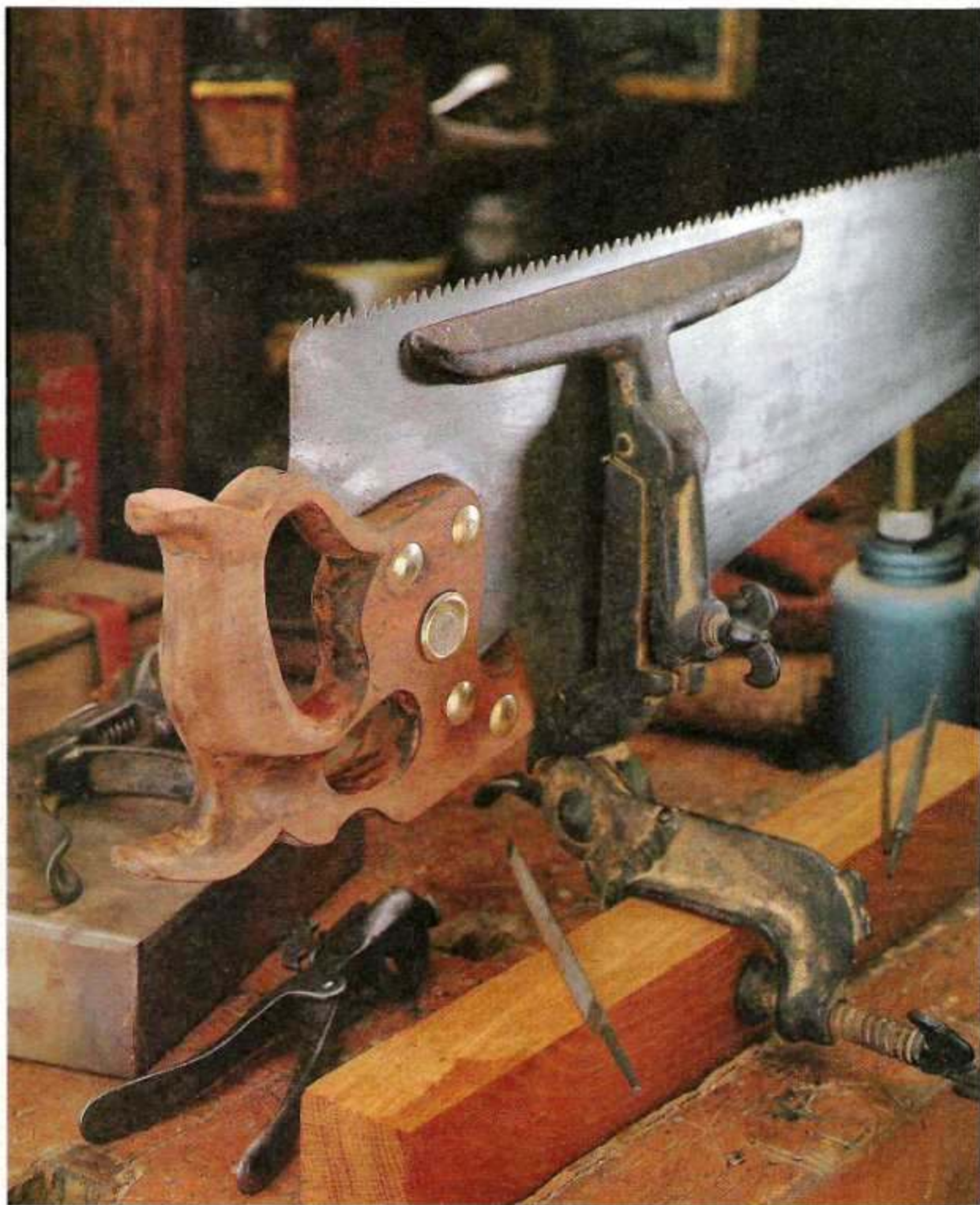

## Scenes From the Shop

*This old Disston hand saw will take as keen an edge today as it did when it was made years ago. Likewise, the tools used to sharpen a saw have changed little over*

*the years — a cast iron saw vise to hold the blade, a saw set to bend the tips of the teeth, and a triangular file to create a razor sharp cutting edge.*