

TIPS • TOOLS • TECHNIQUES

ShopNotes™

\$4.95

Issue 3

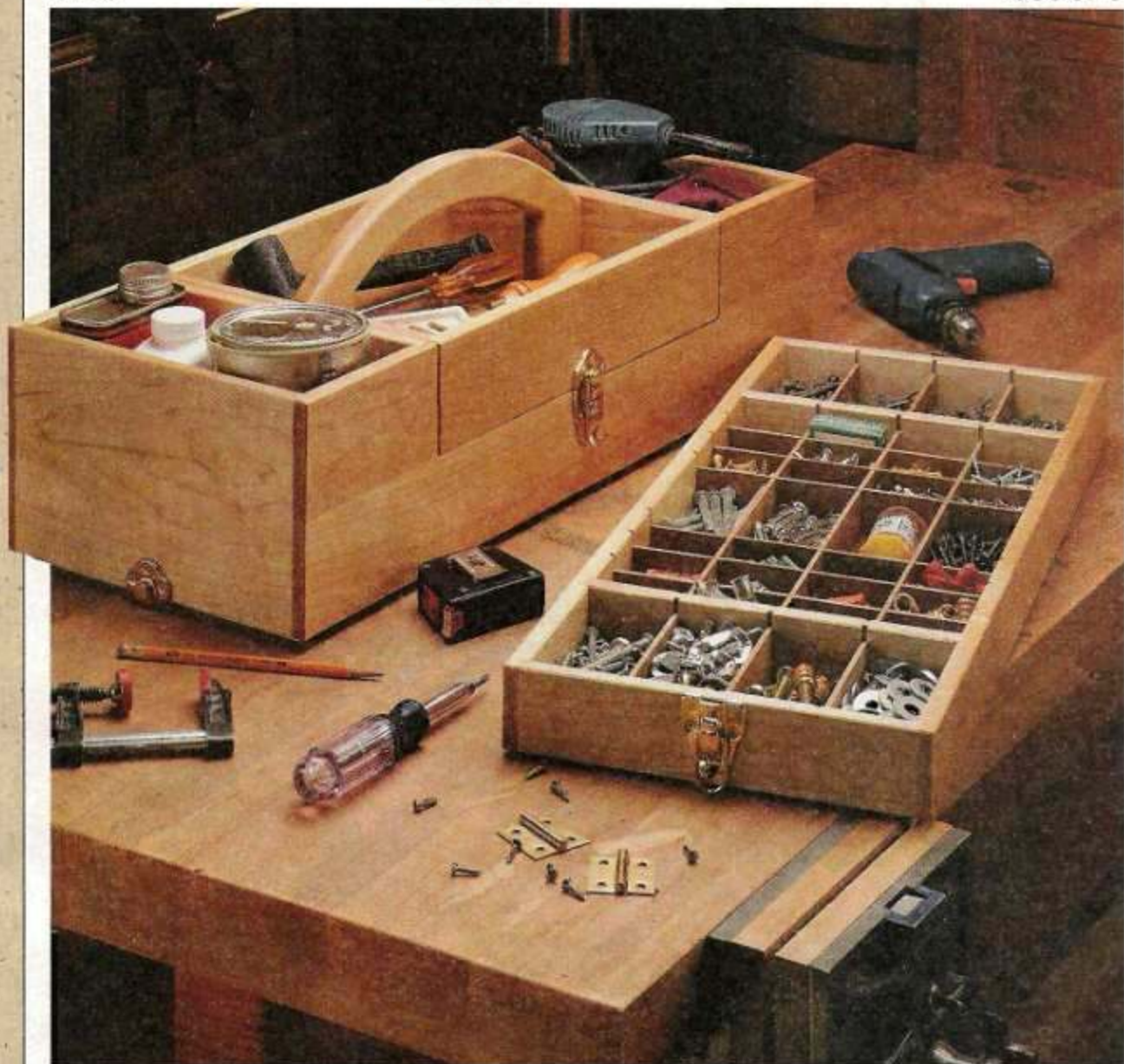

- Handy Tool Carry-All
- Shop-Built Clamping Station
- Plate Joinery Techniques
- Adjustable Grinding Jig



ShopNotes

Issue 3

May 1992

EDITOR Donald B. Peschke
EDITORIAL DIRECTOR Douglas L. Hicks
MANAGING EDITOR Terry J. Strohman
ASSISTANT EDITORS Richard S. Peters
 Tim Robertson
CREATIVE DIRECTOR Ted Kralicek
ART DIRECTOR Cary Christensen
ILLUSTRATORS Kurt Schultz
 Will Niskanen
 Roger Reiland
CONTRIBUTING ILLUS. Robert H. Whitmer
DESIGN DIRECTOR Ken Munkel
DESIGNER Jan Hale Svec
PHOTOGRAPHER Crayola England
SHOP MANAGER Steve Curtis

CIRCULATION DIRECTOR Liz Bredeson
SUBSCRIPTION MANAGER Phyllis Jessen
CIRCULATION ANALYST Jim Woodson
NEWSSTAND SALES Kent A. Buckton

CONTROLLER Paul E. Gray
ACCOUNTING Linda O'Rourke
BOOKKEEPING Julianne Spears
NETWORK ADMIN. Douglas M. Lidster
ADMINISTRATIVE ASST. Cheryl Scott
RECEPTIONIST Lori Seibert
BUILDING MAINTENANCE Ken Griffith

MARKETING DIRECTOR Robert Murry
SHOP SUPPLIES ART DIR. Cindy Jackson
CUSTOMER SERVICE MGR. Laura McNelly
PROJECT SUPPLIES Leslie Ann Gearhart
 Linda Jones
TECHNICAL SUPPORT Jonathan Garbison
SYSTEMS OPERATOR Linda Morrow
RECEPTIONIST Keri Lee
CUSTOMER SERVICE
 Jennie Enos (Supr.), Marci Nelson, Jeff
 Janes, Joy Johnson, Sara Johnson,
 Ami Blanshan
SHIPPING DEPARTMENT
 Jerry Carson (Supr.), Gloria Sheehan,
 Ronald Long, Don McVey, Chuck Carlson

ShopNotes is published bimonthly (January, March, May, July, September, November) by Woodsmith Corporation, 2290 Grand Ave., Des Moines, IA 50312. Printed in U.S.A.
 ShopNotes is a trademark of Woodsmith Corporation. ©Copyright 1992 by Woodsmith Corporation. All rights reserved.
 Subscriptions: Single Copy, \$4.95. One year subscription (6 issues), \$19.95. Two years (12 issues), \$35.95. Canada/Foreign, add \$4.00 per year.
 Second Class Postage Pending at Des Moines, IA and at additional offices.
 Postmaster: Send change of address to ShopNotes, Box 11204, Des Moines, IA 50340-1204
 Subscription Questions? Call 1-800-383-6864, 8am to 5pm, Central Time, weekdays.

EDITOR'S NOTE

Almost every weekend in our shop somebody is making a project for their home. On a couple of occasions this past winter the project was a major one — making new kitchen cabinets.

In both cases, most of the joinery for the cabinets was done with biscuit (or plate) joints. Plate joinery is not used much in traditional furniture making. But it has caught hold for production-type cabinet work.

The idea behind plate joinery is very simple. You just cut slots in the two pieces to be joined. Then glue a pressed-wood biscuit in the slots.

When I first tried it, my initial reaction was, "It's easy and fast, but the joint probably isn't very strong."

I wasn't prepared to give up mortise and tenon joints for these little biscuits. But the resulting joint is stronger than you might think. I was surprised . . . and impressed.

There are limitations, of course. Biscuits won't replace all traditional joinery methods. (Although they have just about replaced dowels in my shop.)

I'm convinced that plate joinery is a technique worth adding to the tool box, particularly in two circumstances. First, for corner joints — like joining the four corners of a cabinet. And second, for making mitered joints — as on a cabinet or drawer with mitered corners.

The only drawback is that you have to buy a rather expensive plate joiner to cut the slots for the biscuits.

A few years ago, the market for plate joiners was fairly limited — it centered around the Lamello biscuit joiner, an expensive tool from Europe, where plate joinery originated.

Now the field has widened, and the price has come down. So we decided to take a look at four plate joiners that you can buy for under \$250 (page 20).

JIGS. Aside from plate joinery there are two jigs in this issue that I really like. First, we came up with a handy device for holding your chisel or plane iron to grind a precise angle on a grinding wheel (page 6).

The other jig that's worth some attention is the clamping station (page 22). Even if you don't build the entire clamping table, the little clamp cradle is worth a close look (see photo on page 22).

ADDITIONS. Every drawing shown in ShopNotes requires a surprising number of hours of creative effort. The team that creates the artwork is lead by our newly promoted art director, Cary Christensen. He and Kurt Schultz have worked a lot of late evenings since the first issue to get the artwork done.

We wanted to add to the staff to help these two guys. We had to find talented illustrators who also know and understand woodworking. Will Niskanen and Roger Reiland were just what we were looking for.

The whole idea behind their work is to spend hours creating an illustration — so you can look at it for only a few seconds to get all the information you need.

We hope you enjoy this issue.

Contents

Slip-on Auxiliary Fence _____ 4

This auxiliary fence slips over your rip fence so you can cut rabbets or support tall workpieces.

Bevel Grinding Jig _____ 6

Grinding a precise, even bevel on a chisel or plane iron is easy once you've built this handy jig.

Router Trammel _____ 8

Cut perfect circles or arcs with your router and this shop-made trammel.

Tool Carry-All _____ 10

A removable tray for small jobs and a storage tray for organizing parts and hardware are just two of the features of this handy Carry-All.

Plate Joinery _____ 16

Make tight-fitting joints quickly and easily by cutting matching slots and then gluing in a wood "biscuit."

Plate Joiners _____ 20

A review of four plate joiners priced for the home workshop: Ryobi, Freud, Porter-Cable, and Skil.

Clamping Station _____ 22

A flexible clamping station for gluing-up perfectly flat panels and frames. And it doubles as an assembly area.

Shop Solutions _____ 26

Four shop-tested tips: A Drill Press Clamp, Scraper Holder, Shop-Made Bench Vise, And a Tip for Storing your Shop Manuals.

Toggle Clamps _____ 28

A look at these versatile clamps along with tips and ideas on how to use them in your shop.

Sources _____ 31

Hardware, project supplies, and mail order sources for the projects in this issue.



Bevel Grinding Jig page 6



Tool Carry-All page 10



Plate Joinery page 16



Clamping Station page 22

Slip-on Auxiliary Fence

This slip-on fence makes it easy to cut rabbets (or tenons) on the end of a workpiece. It also provides support when cutting tall workpieces.

■ One of the quickest and easiest ways to cut a rabbet on the end of a workpiece is to use a dado blade on the table saw.

To do this, part of the dado blade needs to be "buried" in a wood auxiliary fence, see photo. Clamping on a wood fence is fast, but clamps can get in the way.

Instead, I use an auxiliary fence that quickly slips over my rip fence. And by making the fence 7"-tall, I can use it to support a tall workpiece, see photo at bottom of page 5.

FENCE CONSTRUCTION

The slip-on fence consists of two tall sides held together with a pair of spacer strips.

SIDES. Start by cutting two



sides (A) from 3/4"-thick plywood. Cut the sides 3" longer than your rip fence to allow for clearance (and for two stop blocks that are added later), see Exploded View.

SPACER STRIPS. After the sides are cut to size, the next step is to make the spacer strips (B). (I used plywood for these strips since solid wood strips could

warp and twist the side of the fence.) These strips are the same length as the sides, and exactly as wide as your rip fence, see Exploded View.

CHECK FIT. To check the fit of the strips, temporarily clamp the fence together so one strip is flush with the top, and the other is 1/8" above the rip fence. Then slide the fence over your rip fence

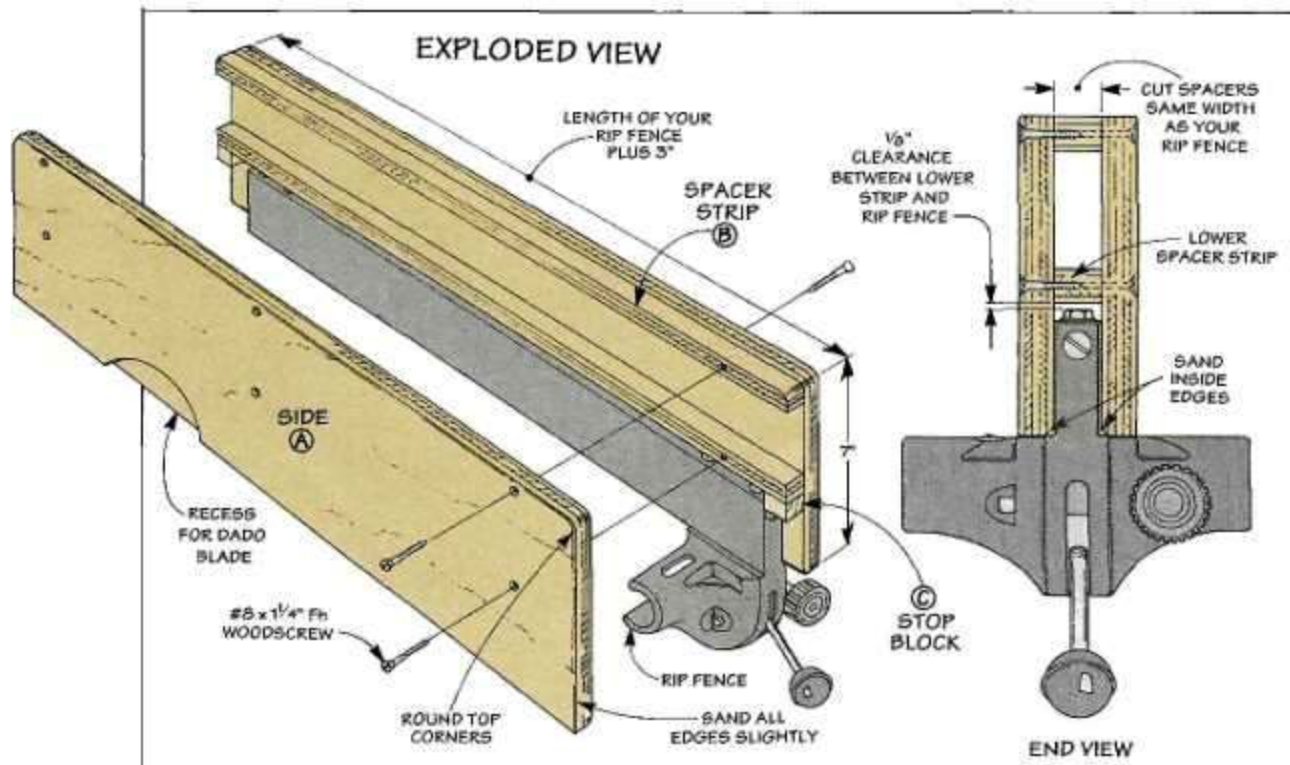

to see how it fits, see Fig. 1.

If it's too loose, carefully rip down the strips. If you get it too tight, see the Shop Tip at right.

Once you've got a snug fit, drill pilot holes, and screw the fence together, see Fig. 1.

STOP BLOCKS. To prevent the slip-on fence from sliding forward during use, stop blocks are mounted on both ends to catch the ends of the rip fence, see Exploded View.

Cut a pair of *stop blocks (C)* to the same width as the spacer strips, and about 1" long. Then glue them to the lower spacer strip so they just catch the end of the rip fence, see Figs. 2 and 2a.

Then I rounded over the top corners of the fence and sanded a round-over on all the edges.

CUT RECESS. To use the fence to cut rabbets, you have to cut a recess for the dado blade. First, mount a dado blade in the saw and lower it all the way down. Then slip on the auxiliary fence.

Now slide the fence over the dado blade to cut a 5/8"-wide recess in the inside face of the slip-on fence, see Fig. 3a. Then clamp the slip-on fence to the saw table.

To cut the recess, turn on the saw and slowly raise the blade, see Fig. 3. The recess only needs to be about 1/2" high since that's the maximum cut you'll need for most work with 3/4"-thick stock.

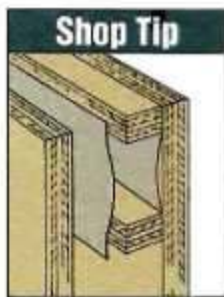
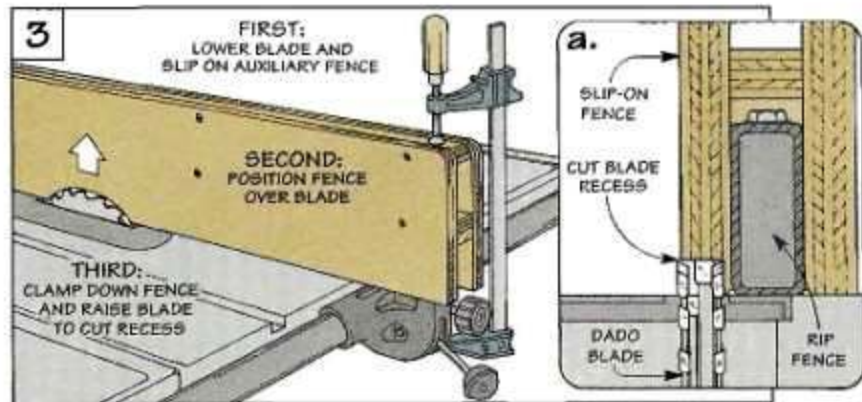
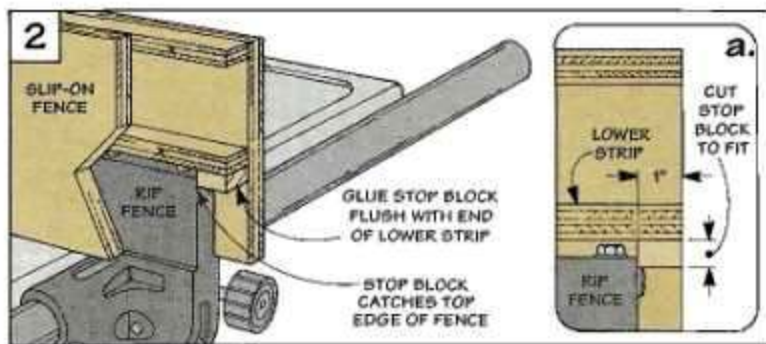
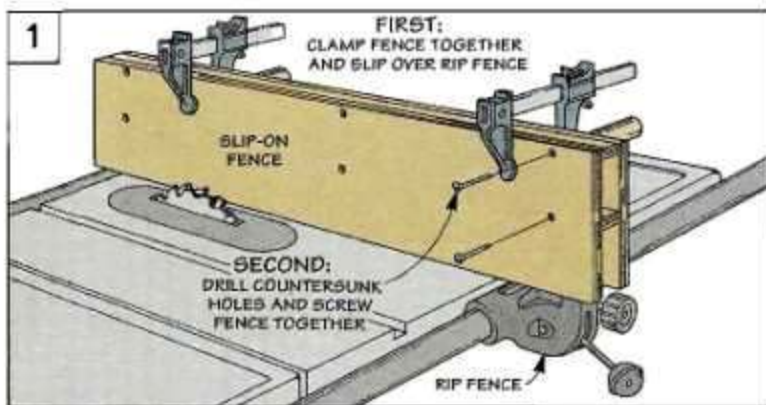

Shop Tip
If the slip-on fence is too tight, add a strip of paper or masking tape as a shim.



▲ **Easy on and off.** This fence is designed so you can slip it on or off your metal rip fence. And you don't need clamps or screws to hold it in place.

▲ **Extra support.** One side of the auxiliary slip-on fence is left smooth to provide uniform support when cutting wide or tall workpieces.

Bevel Grinding Jig

Using this jig makes it easy to grind a perfect bevel on a chisel or plane iron.

■ The first step to getting a razor sharp edge on a tool is to grind the correct bevel. A bench grinder can do this very quickly—sometimes too quickly.

A grinder cuts so fast that if the tool isn't held at the correct angle, or remains in one spot too long, the bevel can be ruined.

FEATURES. To solve this problem I built a grinding jig, see photo. This jig holds the tool at the correct angle while you slide it across the grinding wheel. It even has a built in "stop" to set the angle and to prevent you keep from grinding too far.

TWO PARTS. The jig is made in two separate parts: a cradle and a carriage assembly.

CRADLE

The cradle supports the carriage assembly (which holds the tool) and is clamped down in front of the grinding wheel. (For more on this, see the bottom of page 7.)

To make the cradle, start by cutting the *base (A)* to size, see Fig. 1. Attached to the base are

two *cradle support arms (B)*. To get the carriage (and the tool itself) closer to the grinding wheel, the ends of the support arms are cut at an angle, see Fig. 1.

Next, notches are cut in the top ends of the support arms to hold the carriage assembly rod, see Fig. 1a. After the notches are cut, screw the support arms to the base, see Alignment Tip below.

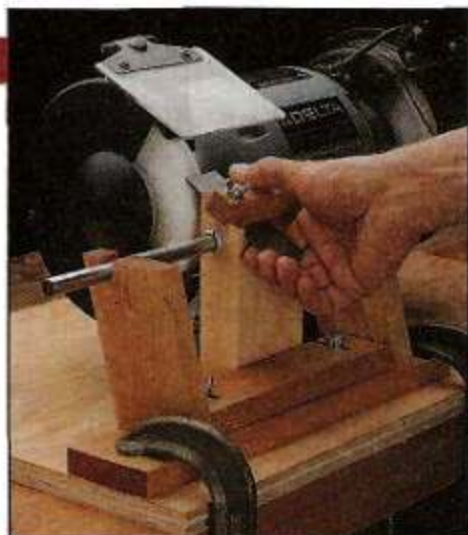

STOP BAR. Later, when the carriage is mounted to the cradle, the angle of the carriage (and thus the grinding angle) is adjusted by a *stop bar (C)*, refer to Step 3 in Fig. 7. Cut this bar and mount it to the base, see Fig. 2.

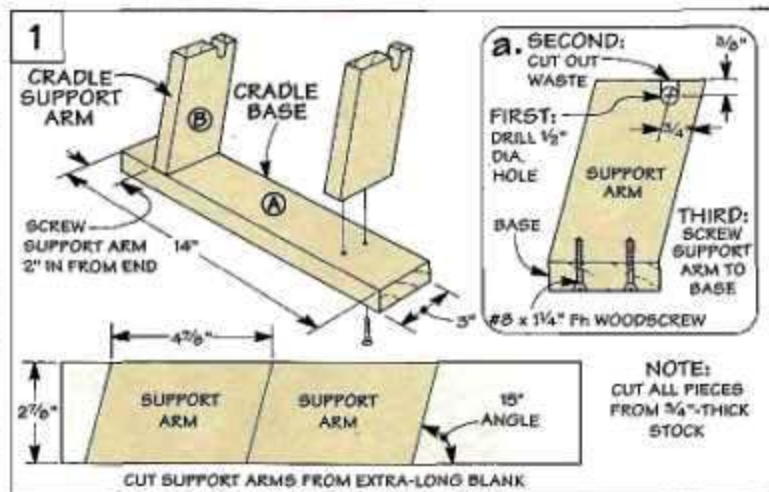

Alignment Tip

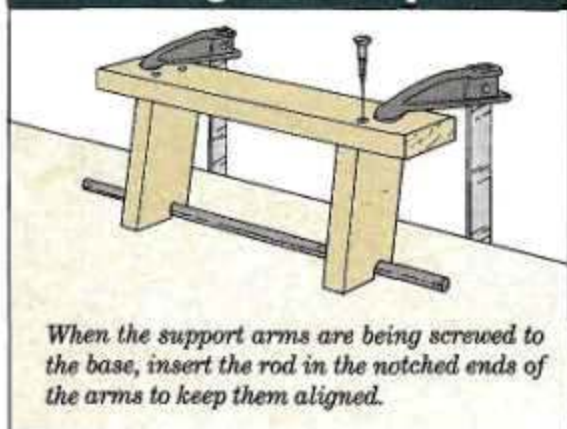

When the support arms are being screwed to the base, insert the rod in the notched ends of the arms to keep them aligned.

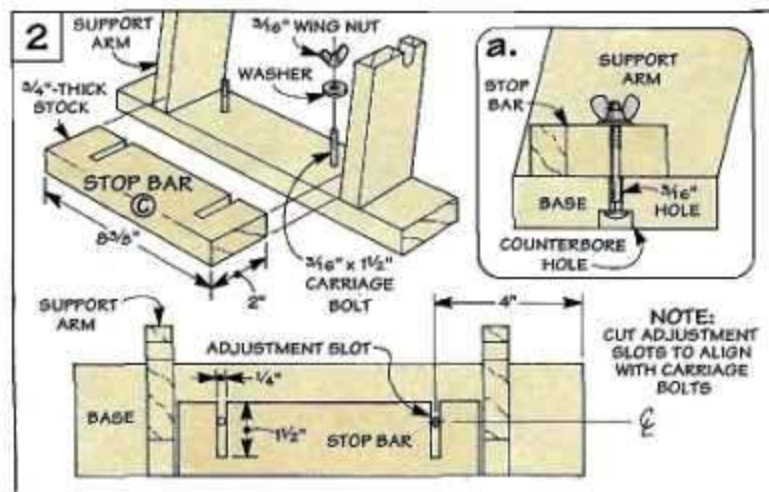

CARRIAGE ASSEMBLY

The carriage assembly is the heart of this jig. It holds the tool in the correct position for grinding. And it slides side-to-side, allowing you to grind a consistent bevel across the end of the tool.

Three parts make up the carriage assembly: the carriage block, the support rod, and the pressure bar.

CARRIAGE BLOCK. The carriage block is made from three pieces: a *center piece* (D) and two *side pieces* (E), see Fig. 3. The side pieces are glued to the center piece so they extend $\frac{1}{4}$ " above the center piece. This creates a lip to position the tool against.

SUPPORT ROD. After gluing up the carriage block, the next step is to drill a hole in the block to insert the support rod.

This round rod rests in the notched support arms and allows the carriage block to pivot so you can gently tip the end of the tool against the grinding wheel, see photo at the top of page 6.

PRESSURE BAR. To hold the tool to the carriage block, I attached a *pressure bar* (F), see Fig. 4. This bar has a filler strip attached to the bottom. The pur-

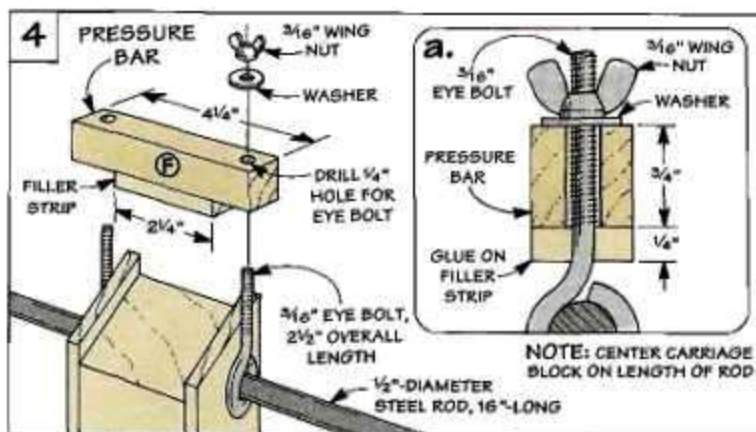
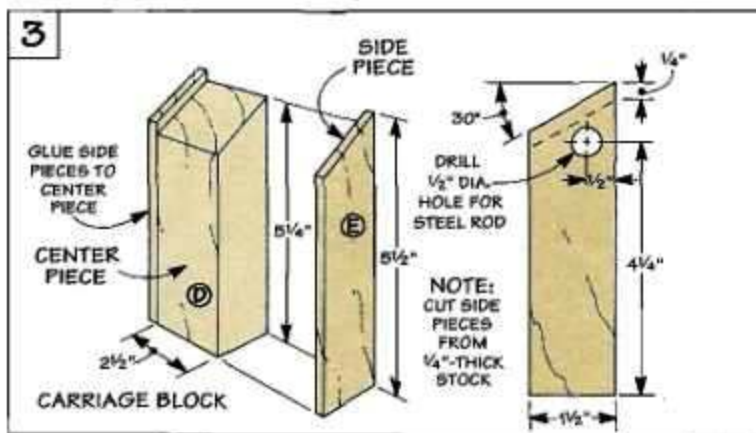

pose of this strip is to fit between the extended sides of the carriage block and put pressure directly on the tool, refer to Step 2 below.

The pressure bar is clamped

down to the carriage block with a couple of eye bolts and wing nuts, see Fig. 4a. These eye bolts slide over the support rod. (For hardware information, see page 31.)

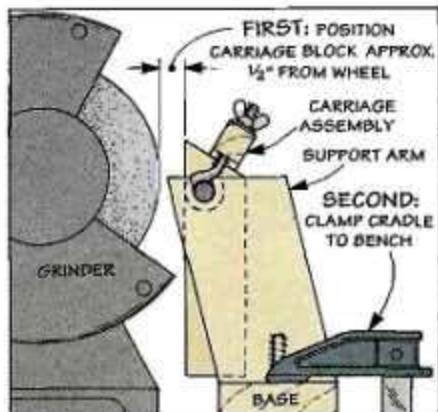

Step 1: Center the cradle in front of the grinding wheel, and remove the stop bar from the cradle base. Now clamp the cradle so the carriage block is about $\frac{1}{2}$ " away from the wheel.

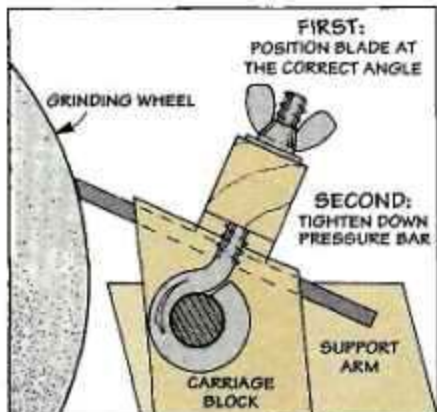

Step 2: Slip the plane blade under the pressure bar, and loosely tighten the bar. Now adjust both the angle of the carriage block and the position of the blade to get the desired angle.

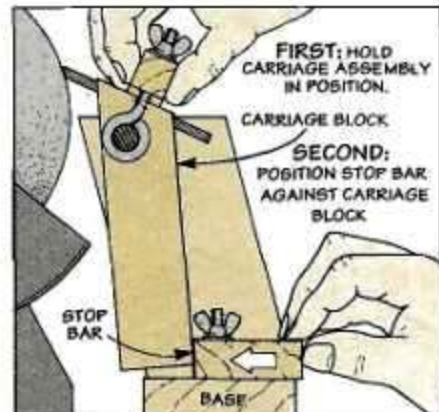

Step 3: When the angle is set, tighten the stop bar against the bottom end of the carriage block. To grind the bevel, tip the blade into the grinding wheel while moving the carriage side-to-side.

Router Trammel

All you need is three pieces of Masonite to make this adjustable trammel for your router.

You can rout perfect circles or arcs by attaching this adjustable trammel to your router.

Besides being easy to use, this trammel is also easy to make. There are just two basic parts: a base, and an adjustment arm, see Exploded View.

BASE. The trammel base is made by gluing two pieces of Masonite together, refer to Fig. 2.

The width of the top and bottom pieces (A,B) is determined by the size of your router base. (In my case, this is 6".)

But the length of these pieces depends on the size of circle you want to rout. To rout circles up to four feet in diameter, I decided to make the bottom piece 24" long.



To allow room for mounting the router, the top piece is cut 6" shorter than the bottom piece. (Here again, this depends on the size of your router base, see Ex-

ploded View.) Cut both pieces to size. Then drill a hole in the bottom piece, centered on the width for the router bit to fit through, see Exploded View.

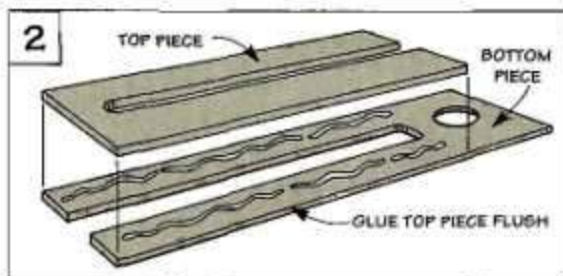
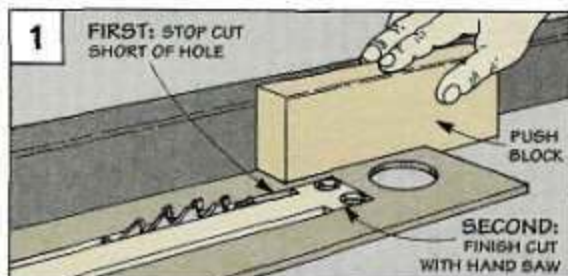
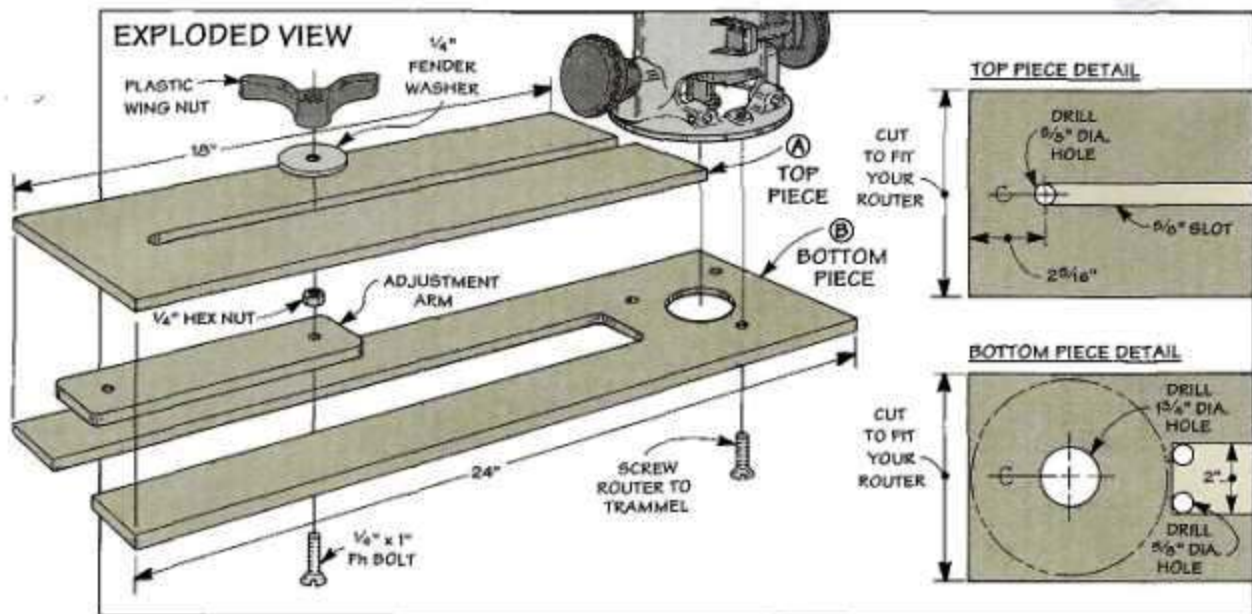

SLOTS. After cutting the top and bottom pieces to size, the next step is to cut slots down the center of each piece.

The bottom piece has a 2"-wide slot down the middle that holds the adjustment arm. The top piece has a slot to allow a bolt to pass through to lock the adjustment arm in place, see Fig. 3.

CUT SLOTS. To make the slots, first drill $\frac{5}{8}$ "-dia. holes to locate the ends of each slot, see Exploded View. Then when cutting the slots, stop about $\frac{1}{2}$ " before reaching these holes, see Fig. 1. (This will prevent the waste piece from kicking back.) Then finish the cut with a hand saw.

To complete the base, simply glue the top and bottom pieces together, see Fig. 2.

ADJUSTMENT ARM. Next, an adjustment arm (C) is cut to fit the slot in the bottom piece, see Fig. 3. It's mounted to the base with a bolt and wing nut (see Sources on page 31).

TIP. There's a trick to using this arm. For small circles, mount the arm so the pivot hole is near the router, see Fig. 3. For large circles, rotate it so the hole extends out the end of the base.

MOUNT ROUTER. All that's left to do is to mount the trammel base to your router. To do this, use the base on your router to

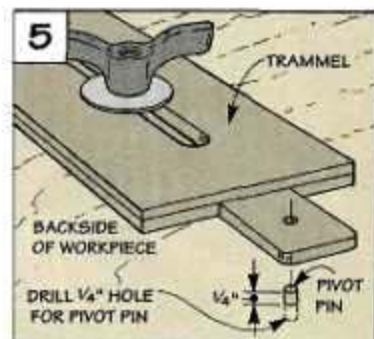
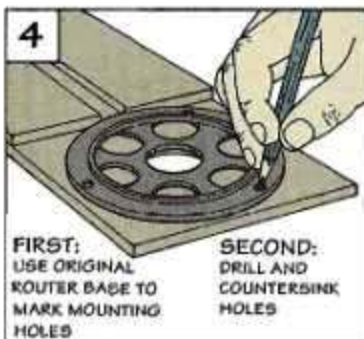
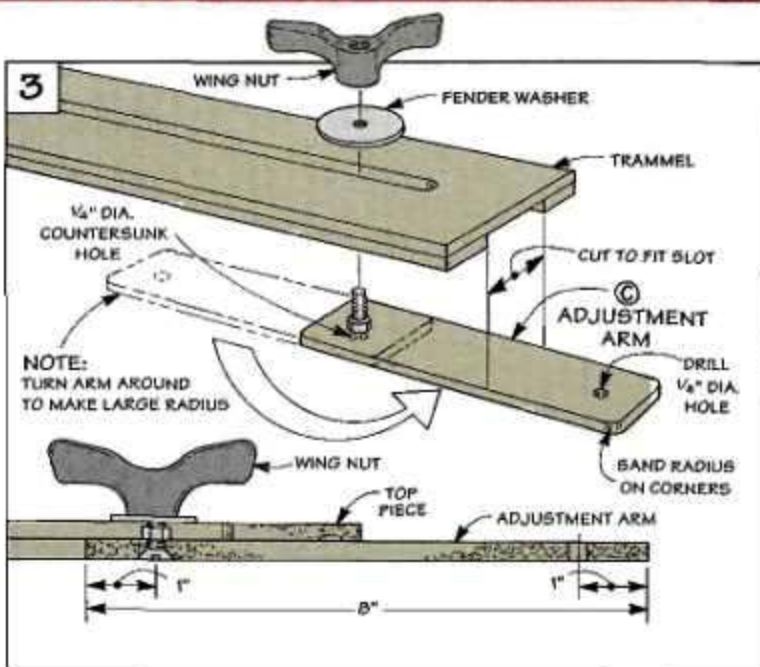

locate the screw holes, see Fig. 4. Then drill countersunk holes and screw the trammel to your router.

ROUTING CIRCLES. To rout a circle, drill a hole in the backside

of the workpiece. Then insert a pivot pin (a short piece of dowel), and place the pivot hole over the pin. Adjust the trammel arm, and rout the circle, see Fig. 5.

Auxiliary Plates

The router trammel is designed to work from the backside of a workpiece. But there are times when you may want to rout from the "good side." This can be done with a couple of auxiliary plates, see drawing.

Instead of drilling a hole for the pivot pin, simply use carpet tape to fasten the pivot plate on the workpiece. Then to keep the trammel level, tape another plate to the trammel directly under the router.

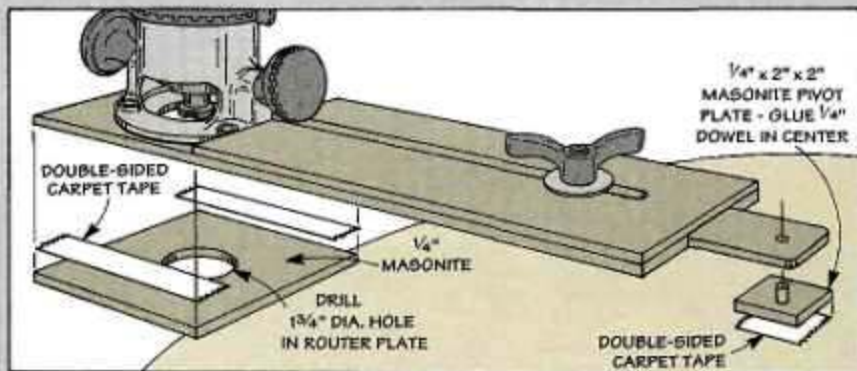

Tool Carry-All

This Carry-All makes it easy to transport tools, parts, and hardware right to where you're working ... all in one trip.



Sometimes mistakes have a happy ending. When I built the prototype of this Tool Carry-All, I made the bins quite deep. I thought I could get more stuff in them if they were deeper.

But after I cut all the pieces and test clamped it together, the open bins seemed too deep. So I disassembled the case and ripped a 2"-wide strip off the bottom of

each piece.

As I began to toss these cut-offs into the scrap pile, I realized that I had most of the parts necessary to make a storage tray. Not only that, the tray was sized to fit perfectly under the case and the joinery was already done.

This method of building over-size bins first, and then ripping

the bottom pieces off for the storage tray worked well. In fact, I decided to use this technique for the version shown here.

CONSTRUCTION

I started work on the Carry-All by edge-gluing enough 1/2"-thick hardwood (I used maple) to make two side blanks (A,G), see drawing at left.

SIDE BLANKS. Each U-shaped side blank is formed in two steps. First, cut a piece 5 1/8" wide by 25" long for the bottom of the "U," see drawing. Then cut two pieces 3" wide by 5 1/2" long and glue them to the top edge to form the "U" shape.

Note: This creates blanks that are oversized to include enough height for the storage tray.

END/DIVIDER BLANKS. After the side blanks are complete, the next step is to glue up 1/2"-thick stock to make four blanks for the ends (B,H) and dividers (C,I), see drawing. (Note the grain direction.) Here again, I made the blanks oversized for the storage tray.

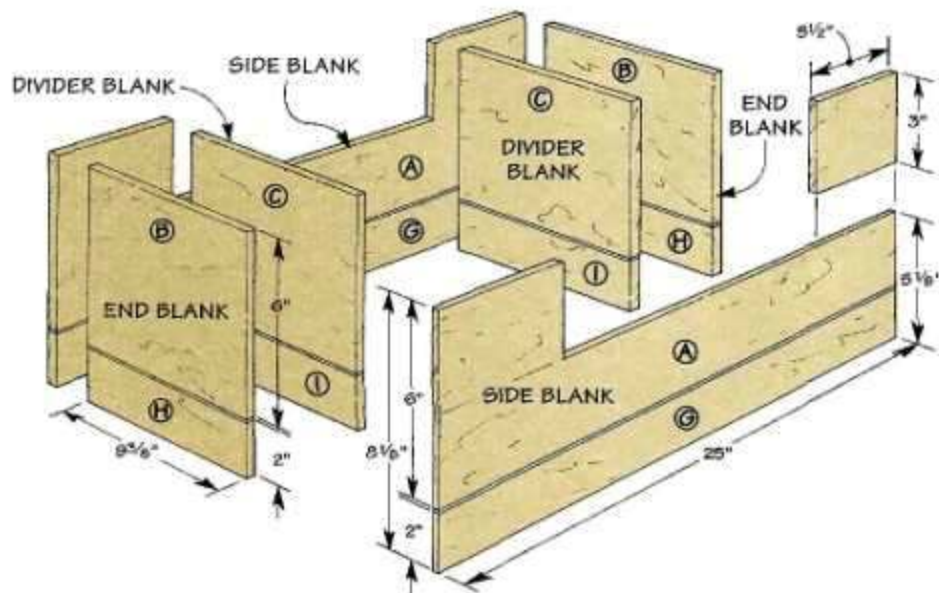

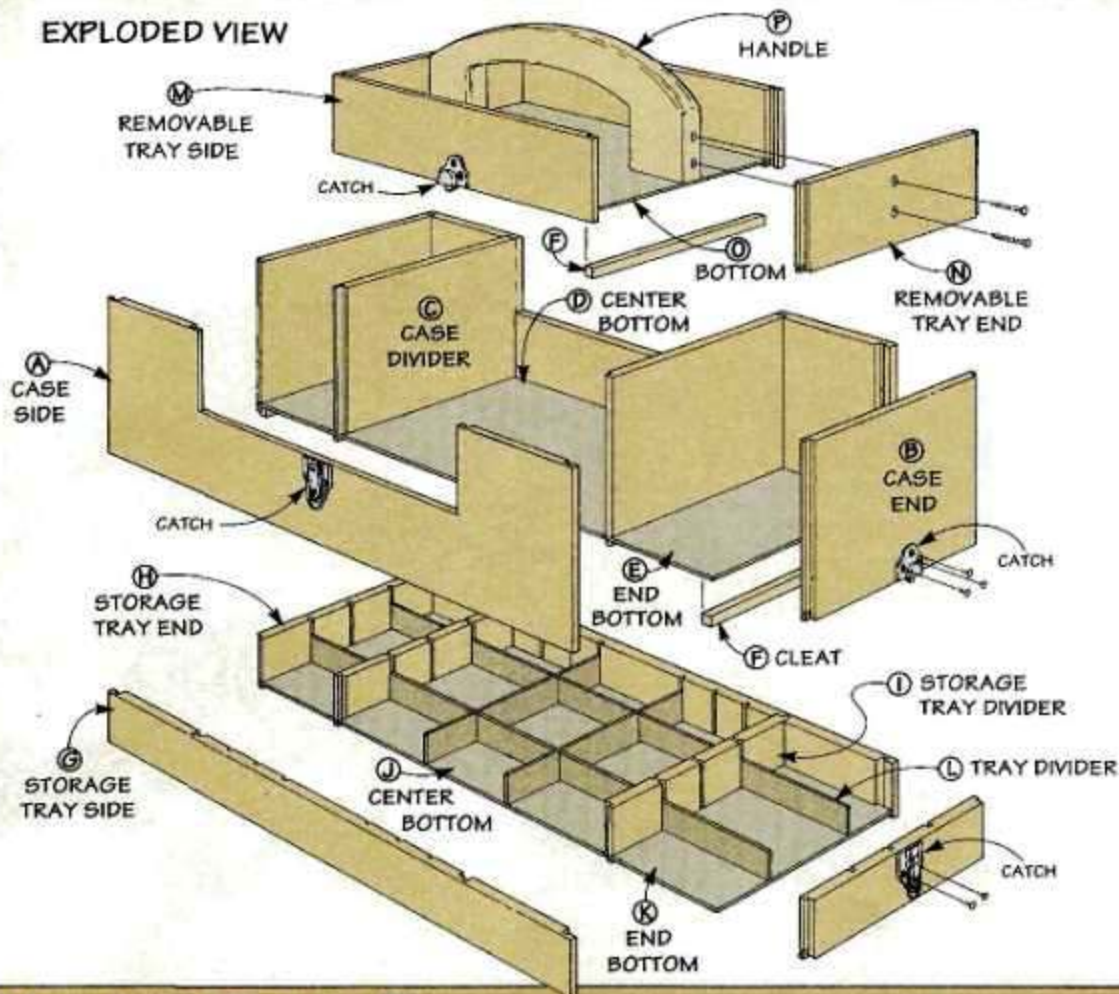

Materials - Cutting Diagram

Case

- A Sides (2) $\frac{1}{2} \times 6 - 25$
- B Ends (2) $\frac{1}{2} \times 6 - 9\frac{3}{8}$
- C Dividers (2) $\frac{1}{2} \times 6 - 9\frac{3}{8}$
- D Center Bottom (1) $9\frac{1}{8} \times 14\frac{1}{4} - \frac{1}{8}$ Masonite
- E End Bottoms (2) $9\frac{1}{8} \times 4\frac{3}{4} - \frac{1}{8}$ Masonite
- F Cleats (4) $\frac{1}{2} \times \frac{1}{2} - 8\frac{7}{8}$

Storage Tray

- G Sides (2) $\frac{1}{2} \times 2 - 25$
- H Ends (2) $\frac{1}{2} \times 2 - 9\frac{3}{8}$

- I Dividers (2) $\frac{1}{2} \times 2 - 9\frac{3}{8}$
- J Center Bottom (1) $9\frac{1}{8} \times 14\frac{1}{4} - \frac{1}{8}$ Masonite
- K End Bottoms (2) $9\frac{1}{8} \times 4\frac{3}{4} - \frac{1}{8}$ Masonite
- L Tray Dividers (15) $\frac{1}{8}$ Masonite*

Removable Tray

- M Sides (2) $\frac{1}{2} \times 3 - 13\frac{15}{16}$
- N Ends (2) $\frac{1}{2} \times 3 - 9\frac{3}{8}$
- O Bottom (1) $9\frac{1}{8} \times 13\frac{3}{16} - \frac{1}{8}$ Masonite
- P Handle (1) $\frac{3}{4} \times 5 - 12\frac{15}{16}$

* size of divider varies, see text

$\frac{1}{2} \times 6\frac{1}{2} - 80"$ (3.6 Sq. Ft.)



$\frac{1}{2} \times 6\frac{1}{2} - 80"$ (3.6 Sq. Ft.)



NOTE: ALSO NEED $5\frac{1}{2} \times 13"$ PIECE OF $\frac{3}{4}$ "-THICK STOCK FOR HANDLE (P)

The Case

To join the parts of the Carry-All together, I used a joint that I call a hidden groove joint. Basically, this is a tongue and dado joint that's cut in a way to hide the groove for the bottom of the case, see box below.

To cut this joint, first cut shallow dados in the *side blanks* (A,G) at four locations shown in Fig. 1. To complete this part of the joint, cut kerfs along the shoulders of each dado. (Note the positions of the kerfs in Fig. 1a.)

Finally, cut tongues on the edges of the *ends* (B,H) and *dividers* (C,I) to fit the kerfs, see Fig. 1a.

CASE PIECES. Now rip the case sides, ends, and dividers so they're 6" high, and set aside the "waste" off the bottom for the storage tray, see Fig. 1.

Next, cut the grooves for the bottoms, see Fig. 2.

BOTTOMS. The *center bottom* (D) and two *end bottoms* (E) are cut from 1/8"-thick Masonite to fit in the grooves, see Fig. 2a. Finally, glue-up the case.

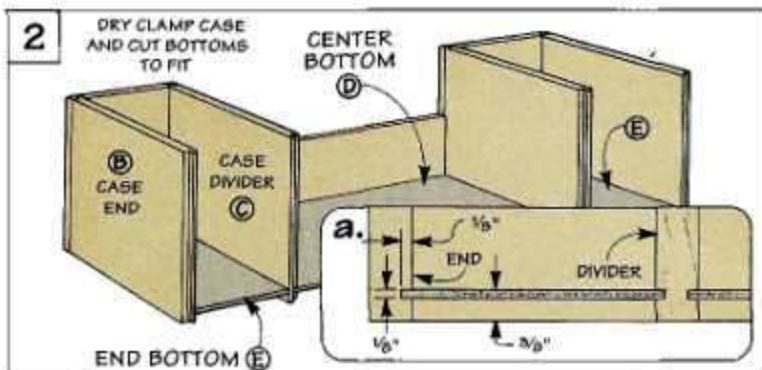
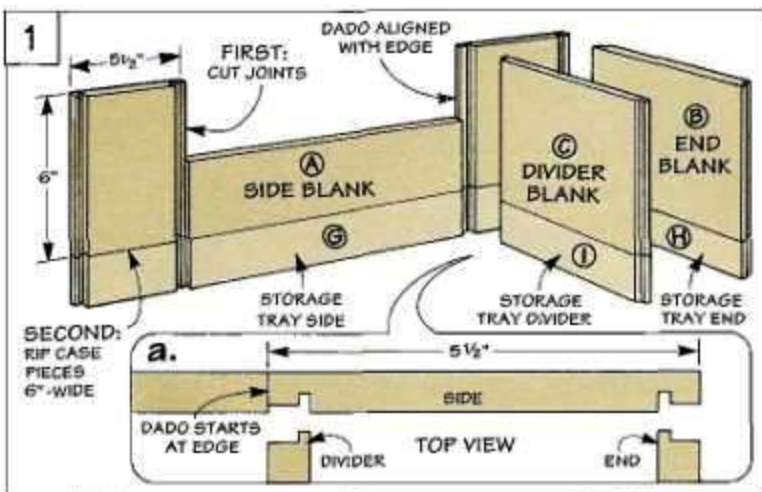

Hidden Groove Joint



I call this a Hidden Groove Joint, but it's just a variation of a tongue and dado joint. The idea is to cut the joint so it hides the groove for the bottom of the case.

If the joint weren't cut this way, the groove for the bottom would come through on the end of the side piece, and you'd have to "plug" this hole. This variation on the joint eliminates that problem.

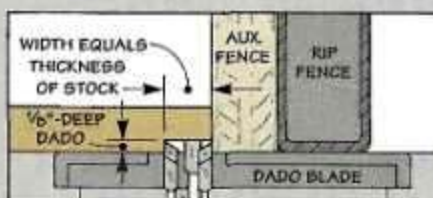

Step 1: Start by cutting a 1/8"-deep rabbet on side piece so width matches the thickness of the end piece.

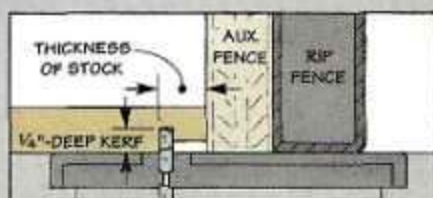

Step 2: Use the rip fence as a stop to cut a 1/4"-deep kerf right along the shoulder of the rabbet.

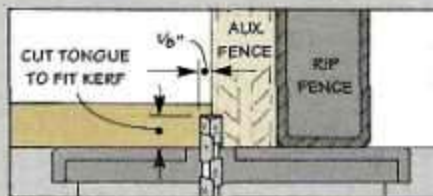

Step 3: Use a dado blade to cut a rabbet on the end piece, leaving a tongue that fits the kerf.

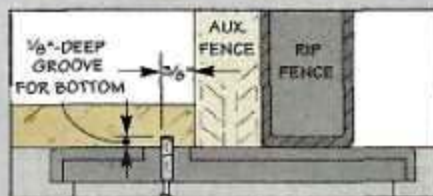

Step 4: Finally, cut a 1/8"-deep groove near the bottom edge of each piece to accept the bottom.

Storage Tray

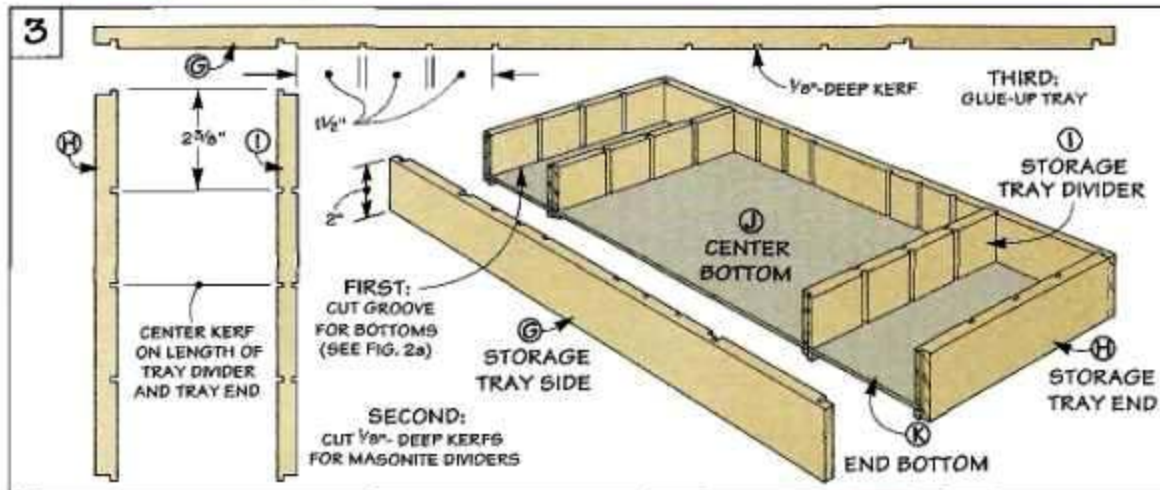

Now with the case complete, work can begin on the storage tray. All of the basic pieces for the tray are already cut (they're the cut-offs left over from ripping the case pieces to final width).

BOTTOMS. The only other pieces needed are the tray bottoms. But before cutting the bottoms, I cut grooves for the bottoms in all the tray pieces (G, H, I), refer to see Figs. 2a and 3.

After the grooves are cut, dry-clamp the tray together. Then, measure the inside dimensions (adding $\frac{1}{4}$ " to cut the center bottom (J) and two end bottoms (K) to size from $\frac{1}{8}$ "-thick Masonite.

SLOTS. The only additional step you need to do before assembling the tray is to cut slots for the tray dividers (L). These dividers allow you to separate the tray into small sections.

To allow for a variety of divider combinations, I cut a series of $\frac{1}{8}$ "-deep slots (kerfs) on the tray sides and ends, see Fig. 3. After the kerfs are cut, glue up the storage tray.

DIVIDERS. When the glue is dry, the tray dividers (L) can be cut from $\frac{1}{8}$ "-thick Masonite to fit the tray. There are three different lengths of dividers.

The shortest dividers fit in the slots in the ends of the tray, refer

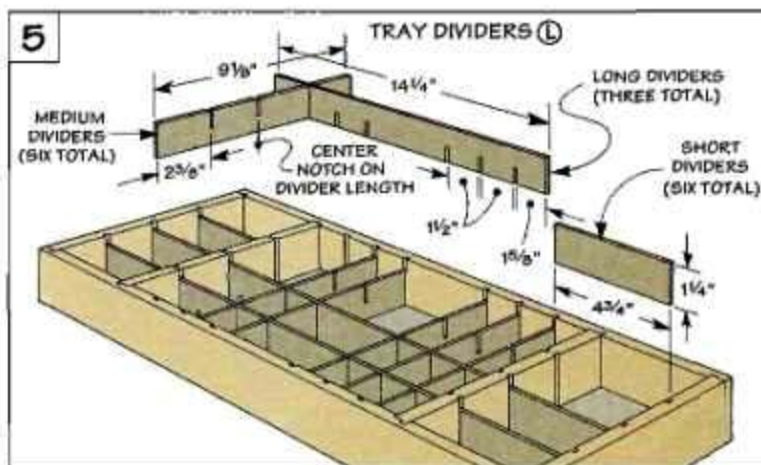
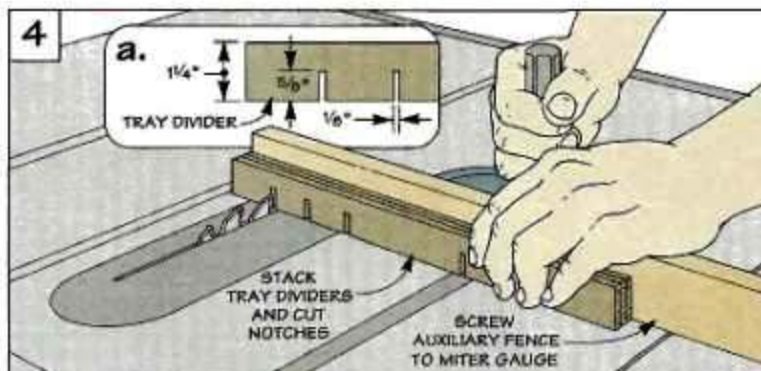

to Fig. 5. And the two longer dividers interlock to form a grid in the center of the tray.

Note: I cut all the dividers to a width of $1\frac{1}{4}$ " so they won't interfere with the cleats on the bottom of the case. (See page 15 for more on this.)

NOTCHES. After the dividers are cut to size, I cut the notches in the center dividers, see Fig. 4. Stack up like-sized dividers and cut the notches in three or four pieces at once. Note: To stabilize the cuts, screw an auxiliary fence to the miter gauge.

Removable Tray

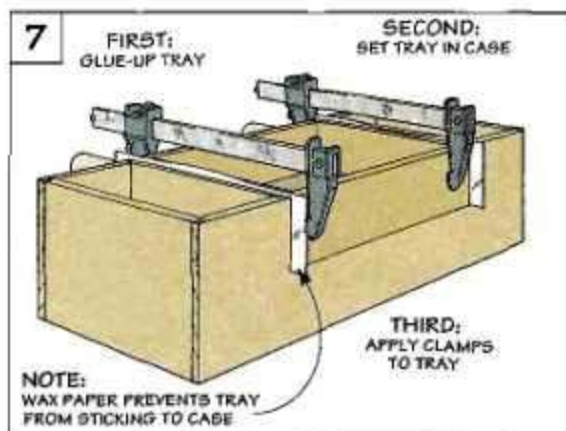
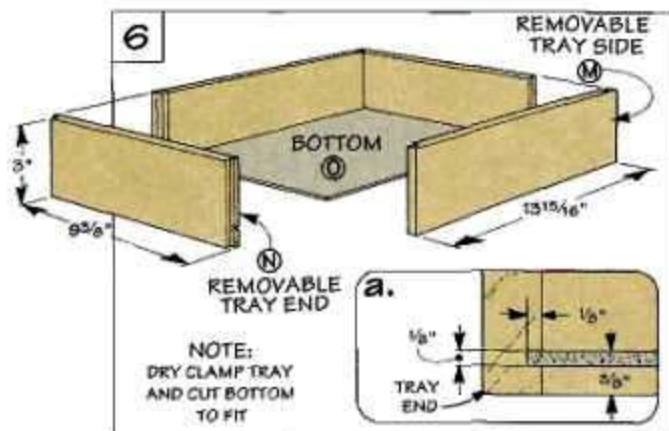

The Carry-All is designed with a removable tray that fits between the bins of the case. When the tray is locked into the case, the handle of the tray also serves as the handle for the Carry-All.

SIDES. To determine the size of tray, first measure the opening in the case, and subtract $1/16$ " from

the length (for clearance). Then cut two *removable tray sides* (M), see Fig. 6.

ENDS. The next step is to cut the ends to fit. Here again I used the hidden groove joint. So the length of the *removable tray ends* (N), is the same as the length of the case ends (B) ($9\frac{3}{8}$ ").

HIDDEN GROOVE JOINT. With the tray pieces cut to size, the next step is to join the pieces together. To do this, I used the same hidden groove joint that was used to join together the case and the storage tray, refer to page 12.

BOTTOM. Next cut the grooves for the bottom, and then cut a *bottom* (O) to size as you did for the case and storage tray.

To ensure the removable tray fits perfectly in the case, I applied glue to the tray, and immediately set the tray inside the case and applied clamps, see Fig. 7.

CHAMFER EDGES. After the glue is dry, rout or sand a slight chamfer on all the outside edges of the Carry-All.

HANDLE. With the edges chamfered, you can begin work on the handle, refer to Fig. 9.

To make the handle, start by cutting a $5\frac{1}{2}$ "-wide blank of $3/4$ "-thick stock to length to fit the *inside* length of the tray ($12\frac{15}{16}$ ", in my case). Then lay out and cut the *handle* (P) to shape, see Fig. 8.

To make the handle more comfortable to hold, I softened the edges with a $1/4$ " round-over bit (on the router table), see Fig. 9a. Note: Don't round over the outside ends of the handle.

Finally, drill a pair of countersunk pilot holes through each end of the tray and screw the handle in place, see Fig. 9.

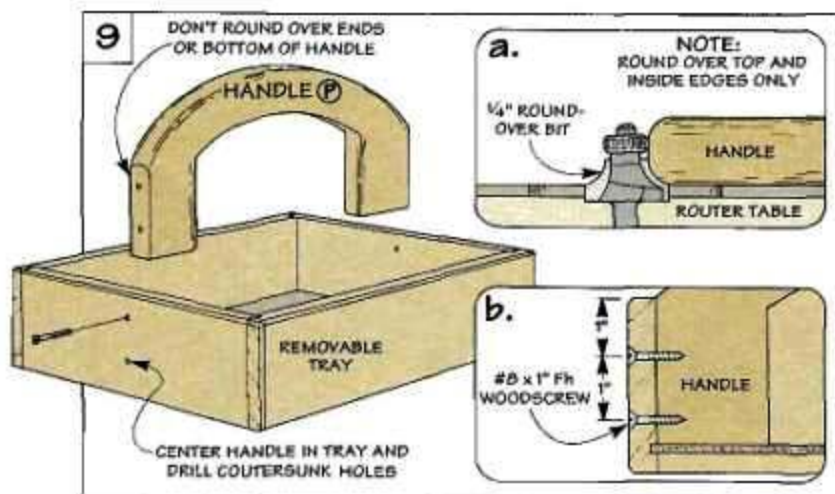
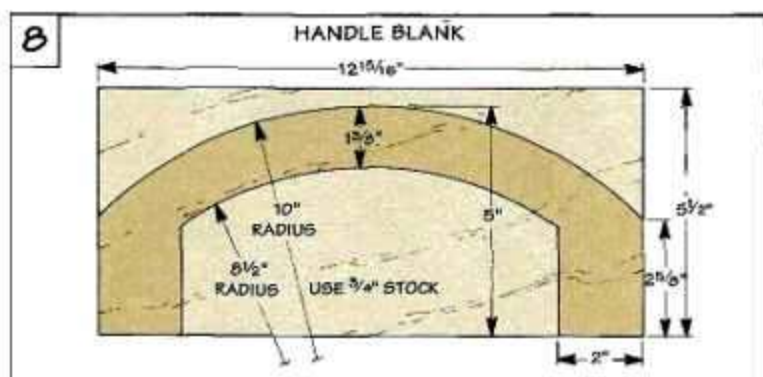

Assembly

The three sections of the Carry-All are held together with two pairs of catches. One pair "locks" the removable tray (with the handle) into the case. The other pair holds the lower storage tray onto the bottom of the case. (See page 31, for sources of catches.)

Before adding the catches, I glued cleats to the bottom of the removable tray, and to the bottom of the case, see Fig. 10. These cleats serve two purposes.

First, they align the trays with the case and prevent them from sliding around, refer to Fig. 10a.

Second, when the catches are installed, the "button" on the top catch protrudes down below the bottom edge of the removable tray, see Fig. 11. When you remove the tray and set it down, it would rock on the catch. But the cleats extend past the "buttons" to prevent this. (The same applies to the main case when the bottom tray is removed.)

CLEATS. Cut the four cleats (F) so they stick out $\frac{1}{4}$ ", see Fig. 10. Then glue two cleats to the removable tray, and two to the case.

CATCHES AND FINISH. Before adding the catches, I applied two coats of satin polyurethane. Then screw a pair of catches to hold on the removable tray, and another pair to hold the bottom tray.

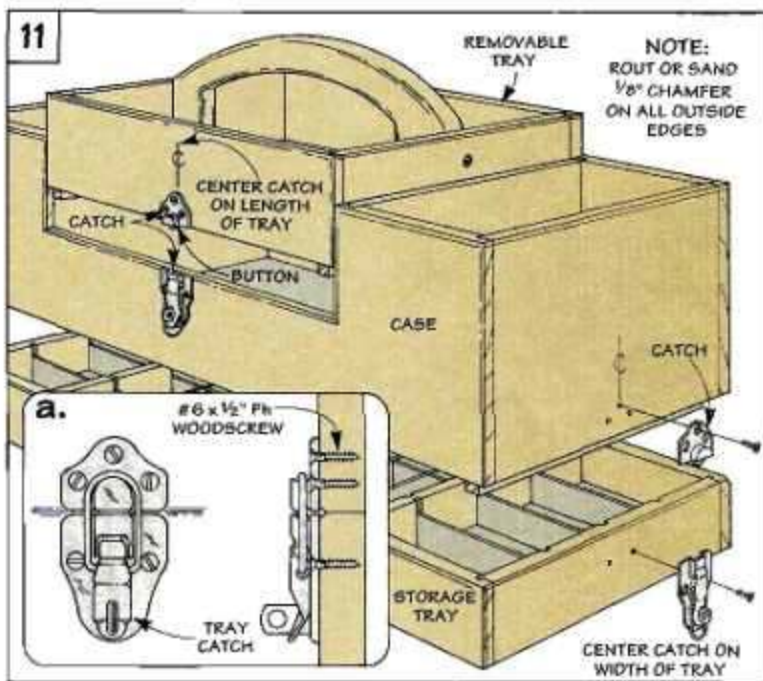
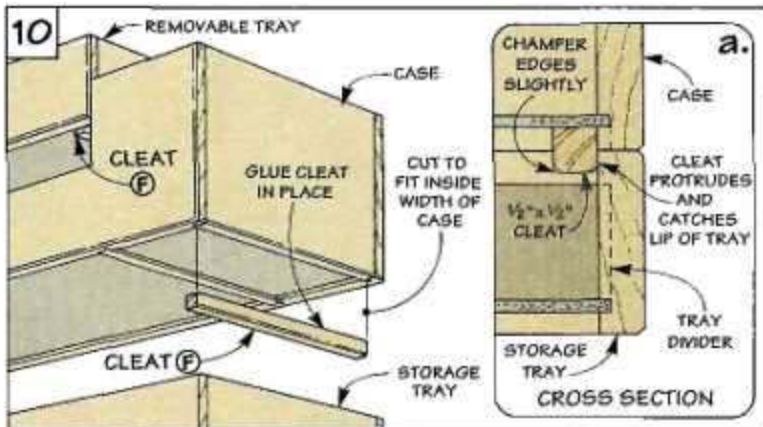

Storage Tray Options

▼ The center section of the storage tray can be divided to hold chisels and small tools.



Interlocking ► the center dividers of the storage tray provides an ideal area for storing hardware, screws, and bolts.



Plate Joinery

Three quick steps to tight joints. Cut one slot, cut another, and glue in a biscuit.

We've had a plate joiner in our shop for several years now. The guys borrow it for "production" jobs, like building their own kitchen cabinets.

But a plate joiner is more than a production tool. Many projects can be assembled using just one joint — a plate joint.

Basically, a plate joint consists of cutting two slots and gluing a compressed wood plate, or "biscuit" into these slots, see Fig. 1. On contact with the water in the glue, the biscuit swells against the faces of the slots, locking the joint in place.

ADVANTAGES

In addition to being a strong joint, plate joints also have a number of other advantages.

SPEED. First of all, cutting a plate joint is fast. All you have to do is butt the pieces together and mark across the joint, see Fig. 2. Then to cut the slots, align the centerline on the plate joiner with the layout line and just push the joiner into the workpiece, see Fig. 2a.

ACCURACY. But the biggest advantage of a plate joint is a built-in "fudge factor." To allow

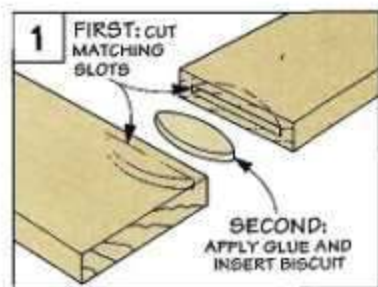

for the expansion of the biscuit, the slots are cut slightly longer than the biscuit, see Fig. 3a. Unlike dowel holes that have to line up perfectly, the extra side-to-side play lets you slide the pieces into alignment, see Fig. 3.

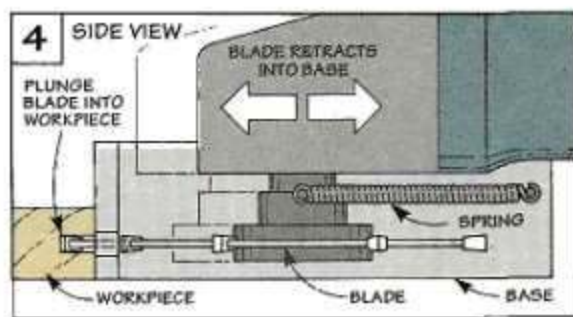
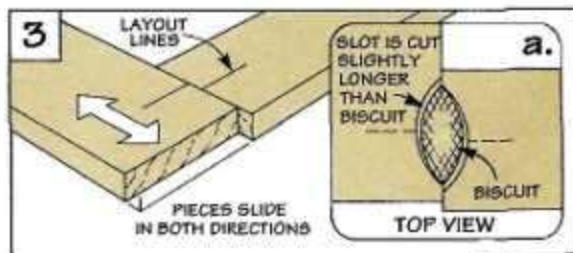
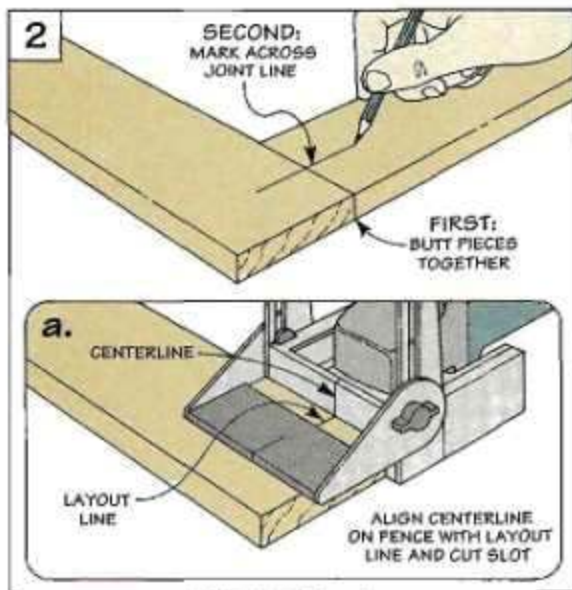

PLATE JOINER

The only problem with plate joinery is you need a special tool — a plate joiner. Basically, the joiner is a plunge-cutting circular saw with a horizontally mounted 4" blade, refer to Fig. 4.

SPRING-LOADED BASE. The blade is enclosed in a spring-loaded base. When the base is pushed against a workpiece, the blade projects through an opening in the base and cuts a slot.

When you pull the joiner away from the workpiece, the springs retract and the blade slips back into the base.

DEPTH ADJUSTMENT. The depth of the slot is controlled by presetting a depth stop. Plate joiners cut to three depths that correspond to three biscuit sizes, see Figs. 5 and 5a. There's also a micro-adjuster to fine-tune the depth of the slot.

FENCE. But the key to a plate joiner is how the slot is positioned on the workpiece. To position a slot, the height and angle of the fence is adjusted.

HEIGHT. For most cuts, the fence rests on top of the workpiece. Raising or lowering the fence positions the slot up or down, see Fig. 6.

ANGLE. Both the height and angle of the fence need to be ad-

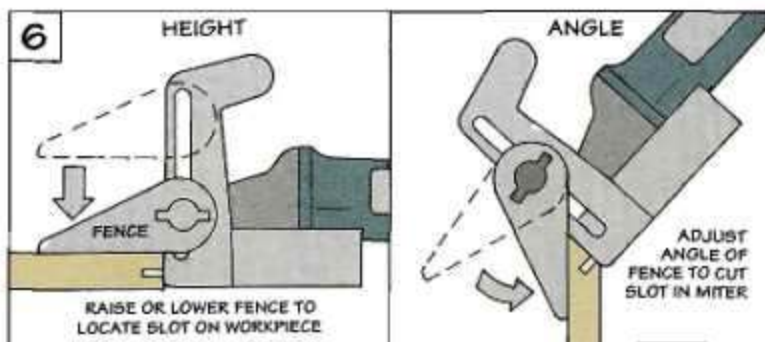
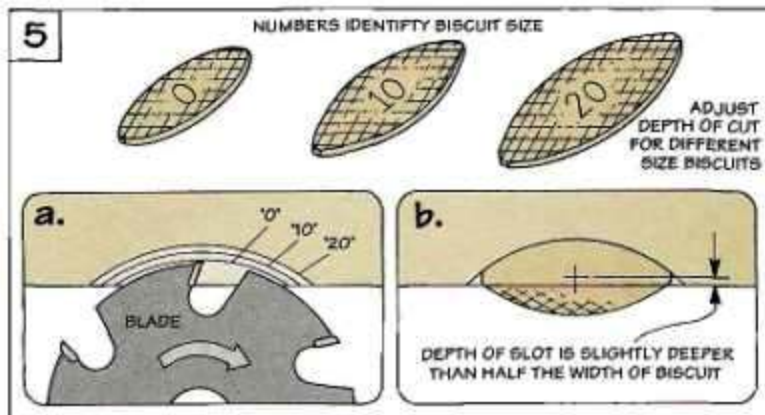

justed for mitered cuts, see Fig. 6. To adjust the angle, some joiners have a tilt-angle fence while others use a fixed-angle system. (For more on this, see page 20.)

LIMITATIONS

The thing you have to be careful about is getting "biscuit happy." There are times when a plate joint just won't work.

WIDTH OF STOCK. One of those times is when cutting slots in the end of a narrow board. To keep the blade from cutting into the edge of the workpiece, the workpiece must be wider than the slot length, see Fig. 7.

Even the smallest biscuit requires a slot $2\frac{1}{8}$ " long. This means the workpiece has to be at least $2\frac{1}{4}$ " wide to accept the slot.

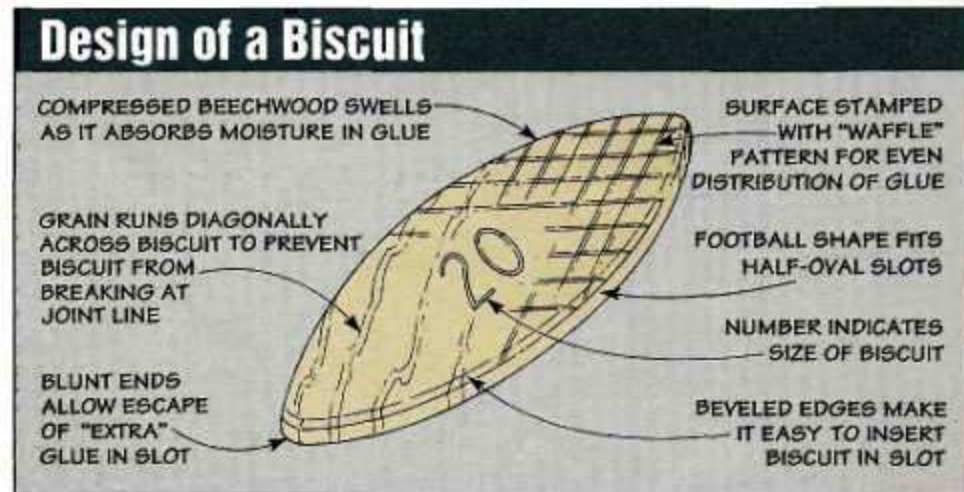
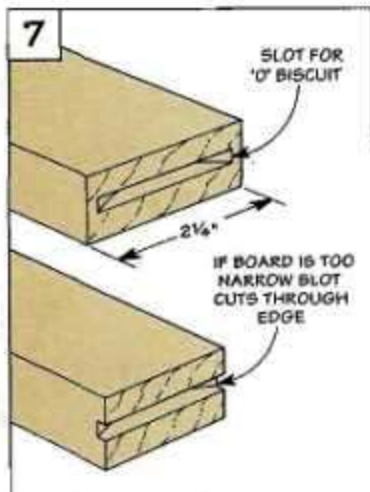

Making Plate Joints

All plate joints start out as butt joints. The only difference with a plate joint is that slots are cut in both pieces, then biscuits are added.

Face-Frame Joint

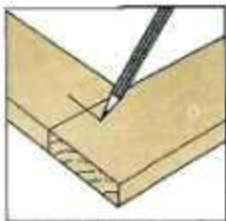

■ To join the corners of a frame, I use a face-frame joint. With this joint, slots are cut in the *end* grain of one piece, and the *edge* grain of another, see photo.

To do this, align the pieces and mark across the faces of the joint, see box at left. Then adjust the

fence height to center the blade on the thickness of the pieces.

Now, hold the fence tightly against the marked face of each piece, and cut a slot centered on the marks, see Figs. 1 and 2. To assemble, spread glue in the slot, insert a biscuit, and clamp.

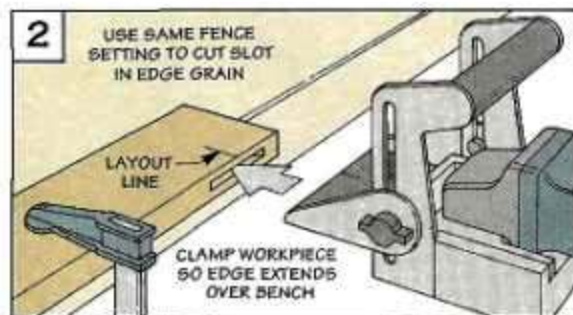
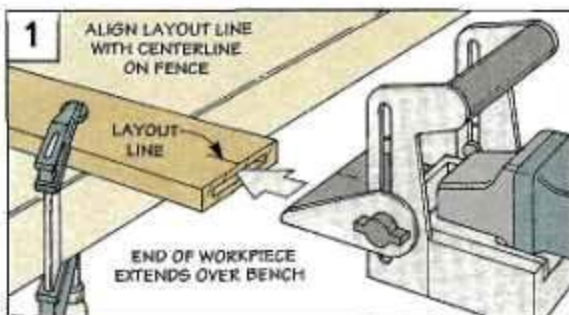

Corner Joint

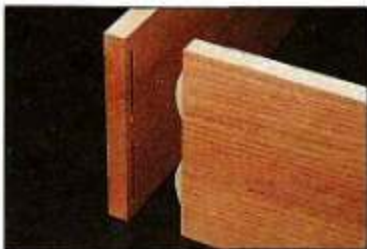
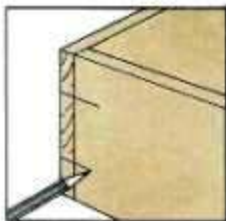

■ The only difference between a corner joint and a face frame joint is that slots are cut in the *end* grain of one piece and the *face* grain of the other, see photo.

Here again the pieces are held together and marked across the joint line, see box at left. Then

adjust the fence, and cut the end grain slots first, see Fig. 1.

Next, cut the slots in the face grain of the other board. To prevent the fence from tipping on the narrow end of this piece, I clamp on a backer board to support the fence, see Fig. 2.

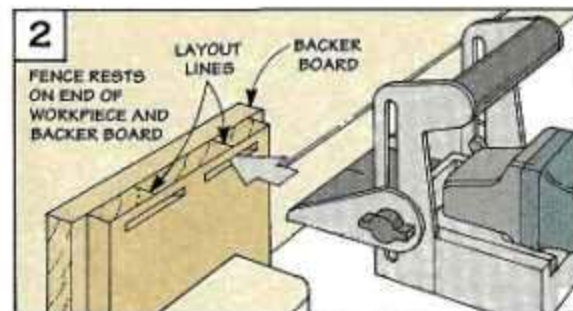
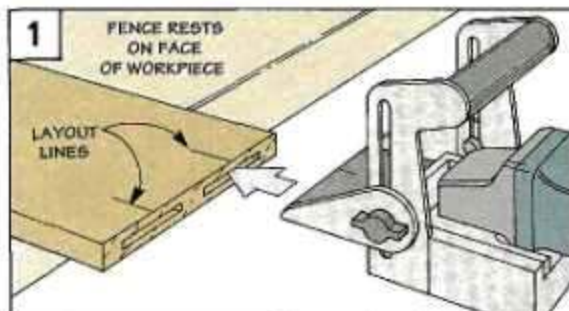

Miter Joint

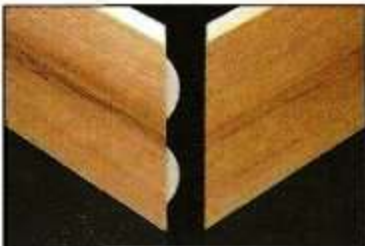

■ Using a biscuit to join the ends of two mitered pieces has a couple of advantages, see photo.

First, miters tend to slip out of alignment as you clamp them together. The biscuits prevent the pieces from shifting when the clamps are tightened.

Second, since the ends of the miter are primarily end grain, the biscuits help strengthen the joint by “locking” the pieces together.

To make the plate joint on mitered pieces, align the workpieces and make a mark across the joint line, see box at right.

Then, if possible, clamp each piece in a vise with the miter up, see drawing at left. (If the board is too long, clamp it to the bench so the mitered end extends over the edge of the bench.)

Next, adjust the angle of the fence to match the miter, and set the depth stop. To keep from cutting slots through to the outside face of the workpiece, position the fence so the slot is closer to the inside corner of the miter, see drawing at left.

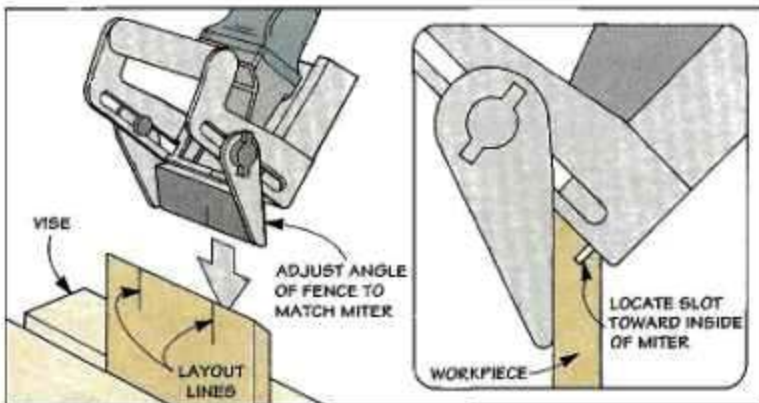
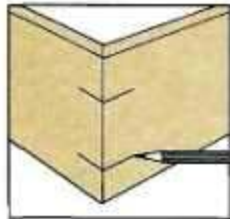

T-Joint

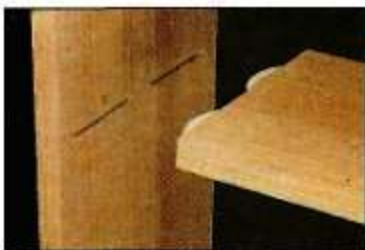

■ Like the corner joint, a T-joint requires cutting slots in the *end* grain of one piece and the *face* grain of another, see photo. For

example, when joining a shelf to the side of a cabinet.

The problem is the fence on the plate joiner can't be adjusted (it's actually in the way) for cutting the slots in the middle of the upright piece.

The solution is to tilt the fence out of the way (or remove it), and index the slots off the base of the plate joiner, see Fig. 1.

As before, align the pieces and mark the joint lines, see box at

right. Also, draw a line where the bottom of the shelf will be.

To cut the slots you use the two workpieces to align the plate joiner. To do this, clamp the pieces together with the shelf on the marked line, see Fig. 1a.

Now slide the joiner across the bottom piece to cut the slots in the end of the shelf, see Fig. 1. Then use the end of the shelf to guide the joiner to cut slots in the face grain, see Fig. 2.

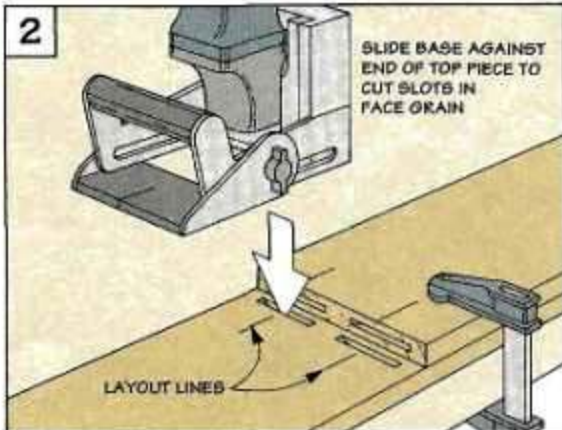
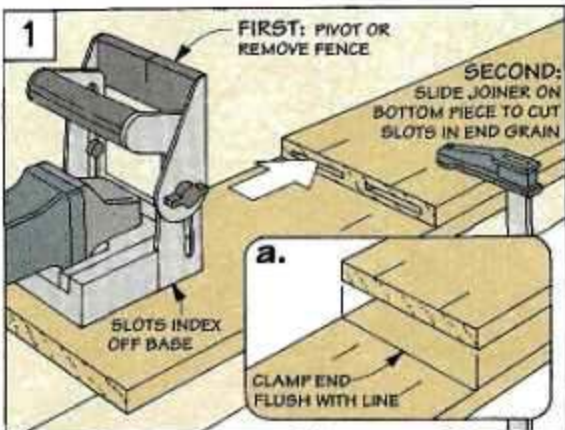
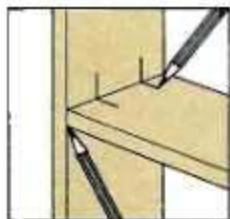

Plate Joiners



FREUD

RYOBI

SKIL

PORTER CABLE

I bought a Porter Cable plate joiner for the shop a few years back. At that time, it was the only joiner in the \$150-\$225 price range. Since then several other companies have come out with plate joiners priced in this range. So I decided to give them a try.

I purchased four plate, or biscuit joiners: a Ryobi JM-100, a new Porter Cable 555, a Freud JS-100, and a Skil 1605. The most expensive joiner was the Ryobi at around \$215, the least expensive was the Skil at about \$130.

Basically, these joiners all cut a 90° slot (in the end or edge of a workpiece) the same way. In fact, with the exception of the Porter

Cable's unique handle design, they even look alike, see photo. But there are clear differences when it comes to adjusting the fences to make an angled cut.

FIXED-ANGLE. The Skil, Porter Cable, and the Freud all have fixed-angle fences. This means you can only make two different cuts—a 90° or 45° cut. To change the angle, you have to remove the fence and flip it over, see drawings below left and center.

This is fairly easy with the Freud. The fence slides off by loosening a couple of wing nuts. But it's more of a hassle with the Porter Cable and Skil. To reverse these fences, you need to remove

two Allen screws (and washers) that hold the fence to the base.

TILT-ANGLE. Ryobi seems to have solved the problem with a tilt-angle fence, see drawing below right. This fence adjusts to virtually any angle without ever having to remove it.

MITER CUTS. There's one other key difference between these fences—the way they line up on a workpiece to cut slots in a miter.

The Porter Cable and the Ryobi "trap" the long point of the miter between the fence and the base, refer to Fig. 1. In this position, it feels like the joiners are locked in place.

RIBS. The Freud and Skil join-

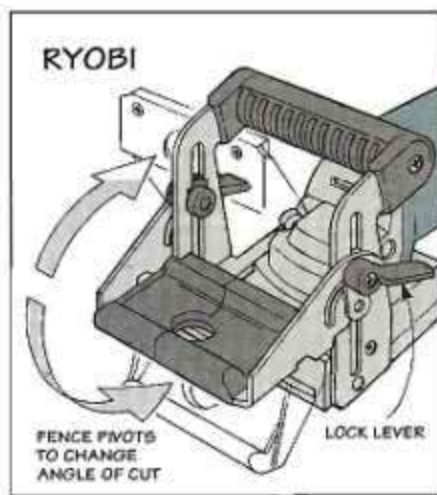
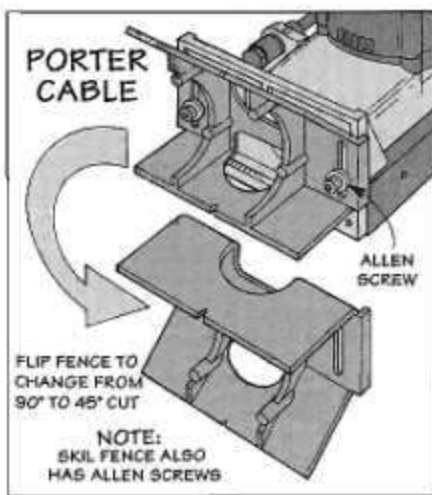
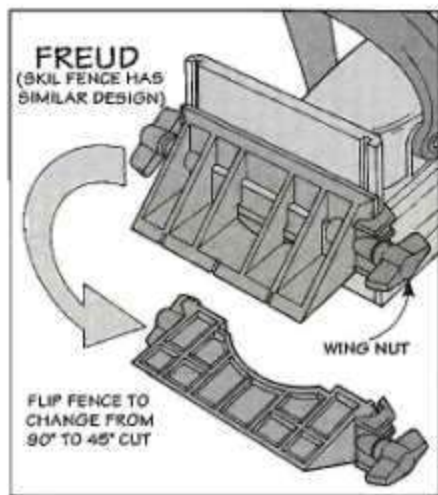

ers use a different system to cut a slot in a miter. Their fences have 45° "ribs" that rest on the inside face of the board, see Fig. 2.

At first it feels like these joiners can "ride up" the face of the miter. But if you position the base tight against the miter, they do make accurate cuts.

T-JOINTS. Another joint that requires a different setup is a T-joint. On most joiners, when making a plunge cut into face grain, the fence gets in the way. (For more on this, see page 19.) The only joiner I tested that can make this cut without removing the fence is the Ryobi, see Fig. 3.

OTHER FEATURES

Although the fence is probably the most important part of a plate joiner, there are several other features worth considering.

CHANGING BLADES. There's no need to change the carbide blade on a plate joiner very often. But when you do, it should be as simple as possible.

Removing the blade on the Ryobi is simple. Just remove a plate in the base, press the spindle lock, and loosen the arbor nut with an Allen wrench. The blade slides out the front of the base.

Changing the blade on the other joiners isn't as easy. You'll need a tray to hold all the parts that have to be removed. Even when you finally get to the blade, none of these joiners has a spindle lock button.

DUST BAG. Another feature to consider on these joiners is the

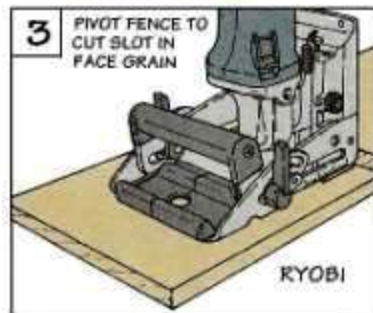
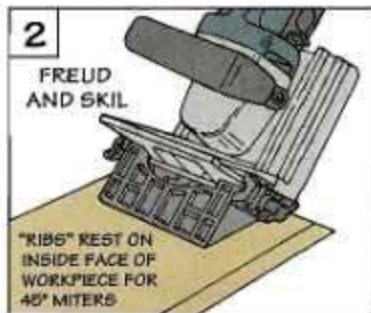
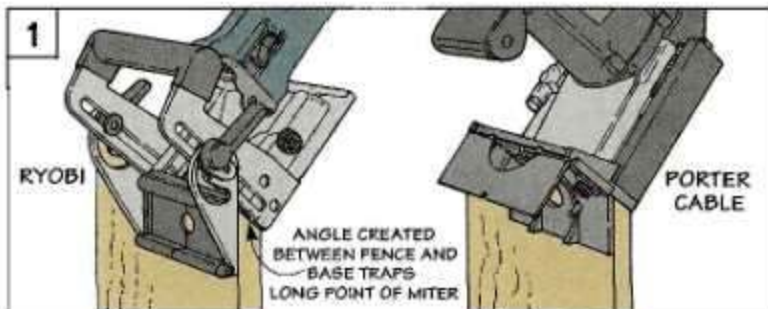

dust collection system. (Making plate joints creates a lot of chips.)

The Skil and Ryobi are the only two that come with a dust bag. The dust bag on the Skil works pretty well. But the Ryobi's is a bit of a mixed blessing.

The problem with the Ryobi is when the bag is attached, there's no room for your fingers to grip the handle near the front of the barrel—where the switch is. Also, the dust chute clogs up with chips when the bag is in place. As a result, I found myself not even using the dust bag.

HANDLE. Even without the dust bag attached, I have a hard time getting used to the barrel handles and the slide on/off switches on the Ryobi, Skil, and Freud joiners. I like the more fa-

miliar feel of the Porter Cable's D-handle with a trigger switch that's right at my fingertip.

Regardless of the shape of the handles, each of these joiners is fairly steady when making a cut. This is important because a joiner has a tendency to "walk" to the left due to the clockwise rotation of the blade.

PADS AND PINS. To keep the joiner in place, the Ryobi has a rubber pad screwed to the front of the base, see Fig. 4. I like this better than the Porter Cable and Freud joiners that use two spring loaded pins. Surprisingly, ridges molded into the plastic base of the Skil also prevent it from sliding.

CONCLUSIONS

I've cut a lot of plate joints with the Porter Cable over the years. And it's been a dependable tool. But after trying out all four joiners, I find myself leaning toward the Ryobi.

The biggest reason is the adjustable fence system. All it takes is one simple operation to adjust the height and angle of the Ryobi fence. In my opinion, that's worth the extra cost all by itself.

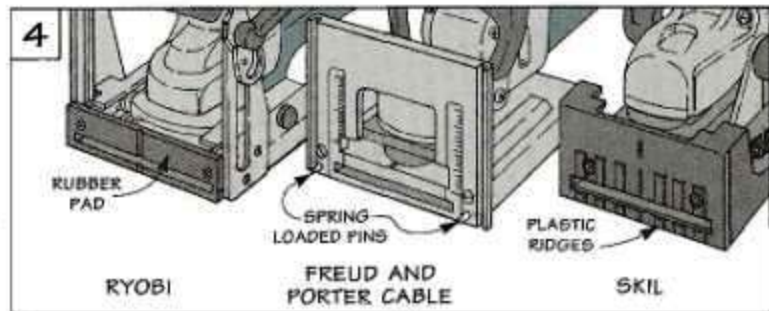

Clamping Station

Glue up panels and frames . . . and get them perfectly flat on this clamping table. It doubles as a working-height assembly table.



▶ "Cradles" keep the clamp heads upright, yet allow you to slide the clamps from side to side.

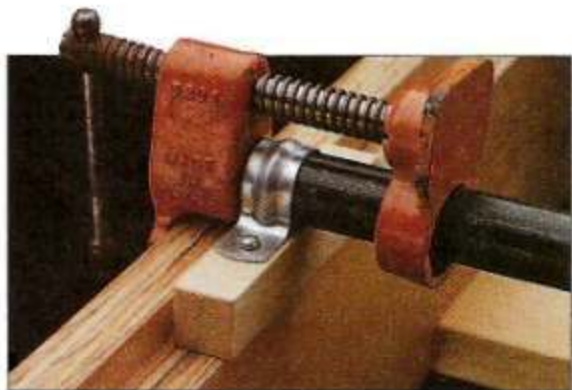

▶ By adding a plywood top, you can convert the clamping station into an assembly table.



▶ If space is limited, the table can be wall mounted to fold up when not being used.



Until recently, whenever I had to glue up a large panel or frame, I started by clearing out a large area on the shop floor. It was the only flat surface in the shop that wasn't already piled high with tools or half-finished projects.

But bending over to get the boards aligned and clamps tightened got to be a pain in the back. It was time to design a working-height clamping station.

GLUE-UP TABLE. This table provides a flat surface for gluing up panels and frames, see photo above. (For a source of clamps, refer to page 31.) If floor space is too limited for the free-standing version, the table can be hinged to the wall, see bottom left photo.

ASSEMBLY AREA. By adding a plywood top, the table converts to a good-sized work surface or assembly area, see center left photo. And when you're not gluing boards together, the pipe clamps can be stored inside the table.

TABLE DESIGN. Basically, the clamping station is a simple wood frame with four legs. But there are a couple of features that separate it from a typical glue-up table.

CLAMP CRADLES. First, the ends of each pipe clamp are attached to cradles that hold the clamp heads upright, so there's no fumbling around when you're ready to start gluing, see top left photo. The cradles also slide from side to side in rabbets built into the table frame.

SUPPORT RAILS. Another feature of this clamping station is the support rails (see page 24). These rails raise the workpiece off the pipe clamps just enough so the edge of the boards is centered on the clamp screws. This gives a direct line of pressure from the clamps so the panel is glued up flat.

The Top Frame

The heart of the clamping station is the top frame. I made it wide enough to hold 36"-long pipe clamps, and long enough to glue up a 48"-long panel.

The top frame actually consists of two frames, one inside the other. This creates a rabbet around the inside edge, refer to Fig. 2a. This rabbet holds the cradles and the support rails.

Design Note: I used 3/4" plywood to build both frames. If these frames were made out of solid wood, they could warp and transfer a twist to the workpiece.

INSIDE FRAME. To build the inside frame, cut the front, back, and side pieces to size, see Fig. 1. Then glue and screw these pieces together. To keep the table from racking, I added two cleats across the center.

OUTSIDE FRAME. To create the rabbet, cut the outside frame pieces 1/2" wider than the inside frame, see Fig. 2. Then glue and screw these four pieces around the inside frame.

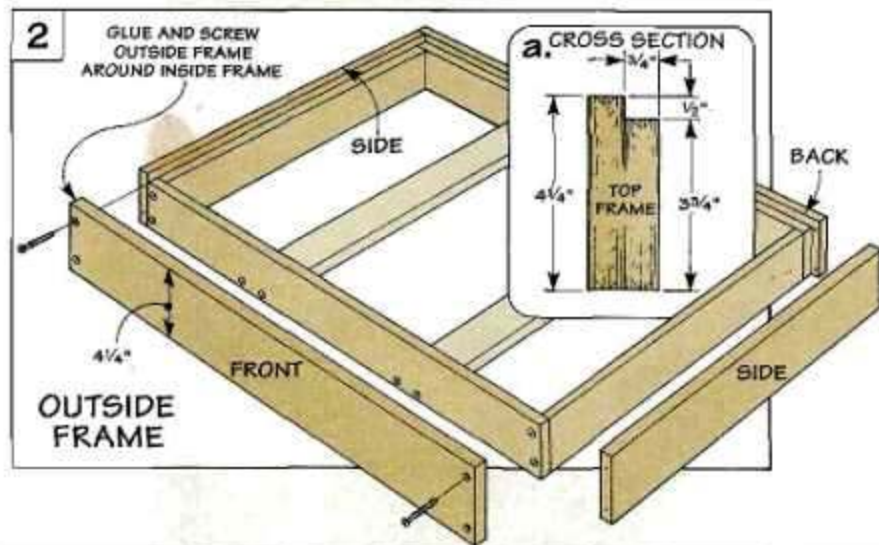
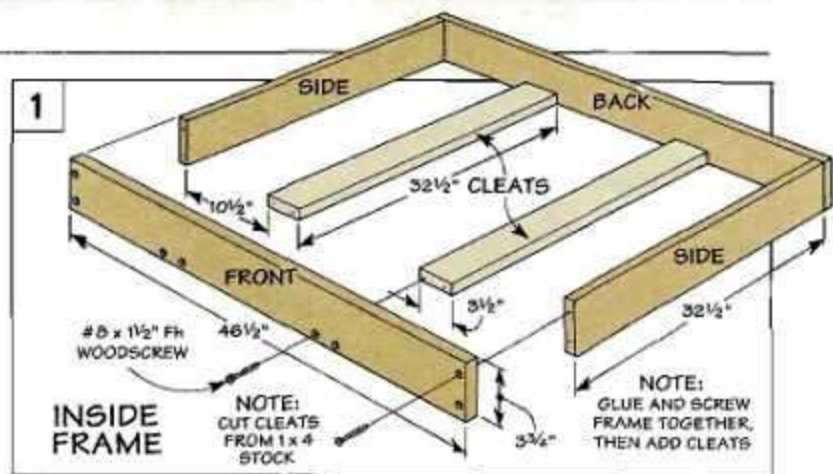

Cradles

One of the most frustrating things about using pipe clamps is that the clamp heads always seem to fall over just when you're ready to tighten the screws.

To hold the clamp heads upright, I made two cradles for each pipe clamp. The cradles are just

wood blocks with electrical conduit holders screwed to them, see Fig. 3. The blocks can be any size, as long as they're tall enough so the clamp heads clear the top edge of the frame, see Fig. 4.

The cradles rest in the rabbet on the inside edge of the top

frame and allow you to slide the clamps from side to side.

TIP: You don't have to use the whole clamping station to take advantage of the cradles. They work great on any flat surface to hold the clamp heads upright as you're clamping up a panel.

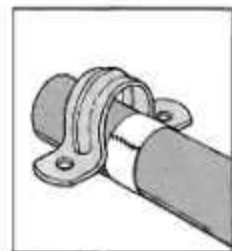
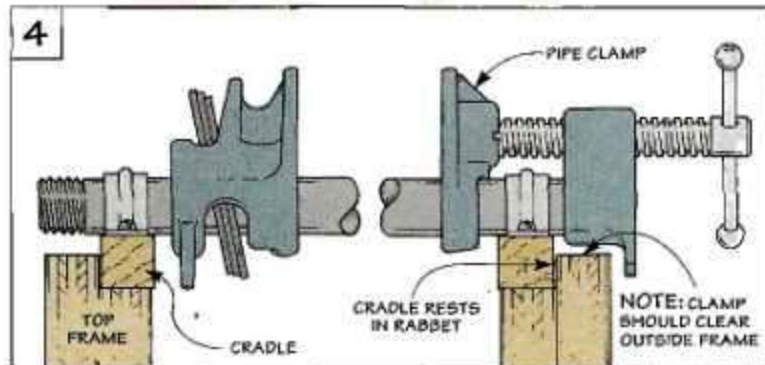
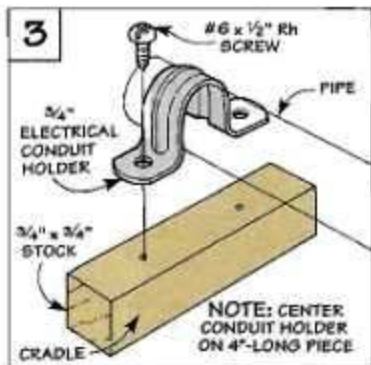

If the pipe turns inside the conduit holder, wrap a strip of masking tape around the end of each pipe.

Support Rails

One unique feature of this clamping station is the support rails. The purpose of these rails is to raise the boards so they're centered on the clamp screw.

Why not just lay the boards directly on the pipes? As you tighten the screws, the boards tend to bow up in the middle.

This bowing can be caused by a number of things, from a twist in one of the boards to edges that aren't square. But more often than not, the problem is caused by the clamps themselves.

PROBLEM. As a pipe clamp is tightened, the pipe starts to bow up in the middle. If the boards are sitting on the pipe, they will "copy" this same bow.

SOLUTION. How do you prevent this from happening? There's really nothing you can do to prevent the pipe from bowing. The problem is "built into" the clamps. But you can raise the workpiece off the pipes.

SUPPORT RAILS. That's where

the support rails come in. The rails elevate the boards above the pipes so the bow in the pipe can't transfer to the workpiece.

Making the support rails is easy. Just glue up two pieces of $\frac{3}{4}$ " plywood, and cut this blank to length to fit between the rabbets in the top frame, see Fig. 5.

The only tricky part is figuring out how tall (wide) to make the rails so they raise the stock to the center of the clamp screw.

DETERMINE WIDTH. This requires a little arithmetic. Start by measuring the distance from the bottom of the rabbet to the center of the clamp screw ($2\frac{1}{4}$ " in my case). Then subtract half the thickness of the stock you'll be clamping up. (For example, for $\frac{3}{4}$ "-thick stock, subtract $\frac{3}{8}$ ".) Then rip the rails to this width ($1\frac{7}{8}$ "), see Figs. 5 and 6.

NOTCH. The same support rails can also be used for thicker stock, like $\frac{5}{4}$ ($1\frac{1}{16}$ "-thick) stock. But because of the extra thickness,

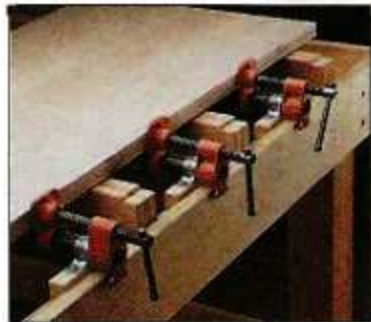

▲ Support rails raise the boards off pipes and center pressure on the thickness of your workpiece.

the rails need to be lowered.

To do this, cut a $\frac{3}{16}$ " notch on each end of the rails, see Fig. 7. Then just flip the rails over so the notch rests on the rabbet.

TIP. There's a side benefit of using the support rails. If the boards rest directly on the pipe, a chemical reaction occurs between the glue and the pipe which causes black marks. But using the rails raises the boards off the pipe to prevent this.

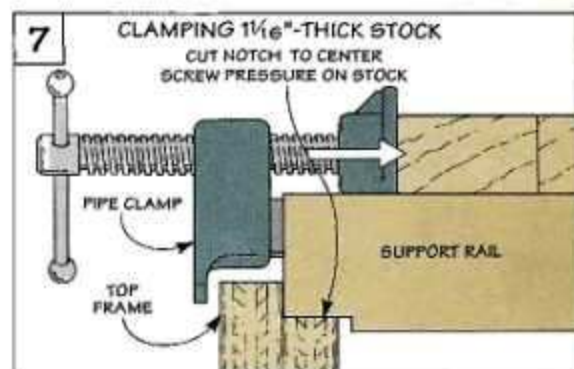
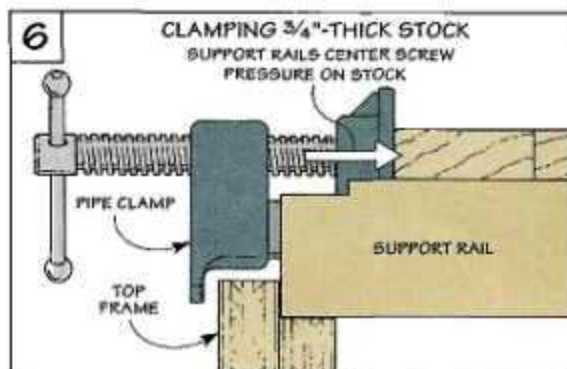
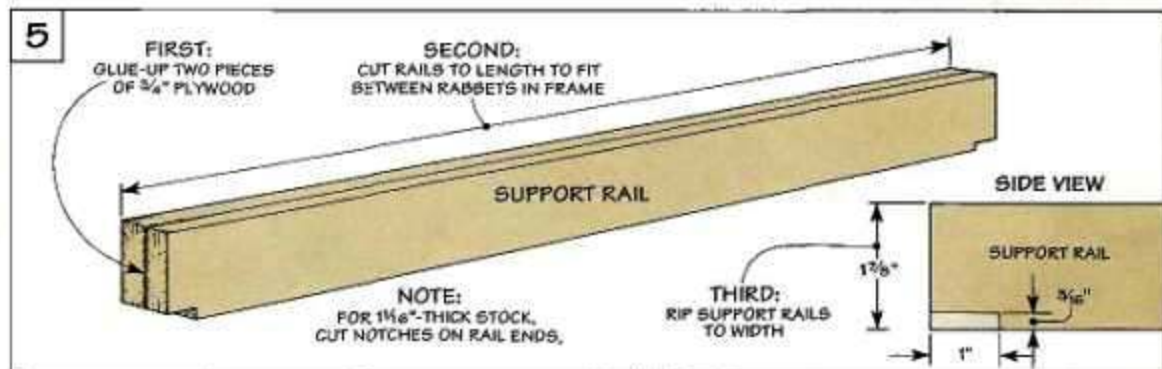

Legs and Table Top

To complete the clamping station, I added four legs. Each leg is made by gluing two lengths of 2x4's together, see Fig. 8.

I cut the legs 32" long. But you can adjust the length so the table height matches another work surface in your shop. Or, just find a comfortable working height and cut the legs to suit.

ATTACH LEGS. After the glue dries, clamp the legs to the frame so the top is flush with the bottom of the rabbet, see Fig. 8a. Then drill countersunk shank holes, and glue and screw the legs to the inside corners of the frame. For added strength, glue and screw 1x4 stretchers to the legs.

TABLE TOP. As an option, you can convert the clamping station into an assembly table. To do this, cut a piece of 1/2" plywood to fit in the rabbet on the top edge of the frame. To make it easier to lift out the top, drill a 1" finger hole near one edge.

FINISH. To keep glue from sticking to the support rails, you

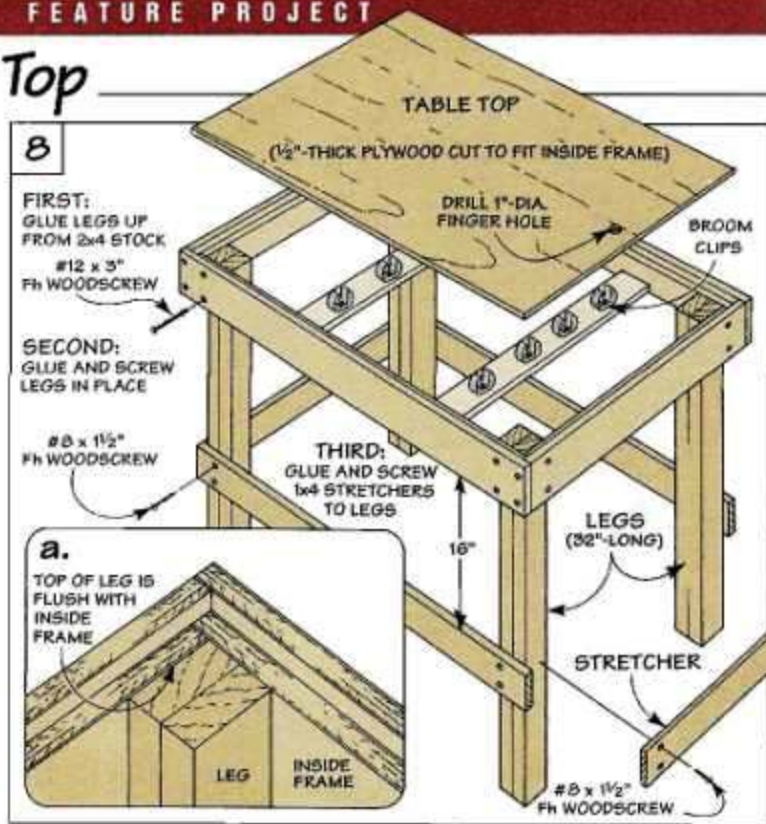

Shop Tip
Broom clips provide a great way to store your pipe clamps when they're not being used.

can place strips of wax paper along the top edge of the rails. Or, brush on several coats of polyurethane, and apply a couple of coats of paste wax.

BROOM CLIPS. Finally, I screwed broom clips to the cleats, see Fig. 8. This way I can store the clamps when they're not being used.

Fold-Up Version

If your floor space is limited (whose isn't?), this clamping station can be hinged to a wall to swing up out of the way when not in use. All this requires is a couple of simple modifications.

HINGE TABLE. First, one of the short ends of the top frame is hinged to a 2x4 cleat, that in turn is screwed to the wall, see detail a.

To hinge the table, first screw the cleat to the wall. Then mount the hinges between the table and the cleat, see detail a.

LEGS. The other modification is that there are only two legs. Each leg is made from a 32"-length of 2x4 that's bolted to the outside of the top frame. Just drill a 3/8"-dia. hole through the legs and frame and insert a 3/8" x 4" hex head bolt, see details b

and c. When the table is lifted, the legs pivot on the bolts and swing toward the wall. (For 32"-high legs, this requires a ceiling clearance of 81".)

Finally, screw a 1x4 stretcher to the legs. Then I added a hook and eye to store the clamping station up against the wall.

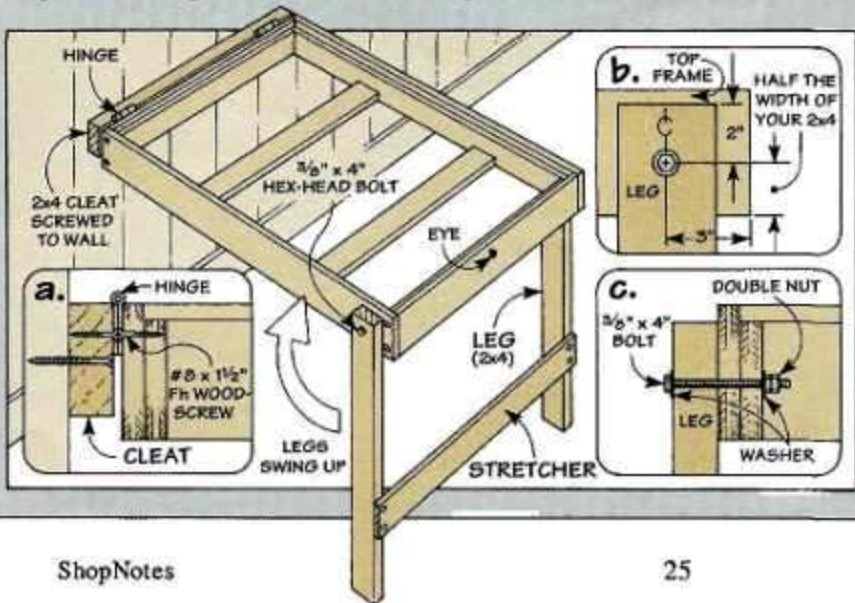

Shop Solutions

Drill Press Clamp

Occasionally I need to glue-up two small pieces of wood. But it's almost impossible to clamp the pieces together without the twisting action of the clamp causing them to shift out of alignment.

One solution is to use your drill press and a hex-head bolt as a clamp. This allows you to exert pressure in a vertical line — with no rotation whatsoever.

To do this, first align the workpieces and make a pencil mark across the joint line. Then, place

the pieces on the drill press table and position the bolt about 1" above the workpieces.

Next, apply glue and match up the pencil marks. Now turn the handle on the drill press to lower the head of the bolt so it presses tight against the workpieces, see drawing. Then tighten the depth adjustment to hold the bolt in place. This clamps the joint tight without twisting.

*Clifford B. Hicks
Brevard, NC*

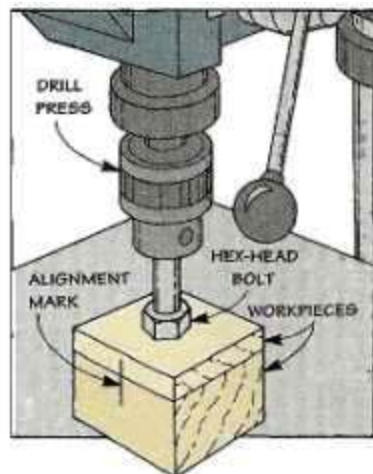

Scraper Holder



A hand scraper is a great tool for smoothing a workpiece. But keeping the scraper flexed can be tiring. And the friction from scraping can build up enough heat so it's uncomfortable to hold.

I eliminated both of these problems with this simple scraper holder, see photo. It's just a scrap of $\frac{3}{4}$ "-thick stock with a couple of screws to hold the scraper.

THUMBSCREW. To flex the scraper, I added a thumbscrew (available at hardware stores). It's threaded through the holder and pushes against the back of the scraper allowing you to adjust the amount of flex, see Fig. 1.

CUT BLANK. To make the scraper holder, start by cutting a blank 2" longer than the length of your scraper, see Fig. 1.

DRILL HOLES. Now lay your scraper flat on the holder and

center it from side-to-side, see Fig. 2. Now mark and drill a pilot hole for a screw at each end of the scraper.

The next step is to drill a hole centered on the holder slightly less than the diameter of your thumbscrew, see Fig. 2. (This way the thumbscrew will cut its own threads as it's screwed in.)

To assemble the holder, screw the scraper in place and thread the thumbscrew directly into the holder. Finally, adjust the thumbscrew for the desired amount of flex, see Fig. 1.

*Wes Boulton
Ft. Collins, CO*

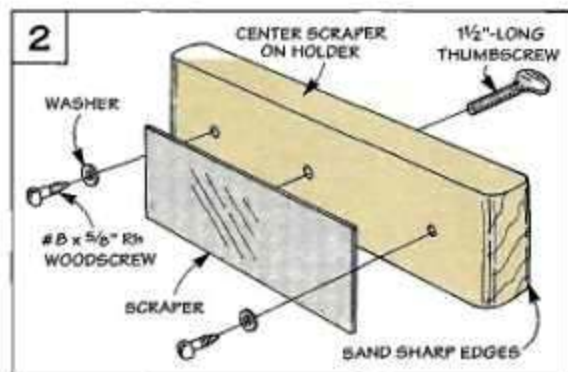
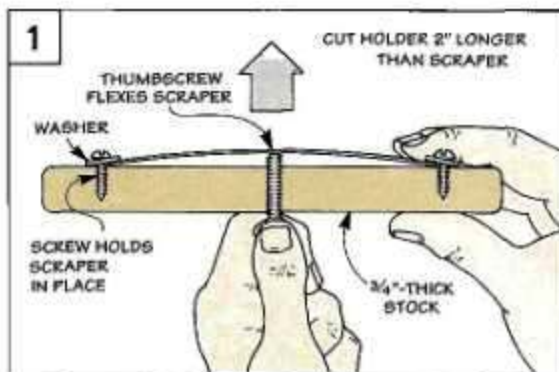

Shop-Made Bench Vise

Recently I needed to sand some long trim pieces for a project. I tried to use my bench vise to hold them, but it didn't support the ends of the trim. To solve this, I built a long vise that clamps on top of my bench, see Fig. 1.

The vise is just a 2x6 that's ripped in two to form the jaws of the vise. The clamping power comes from $\frac{5}{16}$ " threaded rods.

THREADED RODS. These rods run through the front jaw and are anchored into nuts set in "pockets" in the rear jaw, see Fig. 1b.

The length of the rods and the distance between them can be adjusted to fit your workpiece. (The longer the rods, the farther apart you'll be able to spread the jaws.)

Tightening wing nuts threaded on the end of the rods pinches the workpiece between the jaws.

CUT 2x6. To make the vise, start by cutting a 2x6 to length. Then locate the holes for the threaded rods and the nuts that hold them in place, see Fig. 2.

DRILL HOLES. Next, drill $\frac{3}{8}$ " holes for the rod. Then use a 1" spade (or forstner) bit to drill the "pockets" for the nuts. To keep these nuts from spinning when the wing nuts are tightened, set the depth so one face of the nut sits flat against the bottom of the "pocket," see Fig. 1a. After the holes are drilled, rip off the 2"-wide front jaw.

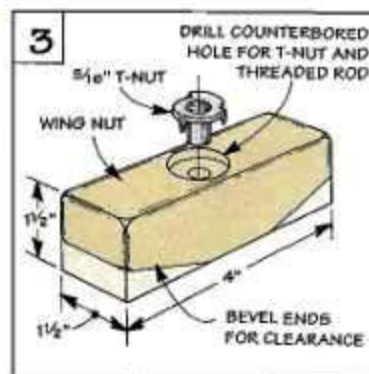
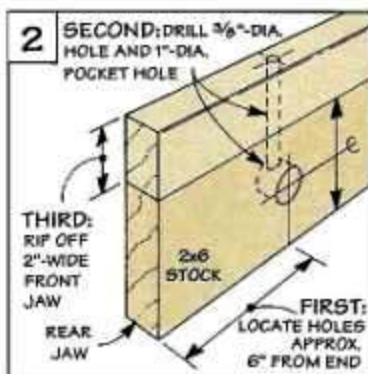
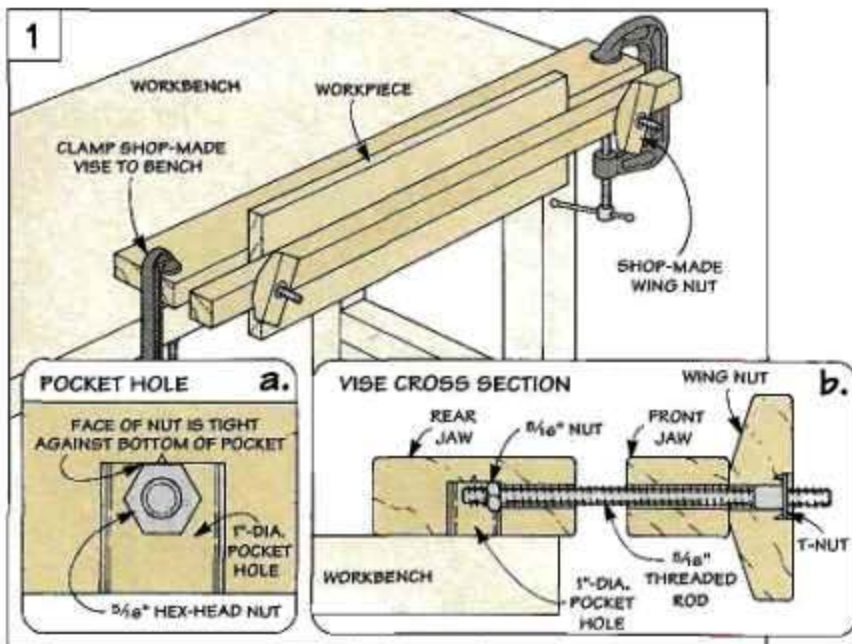

WING NUTS. I made my wing nuts from $1\frac{1}{2}$ "-thick scrap cut 4" long. Drill a hole for the threaded rod and counterbore it to accept

a T-nut. The opposite side is beveled for clearance.

Tom O'Sullivan
Fairfield Bay, AR

Manual Organizer



An easy way to keep shop manuals organized is to use a three-ring binder. The problem is some manuals don't have holes. (And you may not have a 3-hole punch.)

A visit to the local craft store will solve this problem. Just purchase several plastic Craft Book Holders, see photo. Now you can fit almost any size manual into a three-ring binder.

Send in Your Solutions

If you'd like to share original solutions to problems you've faced, send them to: *ShopNotes*, Attn: Shop Solutions, 2200 Grand Ave., Des Moines, IA 50312.

We'll pay up to \$200 depending on the published length. Send an explanation along with a photo or sketch. Include a daytime phone number so we can call you if we have questions.

Toggle Clamps

What's the secret to building better fixtures, or making quick work of a repetitive job?

Toggle clamps.

Let's face it, almost every woodworker likes to build jigs and fixtures. However, one of the difficult parts about most fixtures is figuring out how to hold the workpiece to it.

In most cases, this means using clamps — and that usually means struggling around the awkwardness of screw-type clamps.

A C-clamp, for example, requires two hands to hold it in position to tighten. As it's tightened, it can cause a workpiece to rotate out of alignment, and can be tightened too much or not enough.

TWO ADVANTAGES. That's why I've come to appreciate toggle clamps. After using toggle clamps on a number of fixtures, I've found they have two advantages over C-clamps.

First, since they're mounted to the fixture, you only need one hand free to lock them down. And second, when a toggle clamp is in the locked position, it exerts a *preset and consistent* amount of pressure on the workpiece.

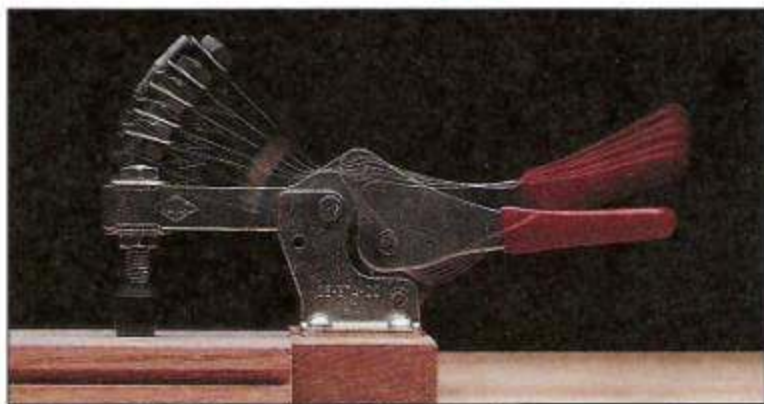

Toggle clamps don't screw down. Instead, the handle is a lever that "locks" at a preset position, see Fig. 1. It's that simple. (For mail-order sources, see Sources on page 31.)

LIMITATIONS. Basically, there are four types of toggle clamps: in-line, hold-down, pull type, and squeeze. The two most commonly used for woodworking fixtures are the in-line (see Fig. 1a) and hold-down (Fig. 1b).

Before you build a fixture, I'd suggest you have the toggle

clamp in hand. They have a limited amount of "throw," which limits their application.

ADJUSTMENT. So how do you adjust a toggle clamp to exert the correct amount of pressure?

First, the toggle clamp is positioned near the workpiece — usually so the spindle pad is only about 1" away.

Then to adjust the pressure, the spindle is threaded so you can fine-tune the position of the clamp pad to get the right amount of pressure.

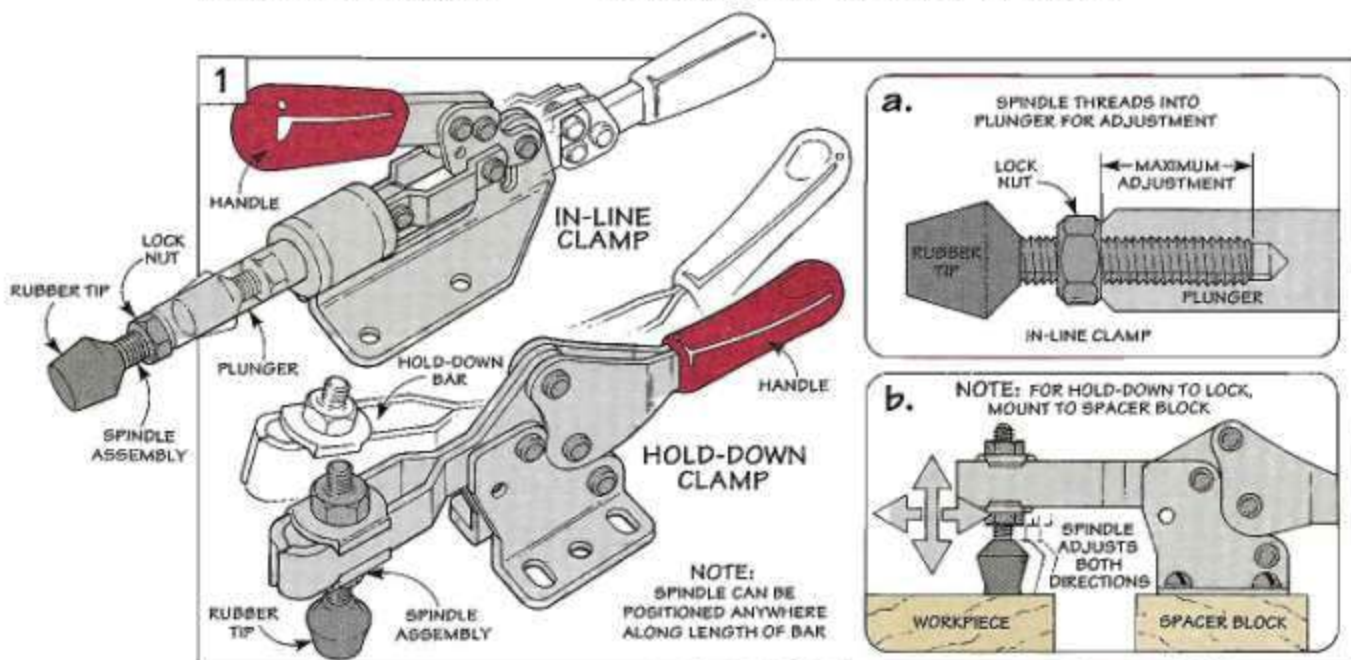

Hold-Down Clamps

Of the toggle clamps I've used, I find the hold-down type to be the most useful. These clamps come in a wide variety of sizes with handles that lock in either the vertical or horizontal position, see photo.

They all work basically the same way. As you can see in the

photo, when the handle is flipped to the locked position, the bottom of the pad is even with the base of the toggle clamp.

This means that the clamp may have to be mounted to a spacer block that's approximately the same thickness as the workpiece, refer to Fig. 1b.



ROUTING SMALL PARTS

When I need to rout small pieces on the router table, I hold them with a toggle clamp that's mounted to a "sled." The sled can be moved up close to the bit without worry.

Although toggle clamps usually hold the workpiece securely, for this type of application I add a cleat to each side of the workpiece to prevent it from twisting out of position.

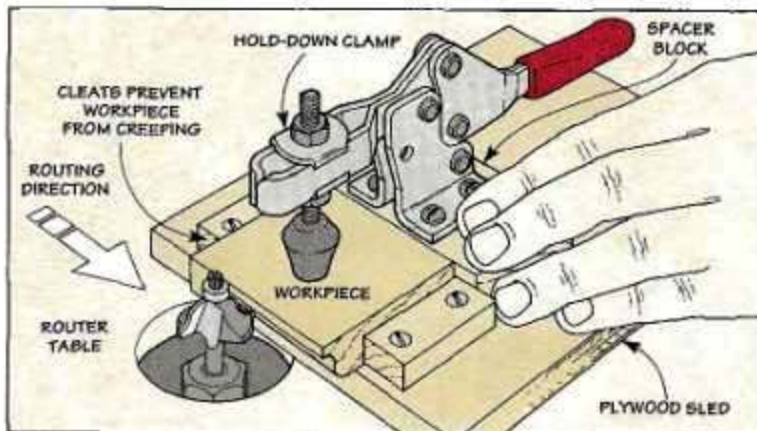

DRILL PRESS CLAMP

You can also use a hold-down clamp to hold small pieces to the table of your drill press.

To make it easy to reposition the clamp, drill a hole through the spacer block and extend a bolt through it and down through the slot in the drill press table.

Then thread a wing nut onto the bolt, so you can position the clamp where you need it and tighten it in place.

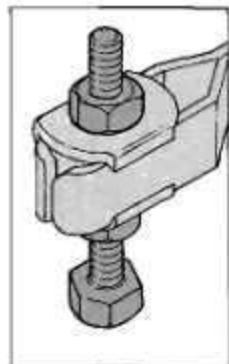
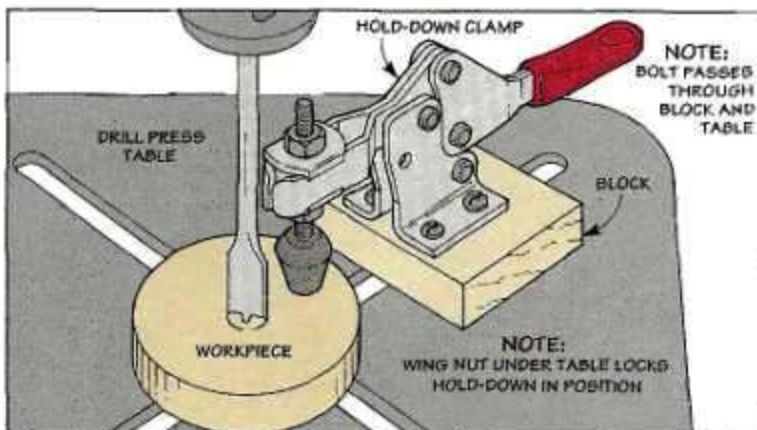

If you need an extra long spindle, you can use a bolt.

RIPPING JIG

Hold-down clamps are ideal for making a ripping jig — used to rip a clean edge on rough-sawn lumber. The jig has two (or more) hold-down clamps mounted to spacer blocks that are in turn mounted to a plywood sled.

To use the jig, clamp the stock down on the jig so one edge extends over one edge of the sled. Then just push the jig to trim a clean edge on the stock.

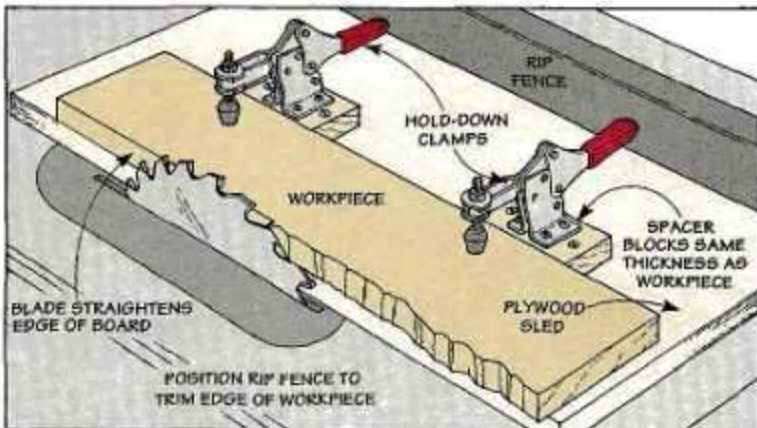

In-Line Toggle Clamps

Professional cabinet shops use in-line toggle clamps to assemble panels and frames. Just like hold-down clamps, in-line clamps come in a wide variety of sizes that can be used in home shops, see photo.

All in-line clamps work the same way. When the handle is moved to the locked position, the

plunger extends straight out to press against the workpiece.

The only tricky part is positioning the in-line clamp so the spindle is at the correct height to exert pressure where you want it. To do this, you may have to mount the toggle clamp to a spacer block.



GLUE-UP JIG

In-line toggle clamps are handy for light assembly work, like gluing up door frames.

In this application, a plywood base is made to hold the frame between cleats. Then the toggle clamps are positioned to exert pressure at the joints.

Positioning the clamps may take some time. But once in place, it's just a matter of flipping the toggle clamp levers.

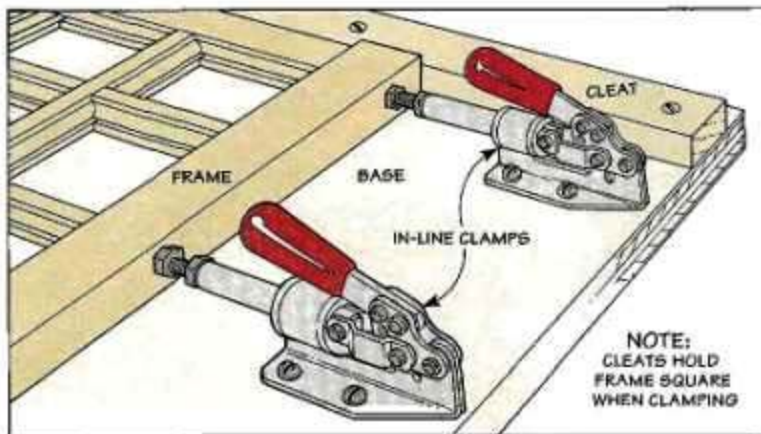

HOLDING SMALL PIECES

An in-line clamp makes a great hold-down for your radial arm saw. Simply mount an in-line clamp to a block. Then screw the block to the fence on your radial arm saw.

Note: To ensure the clamp doesn't lift your fence up when you use the clamp to lock down a workpiece, you'll need to screw the fence to the front table on your saw.

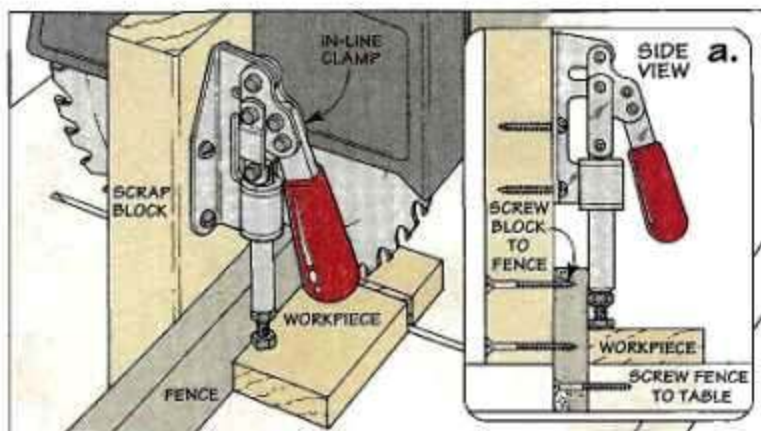

Pull-Type Clamps

In addition to hold-down and in-line clamps, there's another type of toggle clamp that has some use for woodworkers — a pull-type toggle clamp.

These clamps are similar to in-line clamps, but instead of pushing out, they draw the parts together with either a U-bolt or a latch-type pull.

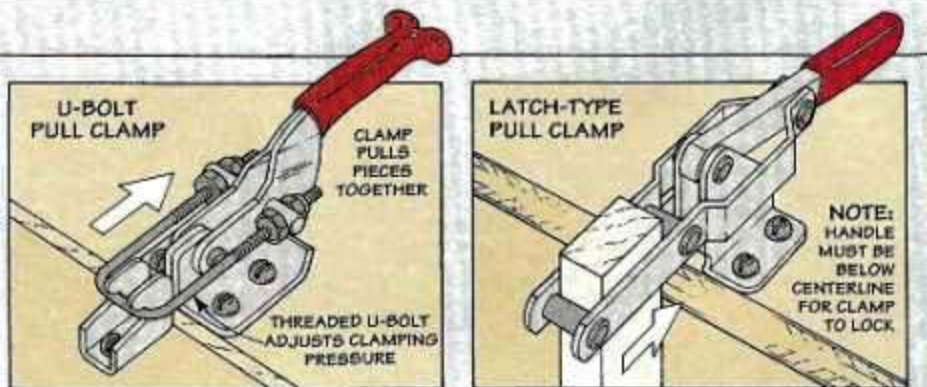

Sources

ShopNotes Shop Supplies is offering some of the hardware and supplies needed for the projects in this issue.

We've also put together a list of other mail order sources that have the same or similar hardware and supplies.

BEVEL GRINDING JIG

If you would like to purchase exactly the same hardware that we used to make the Bevel Grinding Jig on pages 6 and 7, there's a kit available.

This kit contains the hardware only. You'll need to supply your own wood.

Note: The same or similar hardware is available in most hardware stores or building supply centers.

- (1) 1/2"-Dia. Steel Rod, 16"-long
 - (2) 3/16" Eye Bolts (overall length is 2 1/2")
 - (2) 3/16" x 1 1/2" Carriage Bolts
 - (4) 3/16" Wing Nuts
 - (4) 3/16" Washers
- S6803-100** Bevel Grinding Jig Hardware Kit\$8.95

ROUTER TRAMMEL

Shop Supplies is offering a kit of the hardware to make the Router

Trammel shown on pages 8 and 9.

This kit contains only the hardware, not the 1/4" -thick Masonite.

- (1) 1/4" I.D. Plastic Wing Nut
 - (1) 1/4" Fh Machine Bolt
 - (1) 1/4" Hex Nut
 - (1) Fender Washer
- S6803-200** Router Trammel Hardware Kit..... \$2.95

TOOL CARRY-ALL

To make the Tool Carry-All shown on page 10, I used four brass-plated catches to attach the trays to the case. I also used four brass woodscrews to attach the handle to the removable tray.

The catches and screws are available through *ShopNotes Shop Supplies*.

These catches (or similar catches) are also available through some of the mail order sources listed below.

- (4) Brass Plated Catches w/Screws
 - (4) No. 8 x 1" Brass Fh Woodscrews
- S6803-300** Tool Carry-All Hardware Kit..... \$10.95

CLAMPING STATION

The Clamping Station shown on page 22 is designed to work with

1/2"-diameter pipe clamps. *ShopNotes Shop Supplies* is offering Jorgensen (Pony) pipe clamp fixtures. This includes the head and the end of the clamp. (You'll need to supply your own piece of 1/2" black pipe.)

This type of clamp is also available at most hardware stores and building centers. It can also be purchased from some of the mail order sources listed below.

- S1307-250** 1/2" Pipe Clamp Fixture.....\$10.95

TOGGLE CLAMPS

ShopNotes Shop Supplies is offering two types of toggle clamps: a hold-down style and an in-line toggle clamp, see page 28.

Each clamp comes with a rubber-tipped spindle.

The in-line clamp also comes with a 1 1/2"-long hex head bolt. This bolt can be used in place of the rubber-tipped spindle for different applications.

Similar clamps can also be purchased from several of the mail order sources listed below.

- S1301-622** Hold-down Clamp.....\$13.95
- S6803-400** Heavy Duty In-line Clamp.....\$21.95

MAIL ORDER SOURCES

Similar hardware and supplies may be found in the following catalogs. Please call each company for a catalog or for ordering information.

Constantine's 800-223-8087 Catches, Pipe Clamp Fixtures, Toggle Clamps	Woodcraft 800-225-1153 Pipe Clamp Fixtures, Toggle Clamps	Woodhaven 800-344-6657 Plastic Wing Nuts
Highland Hardware 800-241-6748 Pipe Clamp Fixtures, Toggle Clamps	The Woodworkers' Store 612-428-2199 Plastic Wing Nuts, Catches	Craftsman Wood Service 800-548-9367 Catches, Pipe Clamp Fixtures
Trend-Lines 800-767-9999 Pipe Clamp Fixtures, Toggle Clamps	Woodworker's Supply 800-645-9292 Pipe Clamp Fixtures, Toggle Clamps	Shopsmith/Wood- working Unlimited 800-543-7586 Catches, Toggle Clamps

ORDER INFORMATION

BY MAIL

To order by mail, use the form enclosed with a current issue. The order form includes information on handling and shipping charges, and sales tax. Send your mail order to:

**ShopNotes
Shop Supplies
P.O. Box 842
Des Moines, IA 50304**

BY PHONE

For fastest service use our Toll Free order line. Open Monday through Friday, 8:00 AM to 5:00 PM Central Time.

Before calling, have your VISA, MasterCard, or Discover Card ready.

1-800-444-7527

Note: Prices subject to change after July 1, 1992.



Scenes From the Shop

Yesterday's craftsmen took as much pride in their tools as their projects. These old measuring and layout tools were crafted from rosewood and boxwood and trimmed in brass and are as useful today as they were in years past. From the boxwood framing square to the rosewood panel marking gauge, each tool is a joy to use.