

T I P S • T O O L S • T E C H N I Q U E S

# ShopNotes™

\$4.95

Issue 1

## Premiere Issue



- Shop-Built Router Table
- Table Saw Accessories
- Tips for Accurate Crosscutting
- Elu Router Review



# ShopNotes

Issue 1 January 1992

**EDITOR** Donald B. Peschke  
**EDITORIAL DIRECTOR** Douglas L. Hicks  
**MANAGING EDITOR** Terry J. Strohmman  
**ASSISTANT EDITOR** Richard S. Peters  
**CONTRIBUTING EDITORS** Gordon Gaippe  
 Phillip A. Totten  
 Tim Robertson

**CREATIVE DIRECTOR** Ted Kralicek  
**ASST. ART DIRECTOR** Cary Christensen  
**ILLUSTRATOR** Kurt Schultz  
**CONTRIBUTING ILLUS.** Chris Glowacki  
 Robert H. Whitmer  
**DESIGN DIRECTOR** Ken Munkol  
**DESIGNER** Jan Hale Svec  
**PHOTOGRAPHER** Crayola England  
**SHOP MANAGER** Steve Curtis

**CIRCULATION DIRECTOR** Liz Brudeason  
**SUBSCRIPTION MANAGER** Sandy Baum  
**CIRCULATION ANALYST** Jim Woodson  
**NEWSSTAND SALES** Kent A. Buckton

**CONTROLLER** Paul E. Gray  
**ACCOUNTING** Linda O'Rourke  
**BOOKKEEPING** Julianne Spears  
**NETWORK ADMIN.** Douglas M. Lidster  
**ADMINISTRATIVE ASST.** Cheryl Scott  
**RECEPTIONIST** Lori Seibert  
**BUILDING MAINTENANCE** Ken Griffith

**MARKETING DIRECTOR** Robert Murry  
**PROJECT SUPPLIES** Leslie Ann Gearhart  
 Linda Jones  
**TECHNICAL SUPPORT** Jonathan Garbison  
**CUSTOMER SERVICE** Linda Morrow, Mgr.  
 Laura Bathe-McNelly  
 Jennie Enos  
 Joy Johnson  
 Tammi Juhl  
 Marci Hooper  
**SHIPPING DEPARTMENT** Jerry Carson, Supr.  
 Gloria Sheehan  
 Ronald Long  
 Donnie McVey

ShopNotes is published bimonthly (Jan., March, May, July, Sept., Nov.) by Woodsmith Corporation, 2200 Grand Ave., Des Moines, IA 50312. Printed in U.S.A. ShopNotes® is a registered trademark of Woodsmith Corporation.

©Copyright 1992 by Woodsmith Corporation. All rights reserved.

Subscriptions: Single Copy, \$4.95. One year subscription (6 issues), \$19.95. Two years (12 issues), \$35.95. Canada/Foreign, add \$4.00 per year.

Second Class Postage Pending at Des Moines, IA and at additional offices.

Postmaster: Send change of address to ShopNotes, Box 11204, Des Moines, IA 50340-1204

Subscription Questions? Call 1-800-333-6854 8am-5pm Central Time, weekdays.

**T**he premiere issue of a new magazine sets the stage for all the ideas and stories to be told in the years to come.

This first issue of *ShopNotes* was born of a trait common to all woodworkers . . . we like to talk about our shops, the tools we use, the techniques, and the way things work.

That's what you'll find in *ShopNotes*. The whole idea is to have a magazine that's dedicated entirely to your shop. If you like working in your shop, even when you're not building a particular project, maybe just puttering around, this magazine ought to appeal to you.

**IDEAS.** When we first started talking about the idea of this new magazine, we were in the *Woodsmith* shop. (*Woodsmith* is a magazine for woodworkers that has plans for building furniture and small projects, and the techniques that go along with them.)

As we looked around the shop, we began talking about all the tips, shop projects, and new ideas that could be in *ShopNotes*.

**ROUTER TABLE.** For example, in this issue we're featuring an all-new design for a router table. This all started with the router table shown in *Woodsmith* almost 10 years ago.

We've built a lot of projects on that old table, and we've had a lot of ideas for improving the original design.

The new Router Table is presented in a way so you can choose the parts of the table that work best for you.

Build just the table top with the phenolic insert, or build the

new fence with the T-slot for adding accessories. (If you don't build anything else, the fence is worth looking at.)

As a bonus in this premiere issue, we've also added a special plans section for an enclosed router table cabinet.

**JIGS AND ACCESSORIES.** The one area that probably has the most interest for woodworkers are the special jigs and accessories that help you get the most out of your tools.

In this issue we're showing three accessories for your table saw. And in future issues we will show jigs for your band saw, drill press, radial arm saw, router, and all the other tools in your shop.

**TOOLS.** As we began talking about tools themselves, it started a little controversy. How should we approach tool reviews?

We didn't want to list all the routers, for example, on the market with a chart comparing their features. This approach makes it tough to get a sense for any one tool and how it operates.

So we decided to select one tool in this issue, (the Elu Plunge Router) and concentrate on it with a full-fledged discussion about what we like and don't like. This in-depth approach should tell you exactly what we think about the tool.

**TECHNIQUES.** And, finally, in every issue we want to highlight a particular woodworking technique. This time it's a collection of ideas and tips on how to get the best performance when crosscutting on the table saw.

**THE FUTURE.** I hope you enjoy this premiere issue of *ShopNotes*. I'm looking forward to its future.



# Contents

## Jigs and Accessories \_\_\_\_\_ 4

Three table saw accessories: Small-Piece Clamp, Push Block, and Table Saw Jointing.

## Elu Plunge Router \_\_\_\_\_ 10

The Elu #3338 plunge router is put to the test and comes out a real winner.

## Crosscutting \_\_\_\_\_ 12

Problems involved with crosscutting on the table saw and helpful tips on solving them.

## Table Saw Cabinet \_\_\_\_\_ 14

This simple cabinet mounts to the side of a table saw providing storage for blades, a rip fence, various accessories, and even a miter gauge.

## Router Table \_\_\_\_\_ 16

This router table is loaded with options starting with a very simple base. (As a special bonus we've included a set of plans for an enclosed router cabinet.)

## Router Table Top \_\_\_\_\_ 18

The sandwich construction of the top provides a heavy, vibration-free work surface. And allows a smooth surface for the miter gauge slot and the removable insert plate.

## Router Table Fence \_\_\_\_\_ 22

Sliding faces allow you to vary the bit opening to fit the bit you're using. The T-slot makes attaching accessories quick and easy.

## Fence Accessories \_\_\_\_\_ 26

A bit guard, free-hand guard, adjustable featherboard, and shop vacuum attachment make the router table safer and easier to use.

## Shop Solutions \_\_\_\_\_ 28

Five shop-tested tips: A Spring-Loaded Sanding Block. A Woodscrew Tip. Sawhorse Tray. Pipe Clamp Rack. And a Magnetic Tool Bar.

## Book Review \_\_\_\_\_ 30

A look at *The Workshop Book* by Scott Landis.

## Sources \_\_\_\_\_ 31

Hardware, project supplies, and mail order sources for the projects in this issue.



Elu Plunge Router page 10



Crosscutting page 12

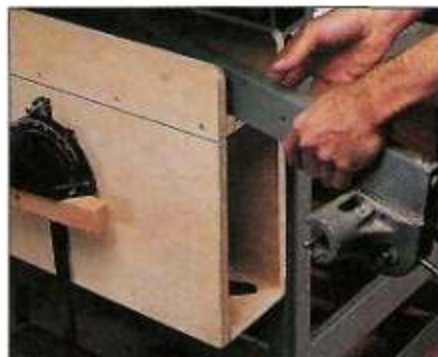

Table Saw Cabinet page 14



Router Table Fence page 22

# Small-Piece Clamp

*Cutting small pieces safely is easy when you use this simple clamp that attaches to your miter gauge.*

Recently I was building a project that required cutting several small pieces on the table saw. Rather than take any chances, I made a clamp jig that attaches to my miter gauge.

The idea of the jig is that two "arms" hold the workpieces securely and keep my fingers away from the blade.

The clamp consists of three pieces: a *back jaw*, a *front jaw*, and an *adjustable spreader* that connects the two jaws, see Fig. 1. A slot cut in the spreader allows you to adjust the distance between the jaws so you can cut different size pieces.

A carriage bolt and wing nut at the other end provide the clamping pressure. When the nut is tightened down on the bolt, it pinches the two jaws together like a vise to hold the workpiece in place as you make a cut.

## CONSTRUCTION

I began work on the clamp by cutting the two jaws and the



spreader from  $\frac{3}{4}$ "-thick hardwood, see Fig. 1.

**SPREADER.** The spreader has a slot in one end to make the clamp adjustable. To cut this slot, first drill a  $\frac{3}{8}$ " hole  $2\frac{1}{2}$ " from the end, see Detail in Fig. 1. Then make two parallel cuts up to the hole with a hand saw or sabre saw.

After the slot is cut, drill countersunk shank holes at one end of the spreader, and screw it to the end of the front jaw, see Fig. 2.

**HANGER BOLT.** The slotted end of the spreader fits over a hanger bolt and is tightened down with a

wing nut, see Fig. 2. Screw a hanger bolt into the end of the back jaw, see Fig. 2a. (To insert the hanger bolt, refer to tip in margin on the opposite page.)

After the bolt is installed, thread on a washer and wing nut. When you tighten the wing nut, it pinches the spreader, locking one end of the front jaw in place.

**ATTACHING THE CLAMP.** To attach the clamp to the miter gauge, first locate the holes for the screws.

Set the miter gauge at  $90^\circ$ , and place the back jaw against the

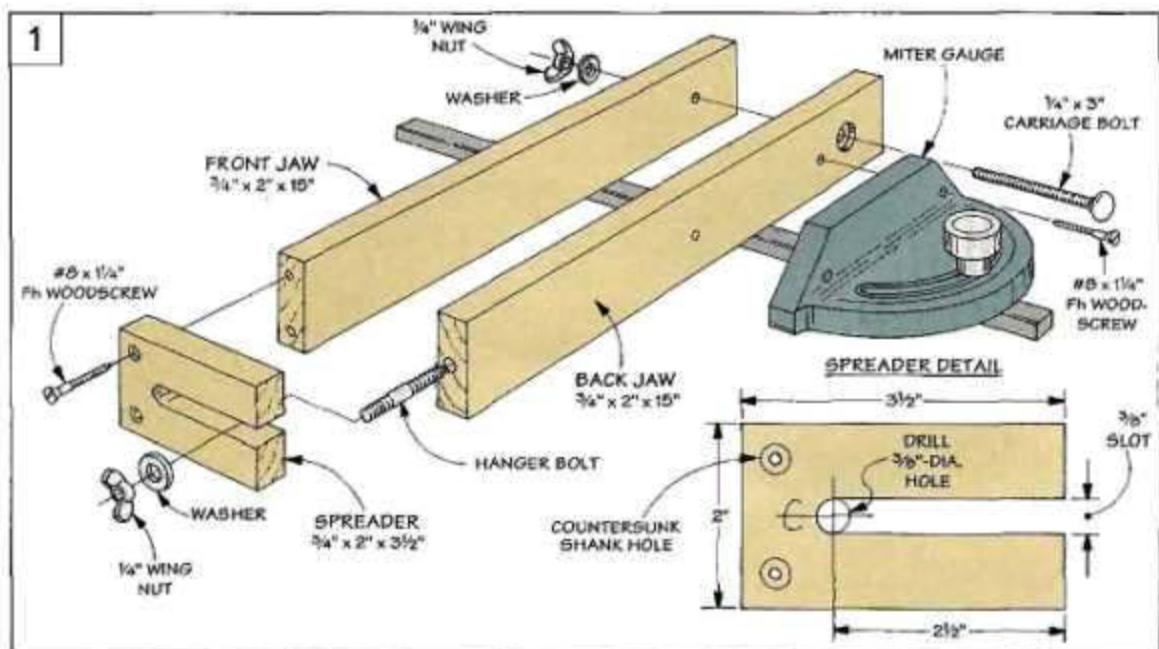

miter gauge, see Fig. 3. Then slide the clamp over so the end touches the saw blade. Now mark the position of the two screw holes in the back jaw, and drill pilot holes.

A carriage bolt is used to close the jaws around the workpiece at the right end of the clamp. Mark the position of the bolt on the back jaw, see Fig. 3. Then counterbore a hole to accept the head of the bolt, see Fig. 4a. Finally, drill a  $\frac{1}{4}$ " hole through both jaws for the carriage bolt.

Now screw the clamp to the miter gauge, insert the carriage bolt and washer, and tighten the wing nut, see Fig. 4.

### USING THE CLAMP

To use the clamp, loosen the wing nut on the spreader (at the left end of the clamp), and adjust the jaws to the width of your workpiece. Then tighten the nut.

Next, insert the workpiece between the jaws at the right end of the clamp, and tighten the wing nut on the carriage bolt.

Note: When clamping pieces wider than 1", the top edge of the jaws may tip in. To prevent this, cut a spacer the same width as the workpiece, and insert it between the top edges of the jaws.

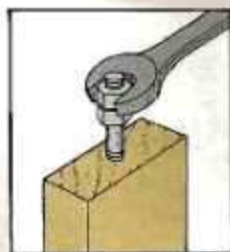
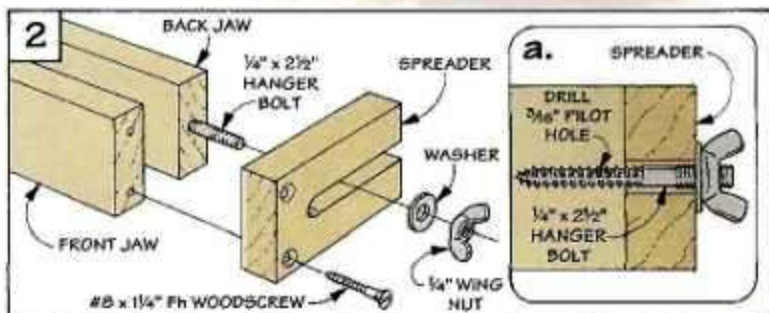

To insert a hanger bolt, thread two nuts on the shaft and tighten them together. Then use a wrench to screw the bolt in.

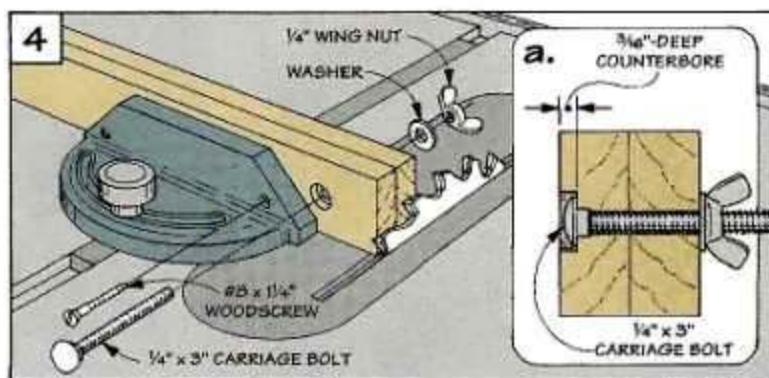
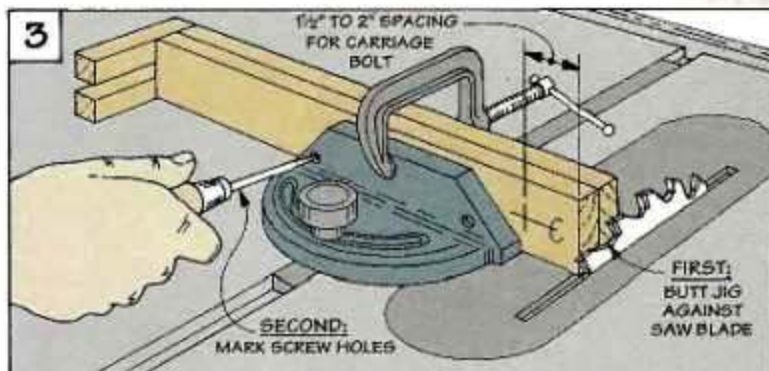

## Miter Cuts

When you tilt the miter gauge to 45°, the end of the clamp is too far away from the blade to safely hold and support a small workpiece.

So, you need to reposition the clamp on the miter gauge for 45° miter cuts.

To do this, unscrew the clamp and tilt the miter gauge to 45°.

Then slide the clamp

along the miter gauge until the front corner of the back jaw just touches the edge of the blade, see drawing at right.

With the clamp in this position, mark new locations of the screw holes, and drill pilot holes. Then screw the clamp to the miter gauge.

Now turn on the saw, and trim off the back corner of the back jaw.

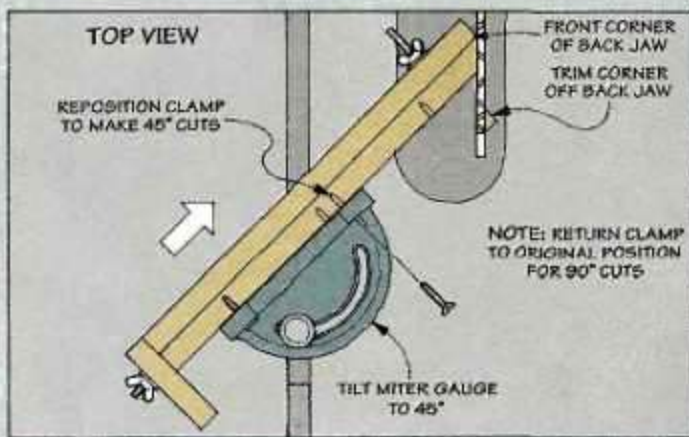

# Push Block

**P**ush blocks get chewed up. But this one solves that by making the parts that get chewed up replaceable. Yet, you can reuse the handle (the part that takes the time to make).

A good push block is probably one of the most important accessories for your table saw. It should be designed to solve common problems when ripping. (See box on next page.)

This push block has three parts: a replaceable main body (a scrap piece of 2x4), a Masonite heel that hooks over the end of the workpiece, and a handle.

**HANDLE.** The handle is the key to the whole system, so it's worth making a good

one. I cut the handle out of a scrap piece of 2x4, but any 1½"-thick stock will do. Start by cutting the handle blank 3½" wide by 9" long.

Now, lay out the shape shown in Fig. 1 on the blank. Then cut the handle to shape on a band saw, and round over the sharp edges by filing them smooth.

The handle is attached to the 2x4 body and the heel with a drywall screw. Drill a shank hole for this screw at a slight angle (about 5°) so when the screw is tightened down it will pull the main body and heel tight



into the notch in the handle, see Fig. 1a.

**BODY AND HEEL.** When the handle is complete, the next step is to cut out the body and the Masonite heel.

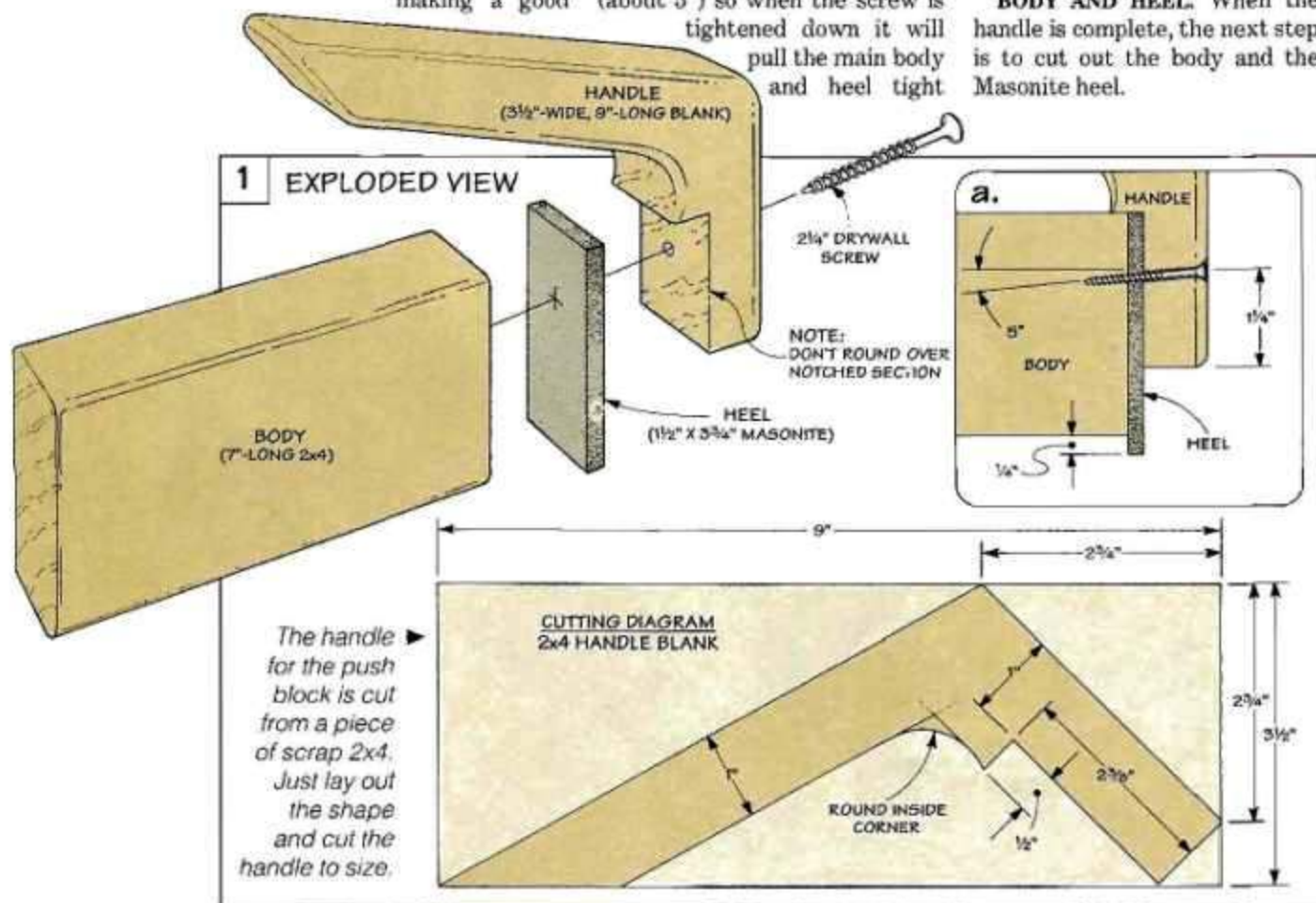

For the body, cut a scrap piece of 2x4 7"-long. The heel is cut from a piece of 1/4"-thick Masonite so it's the same width (or even slightly less) than the body, and extends 1/4" below the bottom edge of the body, see Fig. 1a.

**ShopTip:** Since the body and heel will get chewed up, it's a good idea to cut several of these pieces and keep them on hand for replacements.

**ASSEMBLY.** To assemble the push block, set the parts on a flat surface and clamp them together, see Fig. 2. Then screw them together with a drywall screw.

**ShopTip:** I used a drywall screw because it doesn't need a pilot hole. This is especially handy when it comes time to replace the heel and body.

When the body and heel get chewed up, you don't have to replace them, see Fig. 3. Instead, just flip both parts, clamp and screw them together, see Fig. 3a.

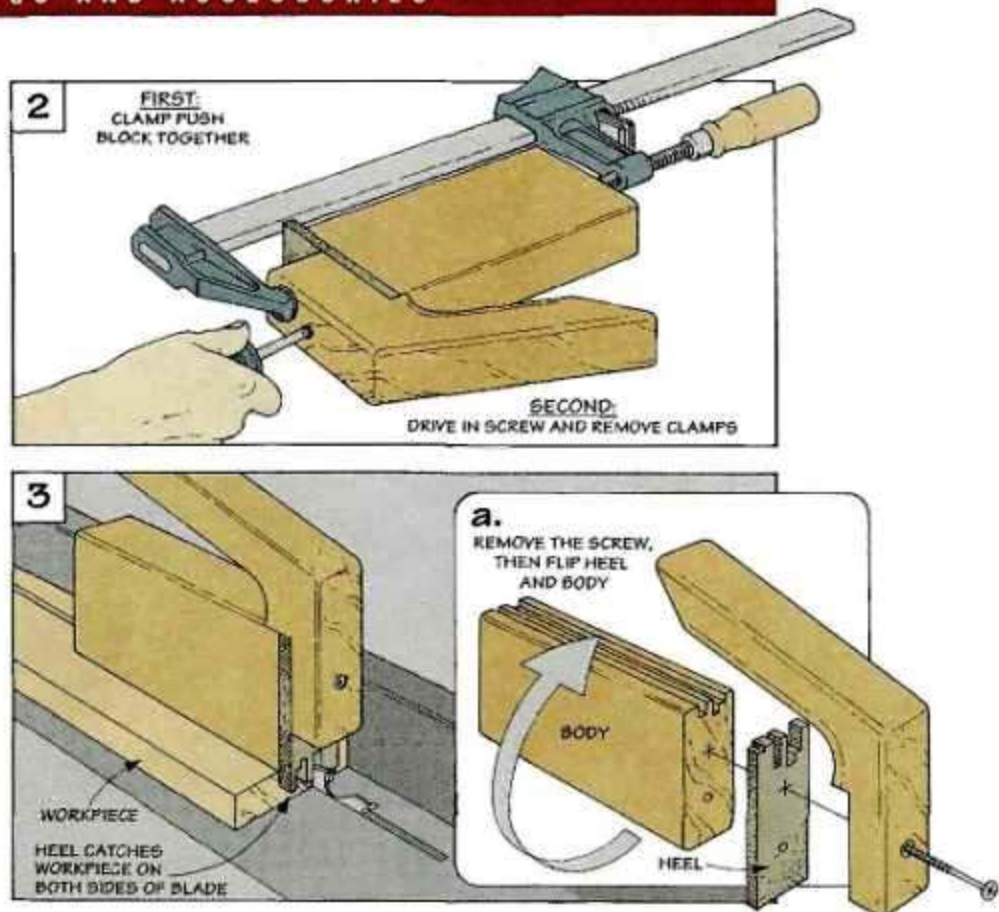

## Using a Push Block



▲ This push block is very helpful when ripping thin strips. The body keeps the thin strip steady, while the heel pushes the thin strip through the saw blade without kickback.



▲ To prevent a workpiece from pulling away from the rip fence, center the push block between the blade and fence, and apply gentle pressure toward the fence during the cut.

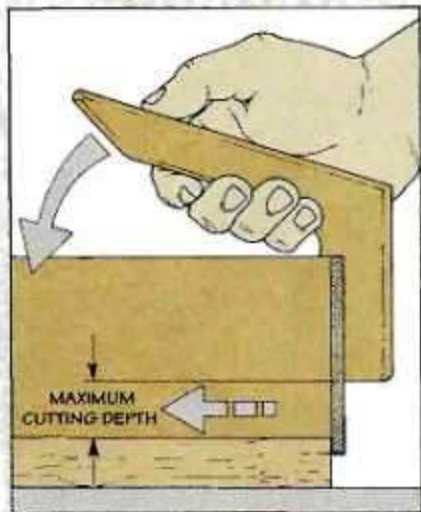

▲ The angled handle provides a comfortable grip — and force in two directions. It allows you to push straight ahead and press the workpiece down (to prevent chattering).

# Table Saw Jointing

*Converting your table saw into a jointer isn't as difficult as you might think — if you build this special fence.*

**M**ore than one eyebrow was raised in the shop when I mentioned that there was a way to joint the edge of a piece of wood on the table saw. It works on the same principle as a jointer, just adapted to the table saw.

On a jointer, a workpiece is pushed along an infeed table which is set slightly lower than the jointer knives. As a workpiece is pushed over the knives, they cut the wood and joint the edge.

An outfeed table is set flush with the knives to support the workpiece and prevent the knives from taking too deep a cut.

You can use this same principle to convert your table saw into a simple jointer. Note: This "jointer" takes off  $\frac{1}{8}$ " per pass. The secret is converting your rip fence into the infeed and outfeed tables, see photo above.

## CONVERTING THE FENCE

Converting your rip fence for jointing is easy. All it takes is a strip of  $\frac{3}{4}$ "-thick plywood and a piece of Masonite.

**PLYWOOD.** Start by ripping a strip of plywood 4"-wide. To make it easier to joint long pieces, cut the plywood 12" longer than the length of your rip fence and temporarily clamp the plywood to your fence.

**MASONITE.** Next a piece of Masonite is glued to one end of the plywood to become the outfeed side, see Fig. 1. (Note: I used  $\frac{1}{8}$ " Masonite since its thickness is the same as most carbide-tipped saw blades.)

To determine the length of the Masonite, measure from the back end of the plywood strip to the center of the saw blade. This positions the front of the strip directly over the center of the blade — which provides the maxi-

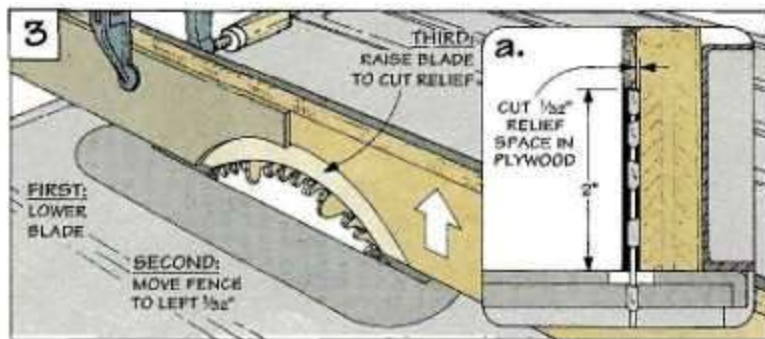
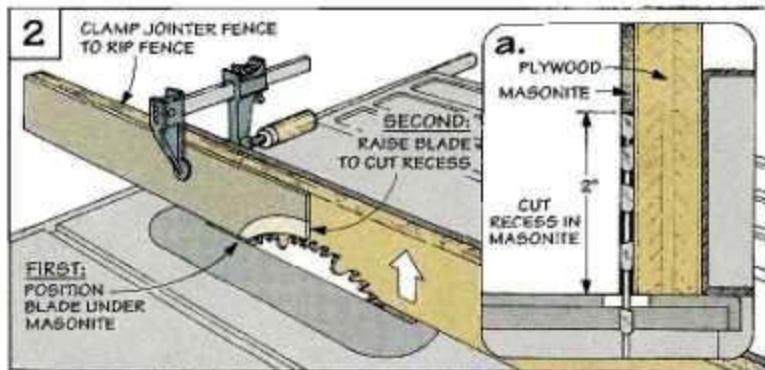
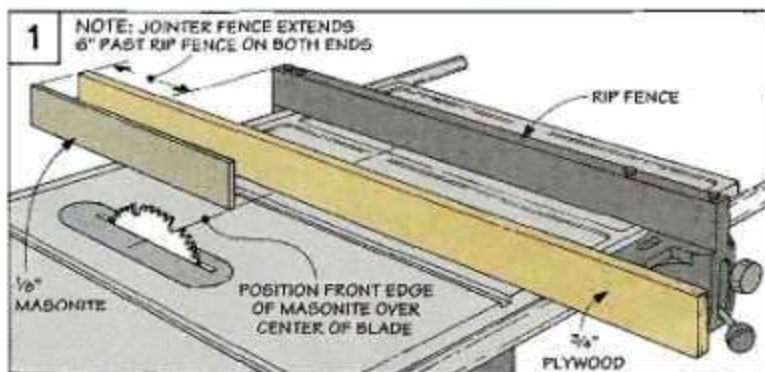



mum cut and exposes the minimum amount of blade, see Fig. 2. Now cut a 4"-wide strip of Masonite to length and glue it to the plywood strip, refer to Fig. 1.

**CUT RECESS.** The next step is to cut a recess in the plywood fence for the saw blade. To do this, first clamp the plywood fence to your rip fence. Then slide the rip fence over so it butts up against the blade. Lower the blade and move the fence to the left an additional  $\frac{1}{8}$ ", see Fig. 2.

Now turn on the saw and slowly raise the blade up into the Masonite to a height of 2" (this allows you to joint wood 2" thick). To prevent the blade from pinching against the plywood fence, lower the blade, move the fence over an additional  $\frac{1}{32}$ ", and raise the blade again, see Fig. 3.

**ADJUST FENCE.** After you've cut the relief in the plywood (and whenever you use this "jointer" fence), you'll need to adjust the position of the fence so the face of the Masonite is flush with the saw blade, see Fig. 4.

But before you do this, first

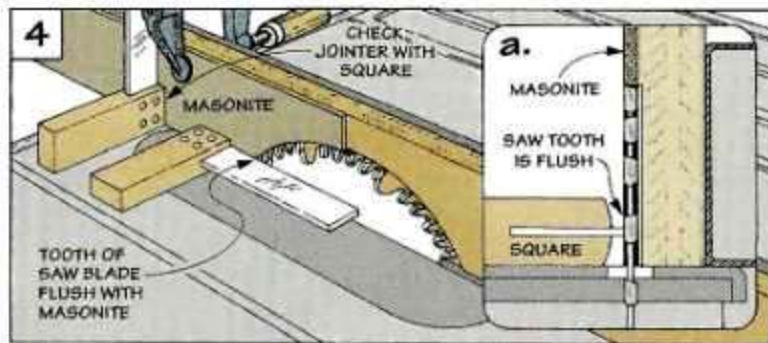

*A try square can be used to quickly align the table saw jointer with the blade.*

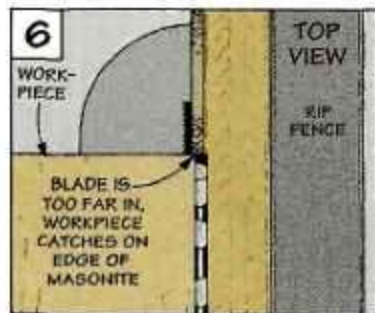
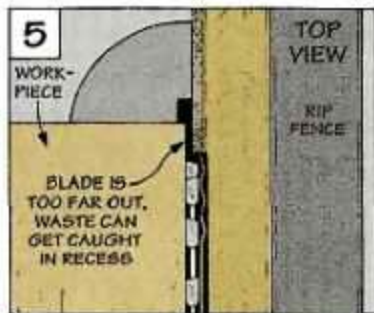

check to make sure the rip fence is square to the saw table.

Then, place the blade of the try square against the face of the Masonite, and adjust the fence so the square just touches the outside edges of the teeth on the saw blade, see Fig. 4a.

Note: If after you've adjusted the fence, you find that the workpiece pivots in towards the fence, the blade may be sticking out too far, see Fig. 5. Or, if the workpiece catches on the Masonite, the blade is in too far, see Fig. 6. In either case, re-adjust the fence.

## Using the Jointer

To joint an edge with the table saw jointer, slide edge of the workpiece along the "jointer" fence applying even pressure to both the infeed and outfeed sides, see Fig. 1. As you finish a pass, apply pressure to *only* the outfeed side — or the workpiece may pivot in toward the blade, see Fig. 2.

If you're jointing a long, warped piece, you may want to take off the high points on the ends (or in the center) to prevent the workpiece from pivoting around the rip fence. This can be done by starting at the sections with high points. Then, joint the piece along its full length.

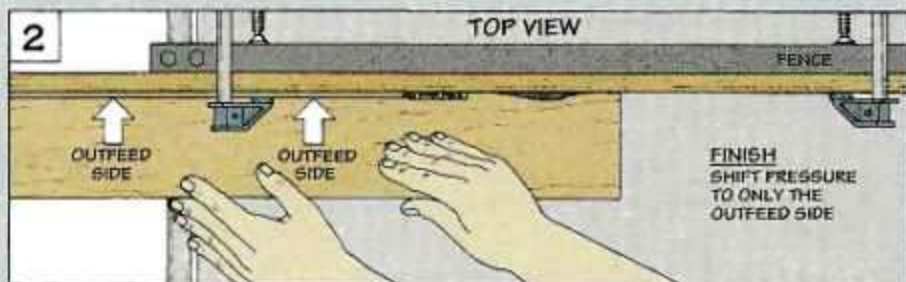
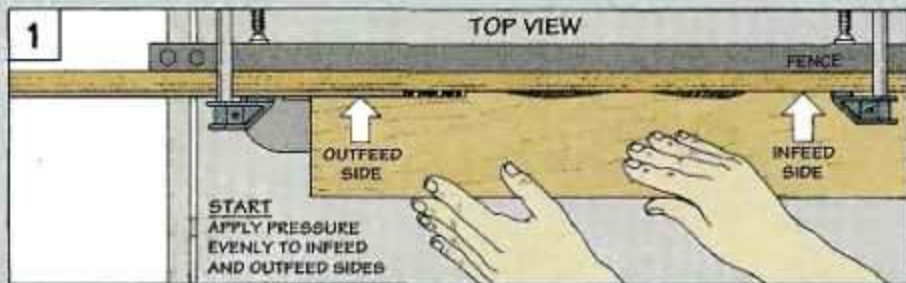

# Elu Plunge

*The top-of-the-line Elu 3338 plunge router is loaded with special features.*

If you were to pay almost \$300 for a router, you'd expect something special. With the Elu variable speed, electronic plunge router, you get it.

Plunge routers aren't new. Elu, a Swiss manufacturer, built the first one in 1951. (Black and Decker purchased Elu in 1984, but the Elu line of tools is still manufactured in Switzerland.) It wasn't until the 1980's that plunge routers became popular in the U.S.

**FEATURES.** So what does a plunge router do that a conventional router can't? Just what the name says — it allows you to plunge a bit into the workpiece. This plunge feature is great for routing stopped dados, mortises, and surface designs.

The important thing in making a plunge cut is for the bit to enter and exit the workpiece at exactly 90°. The slightest amount of side-to-side play can ruin the cut. This "sloppy" plunging action is a problem on some plunge routers.

However, the Elu makes plunge cuts with the precision of a Swiss watch. The guide rods are made out of case hardened steel and are turned to tight tolerances (the same tolerances specified for most router bits).

The rods slide in 2"-long bushings made of phosphor bronze (an expensive material that is self-lubricating and has incredible wear resistance). By comparison, some plunge routers have bushings only on one side, or use a pair of nylon bushings.

**USING THE ROUTER.** You can't really appreciate the engineering of the Elu until you take it off the shelf and use it. Grasp the handles. Flip the "on" switch — it's a

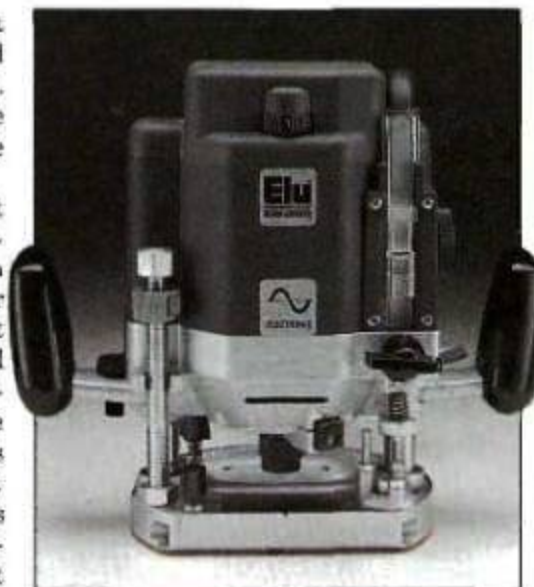

contoured plate positioned right by the fingers of your left hand, and can be reached without letting go of the handle.

Now, with just slight downward pressure, push the motor housing down the guide rods until it reaches a pre-selected depth. Then lock the plunge lock lever that's within easy reach of the fingers of your right hand and start routing.

After completing the cut, release the lock lever. The motor housing travels back up the guide rods — keeping the spinning bit safely above the workpiece until you turn the router off. That's the beauty of using the Elu plunge router — you feel in control.

## MOTOR

One of the advantages that the Elu has over a standard router is its variable speed motor. It allows you to select a speed from 8,000 to 20,000 RPM. The idea of a variable speed motor is to be able to match the turning speed to the material and the size of bit you're using. And — it's quiet.

At the slowest speed, the Elu motor is quieter than my kitchen blender. I've become hooked on the slow-speed option on the Elu. Even when working with hardwoods, I rarely turn the speed up past the Level 3 setting (16,000 RPM), and frequently I use the Level 1 setting (8,000 RPM).

I like the slowest speed with bits that make partial cuts (like a round-over bit). It's quieter, and I've experienced no compromise in cutting performance.

The biggest advantage to the slower speed though is the bit doesn't heat up like

it would in a conventional router turning at 22,000 RPM. By using only the speed necessary to make the cut, the chance of burning the wood or the bit is reduced.

**ELECTRONIC CONTROL.** As soon as you turn on the router, the electronic circuitry takes over, and the motor smoothly accelerates up to speed. This "soft start" feature eliminates the wrist-twisting torque you'd expect from a big, 2¼ h.p. motor.

After the motor reaches operating speed, it won't bog down in the middle of a heavy cut. Instead, the speed is electronically increased to maintain the RPM at the level you selected, like the cruise control on a car.

## DEPTH ADJUSTMENT

One thing that's always bugged me about routers is setting the bit height. You have to loosen the motor housing to adjust the bit to the exact height you want. When you retighten it, the height of the bit changes just a fraction, and you need to set the height all over again. Sound familiar?

The Elu's depth setting system eliminates all that with a series of progressively finer adjustments. The heart of the system consists of a depth stop bar and a turret, see photo below.

The stop bar is adjusted by a rack and pinion gear. This stop bar determines the depth of cut when it contacts one of the three screws on the turret. (The three screws allow you to preset three different depths.) The turret feature is particularly useful when making a cut, like a dado, in progressively deeper increments.

The point is when you set the depth stop bar and turret, you can be sure that the bit will cut to that exact depth — and you can return to any setting, exactly.

To add to the precision, there's a magnified scale with a hairline indicator. And finally, a micro-adjuster on the end of the depth stop rod allows you to fine tune the depth of cut.

All of these depth setting features are fine in the freehand routing position, but how do they work when the router is mounted upside down in a router table?



▲ A three position turret and a magnified hairline indicator allow for precise depth settings

Making micro-adjustments on some table-mounted plunge routers can be a frustrating experience. It's almost impossible to get a good grip on the height adjustment nut.

Elu has solved this problem by using an extension knob. Unfortunately, you have to pay extra (about \$20) to get this option.

### COLLET SYSTEM

The Elu's plunge mechanism, variable speed motor, and depth adjustments work great. But it's the collet system that impresses me the most. If you've ever had a bit slip out of the collet and ruin a project, you'll appreciate how the Elu system works.

**COLLET.** First of all, the Elu collet is 1 $\frac{3}{8}$ " long. It grips a full one inch of the shank of a bit. (Other routers have collets that grip as little as  $\frac{1}{2}$ " of the shank.)

But there's more to the holding power of the Elu collet than just a long grip. There are six slits that run almost the entire length of the collet (compared to two or three in some collets). These slits create "fingers" that exert uniform pressure around the shank of the bit as the collet nut is tightened.

**COLLET NUT.** The collet nut is also designed differently than other routers. The collet snaps into a retaining ring in the collet nut. Then the nut and the collet assembly are screwed to the end of the spindle shaft. The benefit of this comes when you remove the bit. As you loosen the nut the collet is pulled loose from the bit.

The only problem is, if you forget to snap the collet all the way into the nut before tightening it, you'll end up using a pair of pliers to remove the bit and collet from the shaft. But if you snap the two pieces together, you won't have to worry about a slipping collet.

One final thing I liked about the Elu's collet system — the way

the bit is tightened. With many routers, you're always fighting with two wrenches. On the Elu, you press a button to engage a pin that locks the spindle shaft. So you only need one wrench to loosen or tighten the collet nut.

The Elu collet system is about as good as you can get, except you only get a  $\frac{1}{2}$ " collet (for bits with  $\frac{1}{2}$ "-diameter shanks) when you buy the router. If you want a  $\frac{1}{4}$ " collet, it's a \$30 option.

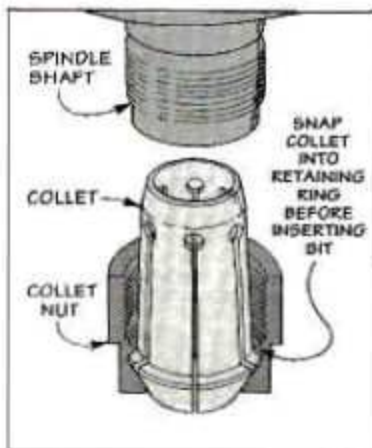

▲ With the Elu collet system, loosening the nut pulls the collet free from the router bit.

### CONCLUSIONS

The closer you look at the Elu 3338, the more you realize this tool was designed by people who understand woodworking.

Details count. Like the fact that the base is designed to accept standard guide bushings from Black & Decker — and also from Porter Cable.

Even little things like spring-mounted knobs make a difference. (The springs prevent the knobs from vibrating loose while you're routing.)

The list goes on, but the point is made. They were really thinking when they engineered this tool.

Bottom line, is it worth \$300? Well, if you admire a nearly perfect router, the Elu 3338 is as close as you can get.

# Crosscutting

Everyone takes crosscutting on the table saw for granted. After all, it should be easy to make 90° cuts with a miter gauge — but making *perfect* crosscuts can be quite a challenge.

## ADJUSTMENTS

The frustrating thing about making precise crosscuts is there isn't usually just one problem.

**SAW BLADE.** An often overlooked problem is that your saw blade may not be parallel to the miter gauge slots. A quick way to check this is to use a combination square and the procedure in the top two photos below.

By using this method, you can check the blade's alignment. If the blade is not parallel to the miter slot, the table saw trunnion needs to be adjusted. (The trunnion is the assembly that holds the saw arbor to the bottom of the table.) Normally all you need to do is loosen the bolts that hold the trunnion

### Safety Note:

Always unplug your table saw before making adjustments.

To check your blade, first mark a tooth. Then, place a square in the slot and adjust it so the end of the square touches the side of the marked tooth.



Next, slide the square and rotate the blade backward until the marked tooth aligns with the square. If it just touches, the slot and blade are aligned.



To check your miter gauge, first loosen the locking knob. Then, use a try square and set the head 90° to the saw blade and tighten the knob.

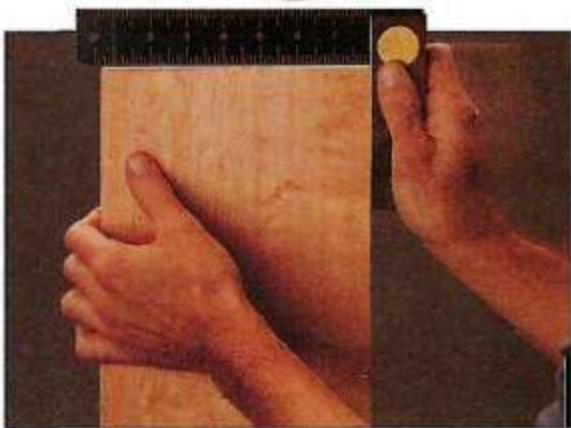

and tap the trunnion in the direction needed.

**MITER GAUGE.** A more common problem is the swiveling head of the miter gauge isn't exactly 90° to the miter gauge slot — usually because the graduations on most miter gauges aren't accurate. They're really only good for rough positioning.

To get a more accurate setting, loosen the locking knob and use a try square to set the miter gauge 90° to the saw blade, see bottom photo at left.

**DYNAMIC TESTING.** However, even this is not as reliable as you might think. To get an accurate setting, you should make a *dynamic* test.

Everything we've done up to this point has been a *static* test or adjustment. In other words, we haven't turned on the saw to make a cut.

The only way to be sure that you're getting perfect crosscuts is to do a *dynamic* test. One method I use to make a dynamic test is shown in Fig. 1.

Set your miter gauge as close as you can to 90° with a try square. Then make a crosscut on a piece of scrap (the wider, the better). After making the cut, flip one section over, and butt the ends together. If there's a gap, the miter gauge is not set at 90°.



▲ Fig. 1. To check that your miter gauge is 90° to the blade, crosscut a piece of scrap. Flip one piece over and butt the cut ends together. If there's a gap the miter gauge needs to be adjusted.

## STANDARD PROCEDURES

Once you're sure your table saw and miter gauge are set up accurately, there are two simple procedures to help ensure clean, accurate crosscuts.

**MAKING A CLEAN CUT.** First, always crosscut with the good side of the board face up. This way any tear-out will be on the side that won't be seen.

Second, you can ruin a perfect crosscut by pulling the board back along the side of the saw teeth after making a cut. Instead, slide the workpiece away from the blade after the cut. Then you can pull the miter gauge and workpiece back.

## AUXILIARY FENCE AND STOP BLOCK

One of the most important things you can do to make better crosscuts is to use an auxiliary fence. This is nothing more than an extension fence (I use a strip of  $\frac{3}{4}$ " hardwood) attached to the face of the miter gauge, see Fig. 2. (Most miter gauges have slots or pre-drilled holes for screwing on a fence.)

An auxiliary fence improves the quality of the crosscut in two ways.

**SUPPORT.** It provides extra support for the workpiece, preventing it from pivoting during the cut. This is particularly helpful on long, wide pieces that tend to drag on the table surface.

**WANDER.** Even more important, an auxiliary fence can prevent the tendency of a spinning saw blade to pull the workpiece into the blade causing a bad cut. (This is sometimes called wander, or creep.)

One common way to prevent wander is to glue a strip of sandpaper to the face of the auxiliary fence. The sandpaper provides extra "grip" and keeps the workpiece from slipping.

The way I prefer to prevent wander is to clamp a stop block to the fence, see Fig. 3. To counter the pull of the blade, I push the workpiece in the opposite direction — tight against the block, while making the cut.

**TEAR-OUT.** One other benefit of an auxiliary fence is that it can help reduce tear-out on the back edge

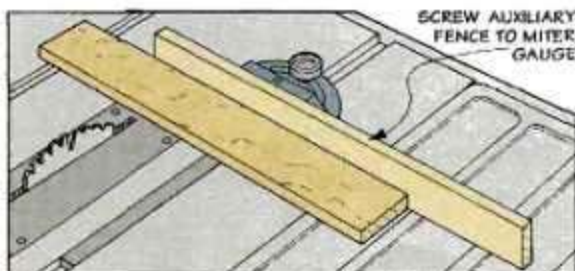

▲ Fig. 2. To provide support along the length of a long board when crosscutting, screw an auxiliary fence to your miter gauge. This prevents the board from dragging or swivelling during the cut.

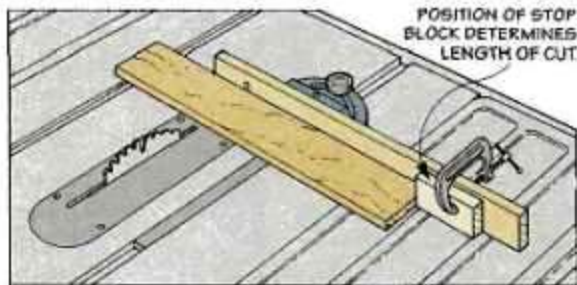

◀ Fig. 3. Clamp a stop block to the fence to crosscut pieces to the same length.

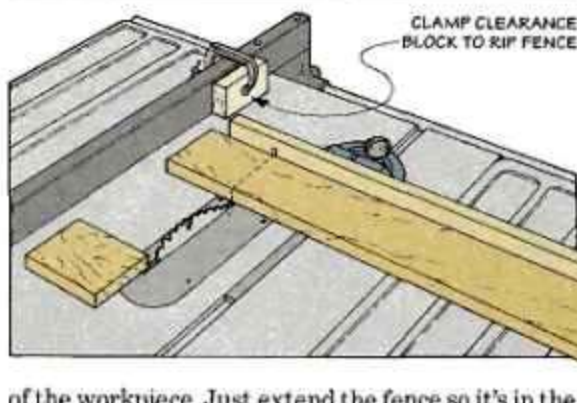

◀ Fig. 4. To cut short pieces, clamp a clearance block to the rip fence and push the piece through with an auxiliary fence.

of the workpiece. Just extend the fence so it's in the path of the blade, see Fig. 2. This way the fence supports both the workpiece and the waste piece, reducing the chance of the grain tearing out.

**REPETITIVE CUTS.** Besides improving the quality of the cut, using an auxiliary fence with a stop block can also make quick work of cutting several pieces to the same length.

Instead of marking each piece with a pencil (and hoping all the marks and cuts are accurate), I use a two-cut procedure with an auxiliary fence.

The first cut is made with the stop block positioned so the piece is cut slightly (about  $\frac{1}{2}$ " longer than the finished length you want. (This makes sure that this end of each piece is perfectly square.)

Then, just reset the stop block, flip each piece end-for-end, and cut it to final length. By using the same set-up (and pushing against the stop block), you ensure they're all *exactly* the same length.

Note: One minor problem can foul this up. Be sure to cut a sawdust relief on the bottom corner of the stop block to prevent any sawdust from building up between the stop block and the workpiece.

**SHORT PIECES.** When I need several short pieces all the same length, I clamp a clearance block to the rip fence to use as a length gauge, see Fig. 4.

It's okay to use the rip fence along with the miter gauge as long as the block provides enough clearance so the cut-off can't bind between the blade and fence. It also helps if the auxiliary fence extends to support the cut-off piece and pushes it all the way through and beyond the saw blade (so the cut-offs don't stop right next to the saw blade).



To prevent sawdust from building up between the workpiece and the stop block, cut a sawdust relief on the bottom corner.

# Saw Cabinet

*This space-saving cabinet gives you a way to store your table saw accessories so they're right at your finger tips*

**D**oes this sound familiar? You're just getting ready to rip a board and there's no convenient place to store the miter gauge. And when you're trying to crosscut, the rip fence is in the way.

To store the miter gauge and rip fence close at hand, I built a cabinet that hangs on the side of my table saw, taking advantage of the unused space below the table extension.

**FEATURES.** The cabinet has a door which effectively doubles the storage space — allowing you to store the arbor wrench, saw blades, and other accessories inside.

The miter gauge hangs in a quick-access holder on the door. And there's a channel on top of the cabinet for the rip fence.



**TOP/BOTTOM.** The door and the back are joined together with the top and bottom (C, D). Cut both of these pieces to the same length as the back and  $4\frac{1}{2}$ " wide, see Fig. 1.

Note: The  $4\frac{1}{2}$ " width will accommodate most saw fences — but you can change the width to fit your fence.

After the top and bottom are cut to size, screw them to the back piece (A), see Fig. 1.

## CONSTRUCTION

To build the cabinet, I started by cutting the back (A) and the door blank (B) from  $\frac{3}{4}$ "-thick plywood, see Fig. 1. I cut both pieces  $15\frac{1}{2}$ " wide by 23" long (large enough to store 10"-dia. saw blades side-by-side).

**END PIECE.** To mount the door, an end (E) is cut to fit between the top and bottom pieces, see Fig. 2. To provide more holding power for the hinge screws, I cut this piece from  $\frac{3}{4}$ "-thick hardwood (not plywood).

The width of this piece has to allow for the hinge. So measure the width of the bottom ( $4\frac{1}{2}$ "

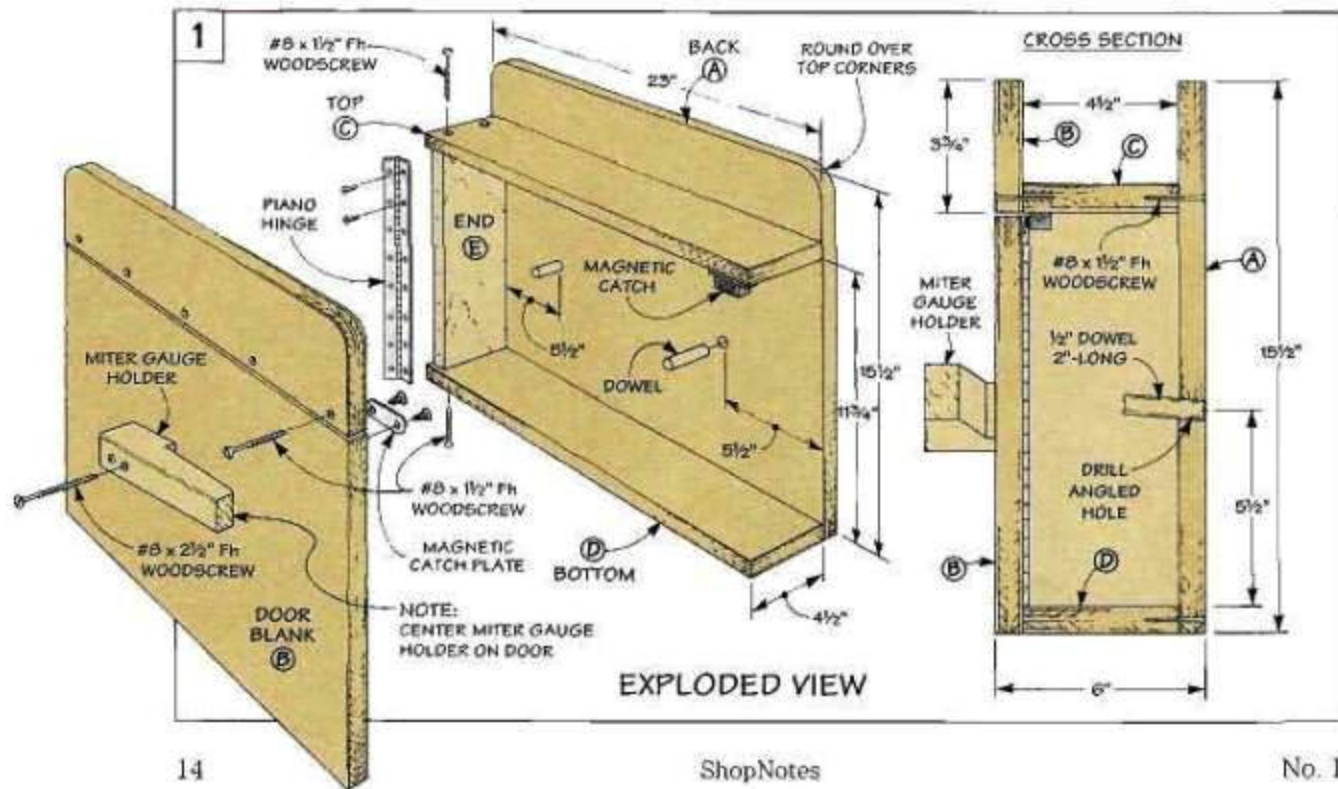

and subtract the thickness of the hinge. Then screw the end between the top (C) and bottom (D).

**DOOR BLANK.** Before the door can be mounted, the door blank (B) is ripped into two pieces. One piece becomes the door. The other piece is screwed to the top (C) to complete the channel for the rip fence, see Fig. 1.

**BLADE HOLDERS.** Before installing the door, I laid out and drilled holes for angled dowels that hold the blades inside the cabinet, see Cross Section in Fig. 1.

**MOUNT DOOR.** When you're ready to mount the door to the cabinet, cut a piano hinge the same length as the door. Then screw the hinge to the door, see Fig. 2. Next, screw the other flap of the hinge to the end (E). Finally, add a magnetic catch, see Fig. 1.

**MOUNT THE CABINET.** If the angle of the legs on your table saw interferes with mounting the cabinet, add a couple of spacer blocks. Counterbore holes in the blocks, and bolt them to the side of the saw, see Fig. 3. Now all that's left is to screw the cabinet to the blocks.

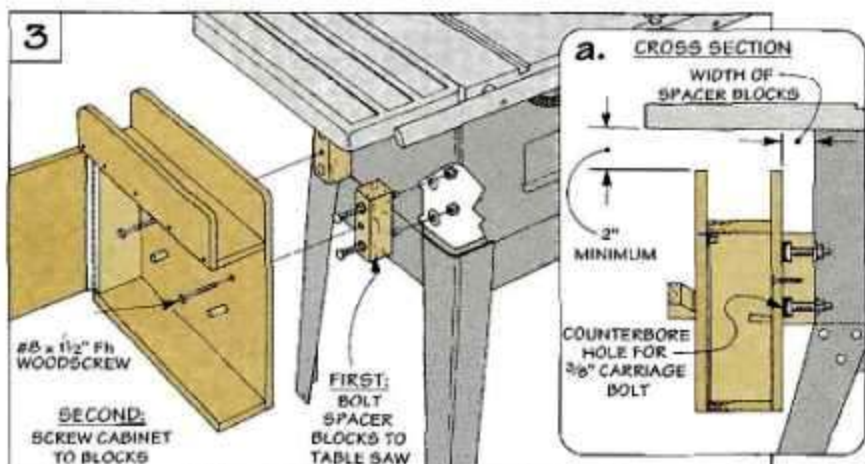
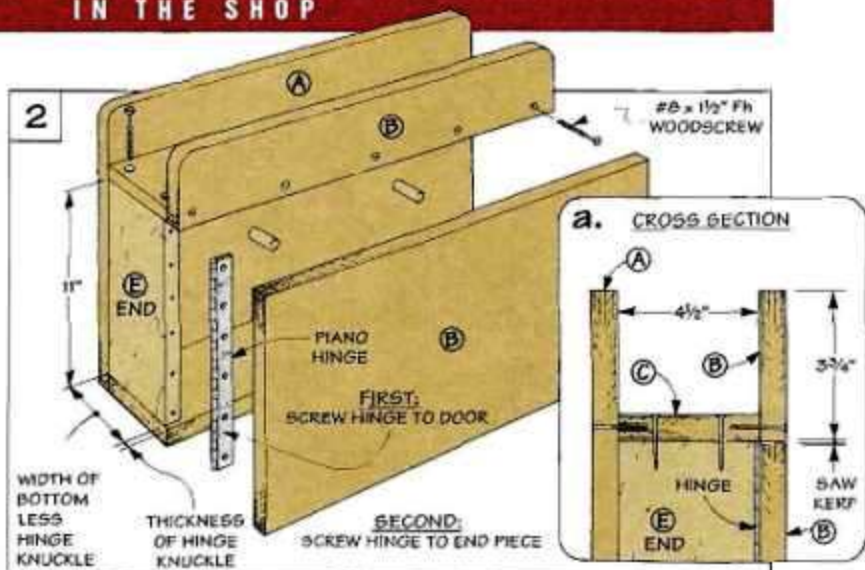

## Miter Gauge Holder



▲ A quick-access holder is mounted to the cabinet for your miter gauge. It allows you to slide the miter gauge in place — even with an auxiliary fence attached.

One of the most awkward things to store is a miter gauge — especially when it has an auxiliary fence attached to it.

Storing it becomes even more of a problem if you want easy and quick access when you need it.

Our solution is this simple quick-access holder that mounts to the front of the cabinet door.

**HOLDER.** The holder is just a bracket with a tapered notch.

To make it, cut a scrap piece of 2x4 8"-long. Then, rip it to a width of 2", see drawing below.

Next, lay out the tapered notch and cut it out with a sabre saw or on a band saw. Also, drill two countersunk shank holes.

When mounting the holder to the door, tilt it at a slight angle to keep the miter gauge from sliding off the front (open) end.

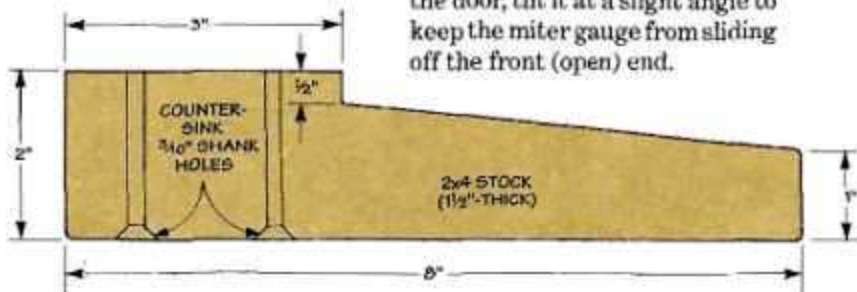

# Router Table

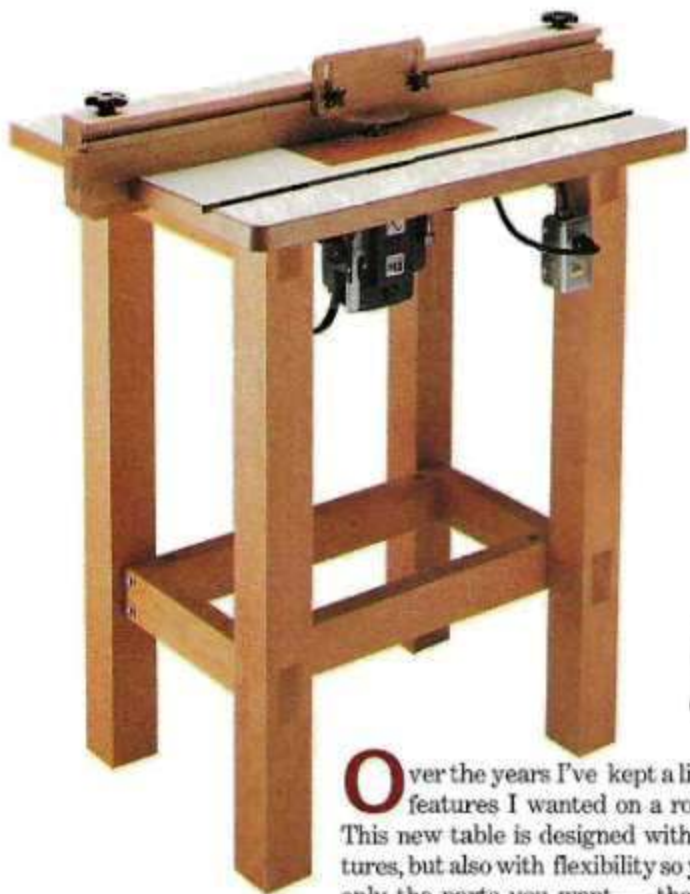

*Build the cabinet (above) or the open frame (left), then add the top and fence. Or build the adjustable fence to fit your own router table.*

Over the years I've kept a list of all the features I wanted on a router table. This new table is designed with those features, but also with flexibility so you can use only the parts you want — the new open base or the cabinet, the new top with an insert plate, or the fence with a T-slot for accessories.

**THE BASE.** We started out building an enclosed base cabinet that has everything . . . bit storage on the doors, a removable sawdust bin, an accessory storage area, and the best feature, it's quiet (the enclosed cabinet dampens most of the router noise.) The plans for this cabinet are in the special pull-out

section included with this issue. Or, you can opt for the easy-to-build open frame (plans on next page).

**THE TOP.** As for the top, I thought three features were essential. First, I wanted an insert plate to hold the router. This way the router can be lifted out of the top to change bits, or removed completely for free-hand routing. I also wanted a heavy top (to dampen vibration), and a miter slot.

**FENCE.** If you don't build any other part of this router table, consider building the fence. It has a T-slot on the face that's designed to accept a variety of accessories (refer to pages 26 and 27). And the clamping system is designed to attach to any table.



▲ The router is mounted to a removable insert plate so it can be lifted out for changing bits or free-hand routing.

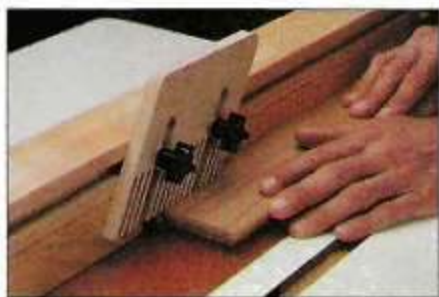

▲ The fence has a T-slot for attaching various accessories, and sliding faces allow for different sized router bits.



▲ A channel can be routed to accept your miter gauge. This is particularly handy for routing the ends of boards.



# Open-Frame Base

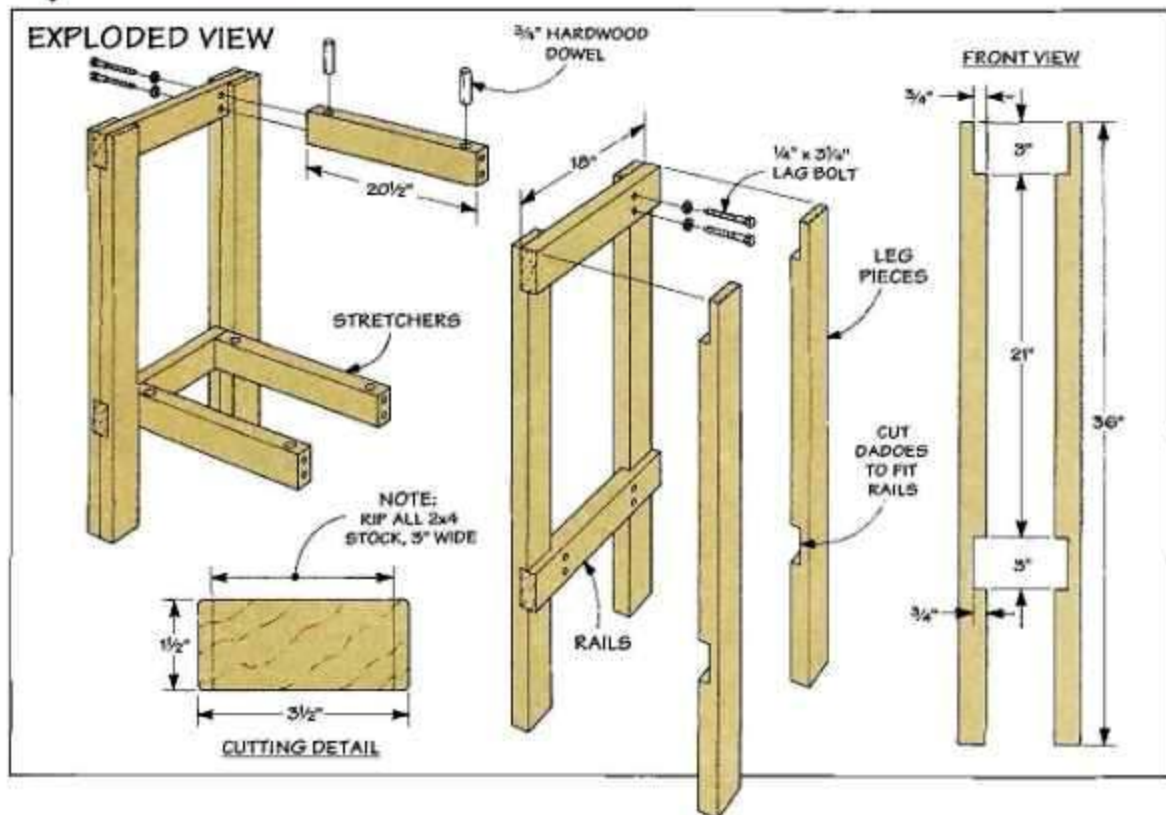

## OPEN-FRAME BASE

This open-frame base is sturdy and easy to build. The entire base is built out of 2x4's. But before I started, I cleaned them up a little by ripping 1/4" off both edges, reducing the width to 3", see Cutting Detail above.

**END FRAMES.** The base has two end frames that consist of two legs and two rails.

**THE LEGS.** Each leg is made

from two 2x4's cut to length and then sandwiched together, see Exploded View. To provide mortises for the rails, I pre-cut wide dadoes in each leg piece before gluing them together. (This simplified the joinery.)

**ASSEMBLY.** After the dadoes are cut in the leg pieces, glue the legs and rails together to complete the end frames, see Fig. 1.

**STRETCHERS.** Next, the end frames are joined together with

three stretchers (Note: To provide access to the router, there isn't a top stretcher between the front legs.)

The stretchers are fastened to the frames with lag bolts. But since the bolts are threaded into end grain, there's a trick to strengthening this joint.

I drilled a hole near the end of the stretcher and glued in dowels before screwing in the lag bolts, see Fig. 2.

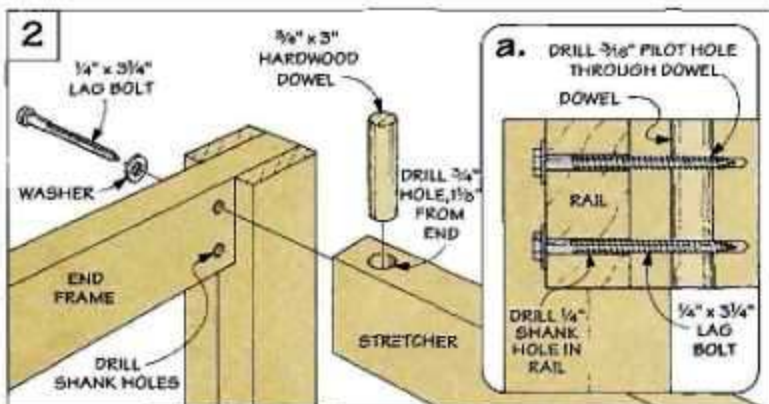
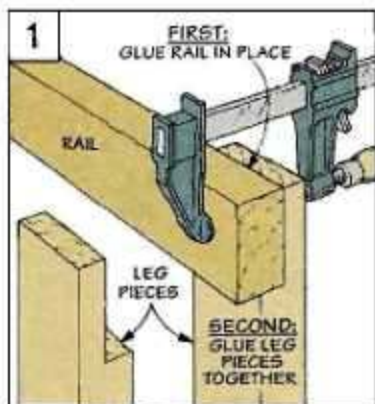

*You can provide extra holding power when screwing into end grain by inserting a dowel. The dowel provides cross-grain strength.*

# Router Table Top



**T**he heart of this router table is the top. It has three important features: the removable insert plate, the miter gauge slot, and its weight.

**REMOVABLE INSERT.** The insert plate is a piece of  $\frac{1}{4}$ "-thick phenolic plastic (you could also use Masonite) that fits in a recessed opening in the table.

The idea is to screw the router to the bottom of the plate. Then you can simply lift the router out

of the table to change bits, or to do freehand routing.

**TECHNIQUE.** The only tricky part to adding an insert plate to the top is routing out the recess. It has to fit exactly. (The technique we used is to rout the recess with a pattern bit in a router, refer to pages 20 and 21.)

## TOP CONSTRUCTION

The top consists of a core of plywood and Masonite, edged with

hardwood, and covered with Formica on both sides.

**THE CORE.** The core of the router table top is a sandwich of two layers of Masonite glued on top of a  $\frac{3}{4}$ " plywood base. The idea here is to make a heavy top (to dampen vibration). Also, when the recess (for the insert plate) and the miter gauge slot are routed in the surface of the top, the two layers of Masonite provide smooth, hard edges.

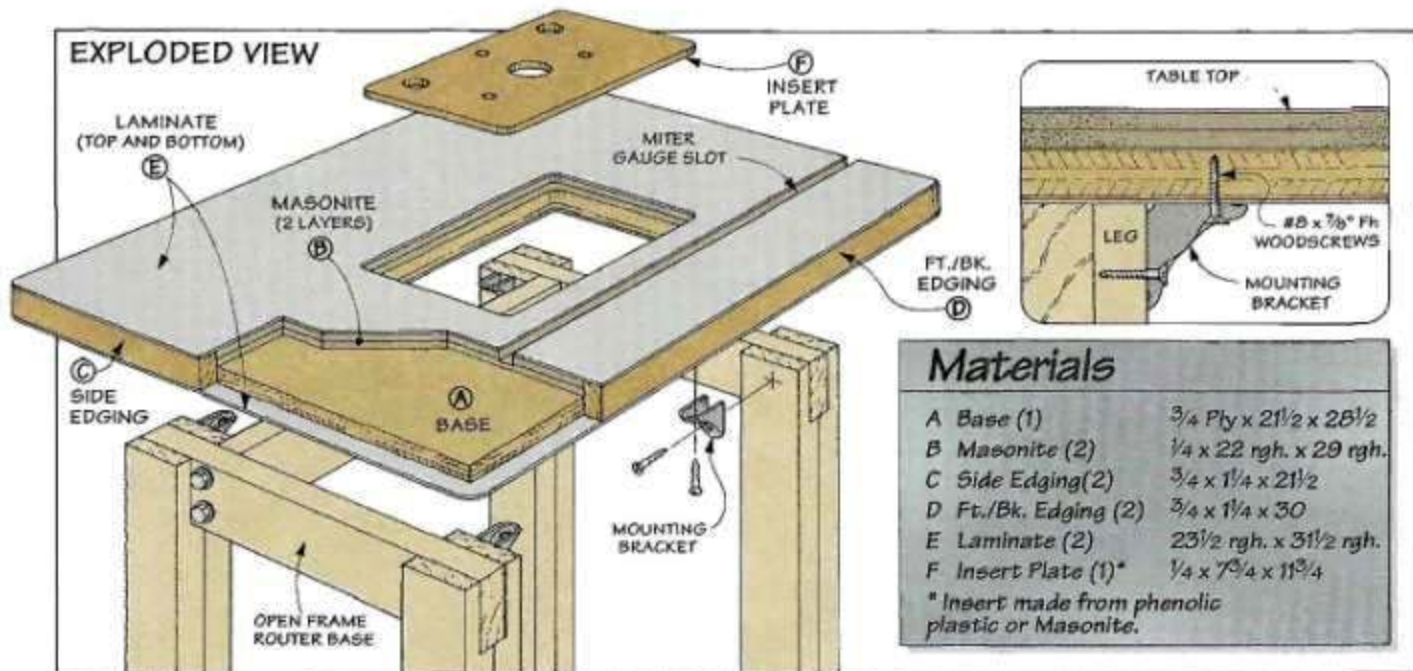

I began making the core section by cutting a *base* (A) to size from  $\frac{3}{4}$ " plywood, see Fig. 1.

**Design Note:** After the edging is installed, the finished dimensions of the top will be 23" x 30".

**MASONITE PIECES.** After the plywood is cut to size, the next step is to cut two pieces of  $\frac{1}{4}$ "-thick *Masonite* (B) and glue them on top of the plywood base with contact cement.

The trick here is getting the edges of the Masonite to align with the plywood.

**TRIM FLUSH.** To solve this problem, I cut the Masonite pieces slightly *larger* than the plywood. Then I routed the edges of the Masonite flush with the edges of the plywood by using a flush trim bit, see Fig. 1a.

**Shop Note:** I used a flush trim bit with a bearing on the top, refer to Fig. 1a. It's also the bit I used to rout the recess for the insert plate and the miter gauge slot, refer to pages 20 and 21.

**EDGING.** After routing the edges of the Masonite, this whole core section is then edged with hardwood. I used  $\frac{3}{4}$ "-thick maple edging (C, D).

First, rip the edging to match the thickness of the top. Then cut it to length, see Fig. 2.

Now, glue and clamp the edging pieces flush with the edges of the top, see Fig. 2a.

**SOFTEN CORNERS.** When the glue is dry, sand or file a radius on each corner, see Fig. 2b.

**LAMINATE.** The last step is to glue *Formica laminate* (E) to *both* sides of the core.

**Design Note:** To prevent one side of the top from expanding and contracting differently than the other, it's important to glue laminate to both sides, see Fig. 3.

Here again, I cut the laminate oversize, then trimmed it . . . but this time with a chamfer bit to chamfer the edge of the top at the same time, see Fig. 3a.

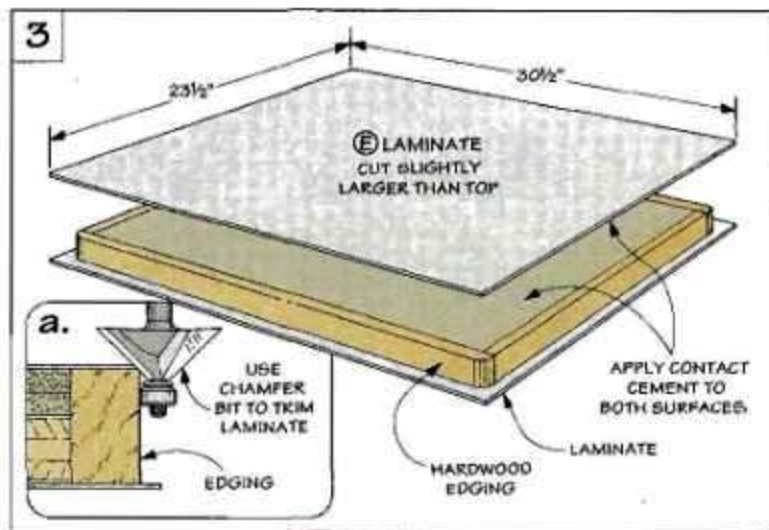
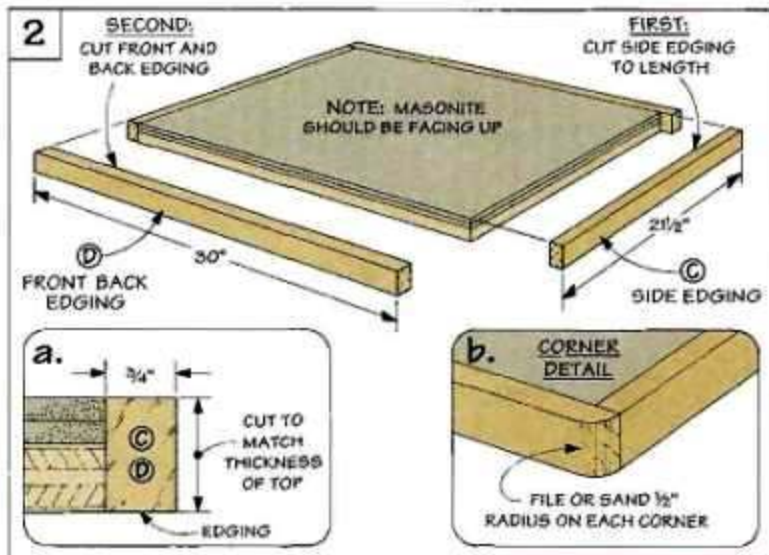
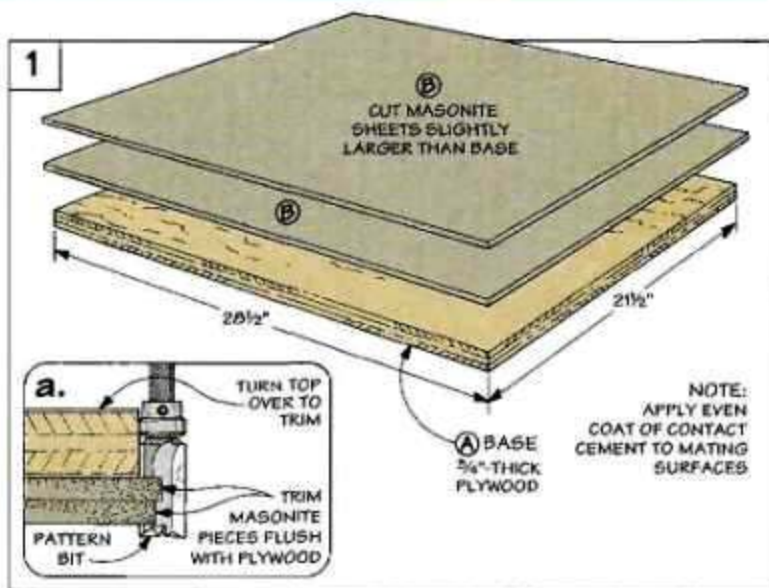

## Insert Plate

After completing the top, the next step is to make the removable insert plate. I used a piece of  $\frac{1}{4}$ "-thick phenolic plastic, but  $\frac{1}{4}$ " Masonite will also work.

**THE INSERT PLATE.** First, cut the insert plate (F) to its finished size, see Fig. 4. (If you plan to use a large router, make the plate about 1" wider than the handles on the router, see page 31.)

After cutting the plate to size, use the base from your router as a template to locate and drill mounting holes and the center hole in the insert. Also drill two finger holes in the plate, see Fig. 4.

Next, sand or file a  $\frac{1}{4}$ " radius on the corners of the insert. (This equals the radius of the pattern bit used to rout the recess, later.) Finally, chamfer all the edges, see Fig. 4a.

**LAYOUT OPENING.** After the insert plate is complete, I used it as a template for laying out the opening in the top. Position the plate 6" from the front edge of the top so it's centered side-to-side, and trace around it, see Fig. 5.

Now the problem is to rout a recess that has a lip around it to hold up the plate.

So, draw cut lines for the lip  $\frac{3}{8}$ " in from the outline, see Fig. 6. Now, drill a hole in each corner of

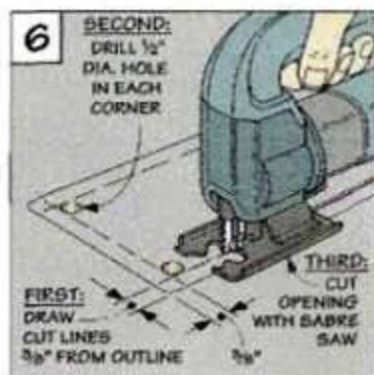
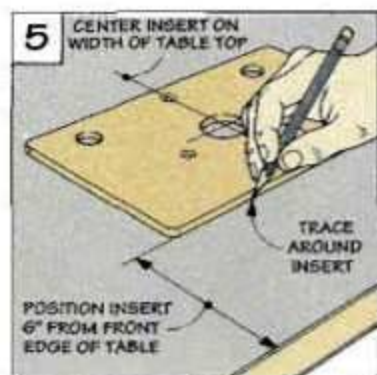
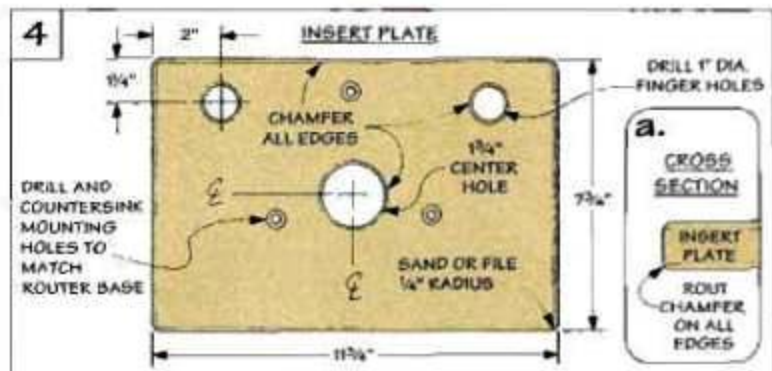

the cut lines. Then use a sabre saw to cut out the opening.

**THE LIP.** The next step is to rout the lip for the insert plate to sit on. The secret to getting the outline of the lip to perfectly match the plate is to use the plate itself as a set-up guide for positioning the guide strips.

**GUIDE STRIPS.** To do this,

place the plate over the opening so it aligns with the outline previously drawn on the top.

Now place guide strips around the insert plate, see Fig. 7. These strips will guide a pattern bit to rout the lipped recess.

The pattern bit I used has cutter length of 1". So, to provide a surface for the bearing to ride

Guide strips are used to rout a recess in the top that's exactly the size of the insert plate.

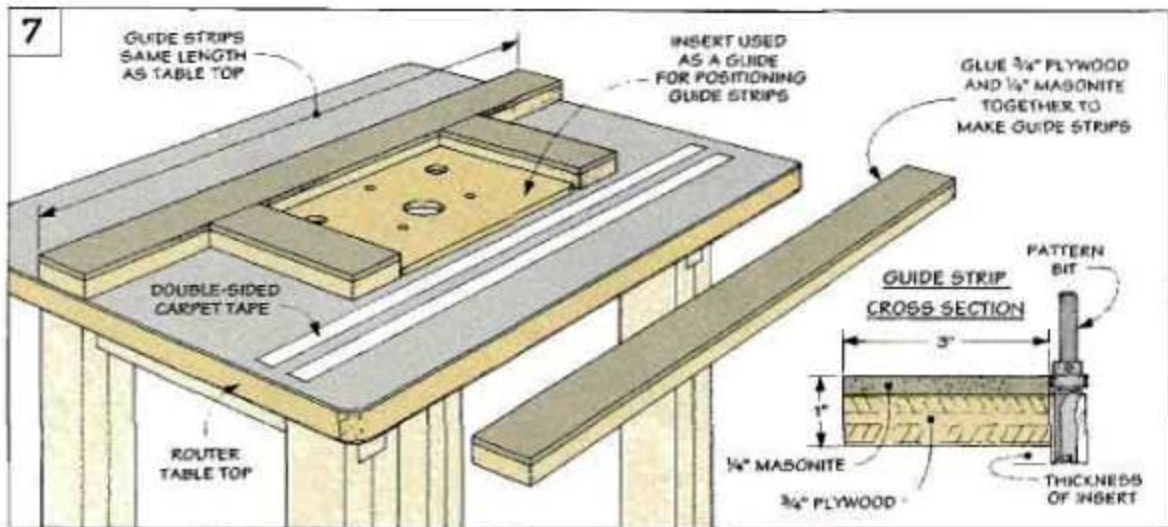

against, the guide strips need to be 1" thick, see Fig. 7.

The strips should be 3" wide to support the router. And two of the strips should long enough to match the width of the top. (They're used later for routing the miter slot, refer to Fig. 10.)

After sticking the guide strips down with double-sided carpet tape, lift the insert plate out.

**DEPTH OF CUT.** Before routing the lip you need to set the bit

depth to match the exact thickness of the insert plate.

To do this, mount the pattern bit in the router. Then place the insert plate on top of a guide strip, see Fig. 8. Set the router on top of the insert plate and lower the bit until it barely touches the top.

Remove the insert plate and rout out the recess lip, see Fig. 9. To improve the air flow to the router, rout a chamfer on the bottom of the opening, see Fig. 9a.



▲ Using a pattern bit in a router is a quick way to rout the recessed lip in the top. The bearing on the pattern bit rides against the guide strips and cuts a recess exactly the same size as the insert plate.

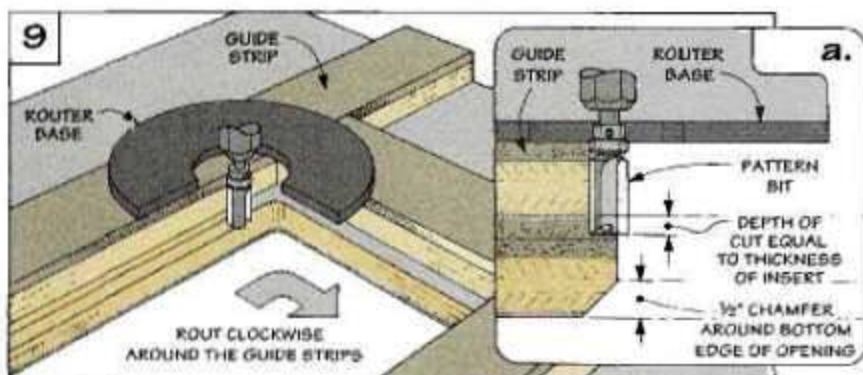
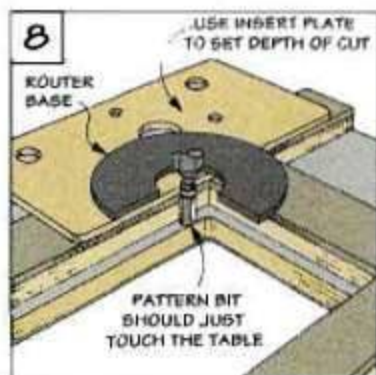

## Miter Gauge Slot

After completing the recess lip for the insert plate, there's only one thing left to do on the top — rout the miter gauge slot.

**GUIDE STRIPS.** Using double-sided carpet tape, position one of the guide strips 4" from the front edge of the top. This will form the

inside edge of the miter gauge slot, see Fig. 10a.

Now to position the other guide strip, hold the miter gauge snugly between the two strips, see Fig. 10.

**ROUT THE SLOT.** To set the depth of the pattern bit to rout

the slot, use a procedure similar to that shown in Figs. 8 and 9.

Place the miter gauge bar on top of the guide strip, and the router on top of the bar. Then lower the bit to barely touch the table top. Now remove the miter gauge and rout the slot, see Fig. 11.

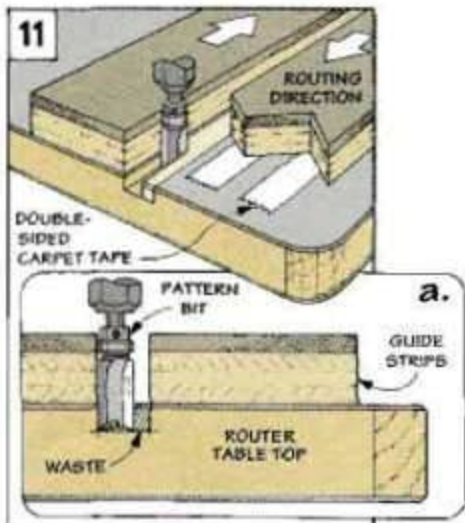
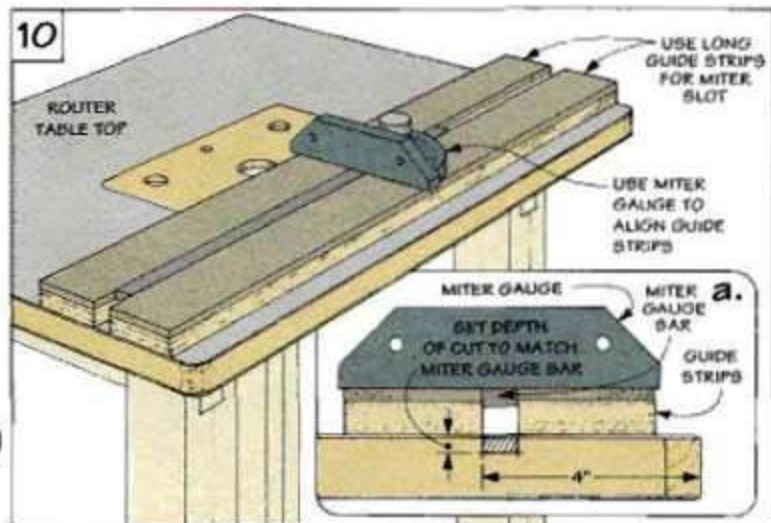

# Router Table Fence



**W**hether you build any other part of this router table, the fence is worth looking at. It has three unique features—a T-slot for accessories, a pair of sliding faces, and a special clamping system.

**T-SLOT.** The T-slot is designed

to accept T-shaped nuts that slide in and let you add a variety of accessories, including a guard, and a featherboard. (For more on this, see page 26.)

**SLIDING FACES.** The faces on the front of the fence slide open

so you can adjust the opening to fit the router bit you're using.

**CLAMPING SYSTEM.** The fence is also designed to adapt to any table (even one you already own). The built-in clamp heads on each end (that secure the fence to the table) can easily be adapted to fit almost any table top.

## EXPLODED VIEW

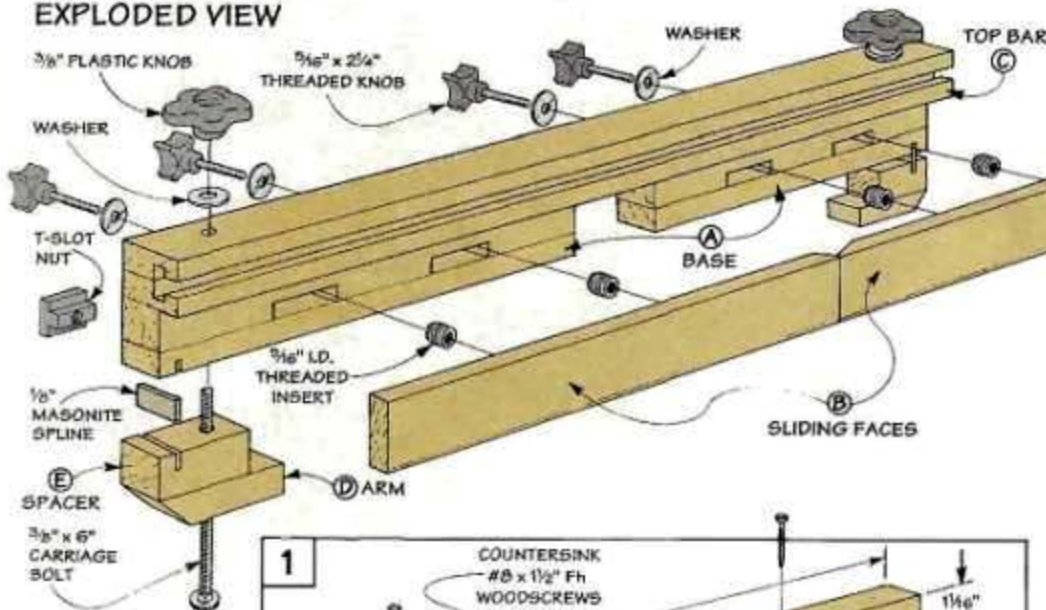

## BUILDING THE FENCE

The fence is made up of four sections. The split base (A) serves as a platform for adding the top bar (with the T-slot), the sliding faces, and the clamp heads.

The base is eventually cut in half to fit around the router bit, refer to the Exploded View. But it starts out as a long strip that consists of two pieces, a *bottom piece*, and a *top piece* with four dadoes cut in it, see Fig. 1.

The idea is to sandwich these two pieces together to form a base with four slots. (Knobs pass through the slots to hold the sliding faces in place, refer to Exploded View.)

To determine the length of these base pieces, measure the length of the router table top (30") and add 6". This allows 3" on each end for the clamp heads.

After the two base pieces are cut to length, cut dadoes (slots) in the top piece. Spacing the dadoes equally from the ends, see Fig. 1.

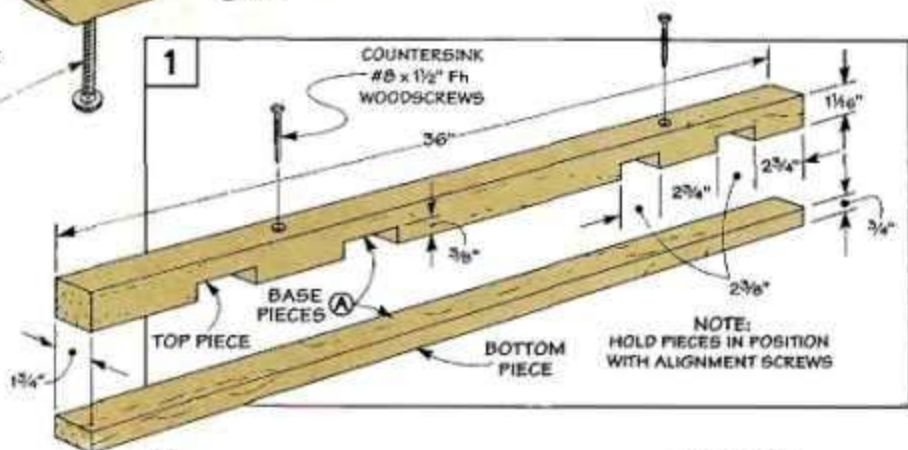

**ASSEMBLY.** Now glue the two base pieces together. Since glued surfaces tend to slide as they're clamped together, I used a simple technique to keep them aligned.

First, align the edges of both pieces and dry-clamp them together. Then screw the pieces together with a couple of wood screws, see Fig. 1.

Now remove the clamps, apply glue, and screw the pieces back together. The screws will automatically realign the pieces and keep them from sliding as the clamps are tightened.

### SLIDING FACES

Later, the *base* will be cut into two sections (to create an opening for the router bit). But for now leave it as one piece and add the *sliding faces* (B).

Each sliding face is one half the length of the base (18"). And the width (height) of each face is  $\frac{1}{16}$ " less than the height of the base, see Fig. 2. This creates clearance so the sliding faces won't bind against the top bar.

To allow the sliding faces (B) to

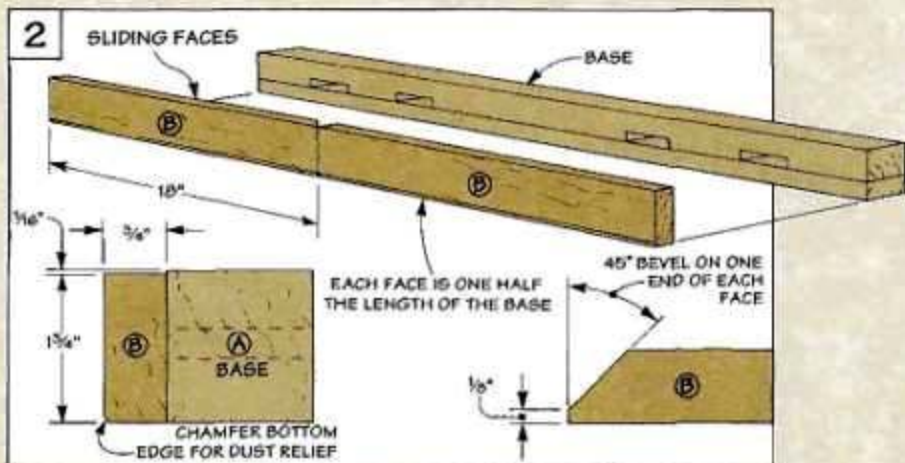

get as close as possible to the router bit, I beveled one end of each piece. I also routed a small chamfer along the bottom edge of both faces. This chamfer serves as a relief for sawdust, see Fig. 2.

**THREADED INSERTS.** The sliding faces are almost complete — all that's left is to install the threaded inserts.

The problem is making sure the threaded inserts align with the slots in the base. To do this, hold the sliding faces in the closed position and flush to the bottom

of the base. Then use an awl to scribe the position of the slots on the back of the faces, see Fig. 3.

With the slots located, you can drill holes for the threaded inserts. Center the holes between the scribed lines and near the end of each slot closest to the bevel, see Fig. 4.

Note: The hole needed for most  $\frac{5}{16}$ " I.D. threaded inserts is  $\frac{5}{8}$ "-deep. Be careful not to drill too deep, see Fig. 4a.

Finally, install the threaded inserts in the faces, see box below.

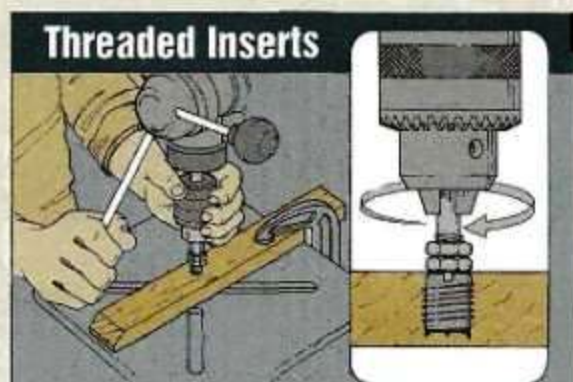
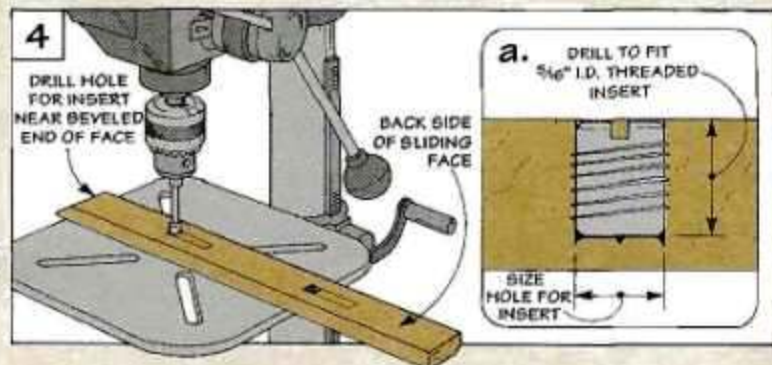
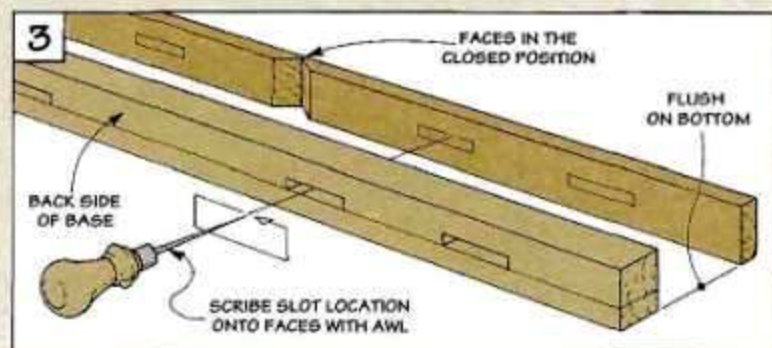

I use my drill press to install threaded inserts, straight and square into the workpiece.

Start by sawing off the head of a bolt that fits the insert. Then thread two nuts and the insert on the end of this bolt, and tighten the nuts against the insert.

Now, mount the bolt in the chuck, and using the control arm, press the insert down into the hole while rotating the chuck *by hand*.

## Top Bar

The base of the fence is just a platform for adding the top bar (and the clamps). The *top bar (C)* has a T-slot which is actually a system for adding all the accessories shown on pages 26 and 27.

**MAKE THE BAR.** The first step is to cut two pieces to size to make the bar, see Fig. 5. The length of each piece is the same length as the base (A) (36"). And the width of each piece (2½") equals the width of the base, plus the sliding face (B) pieces, refer to Fig. 6a.

**CUT THE SLOT.** After cutting the pieces to size, the next step is to make the T-slot. Cutting the T-slot is a two-step operation.

Start by cutting a ⅜" by ⅜" groove in the face of each piece, see Step 1 in Fig. 5.

Then turn each piece on edge and trim ¼" off the end of the "tongue" formed by the groove, see Step 2 in Fig. 5.

**GLUE-UP.** By gluing these two pieces together, a T-slot is formed in the top bar, see Fig. 6a.

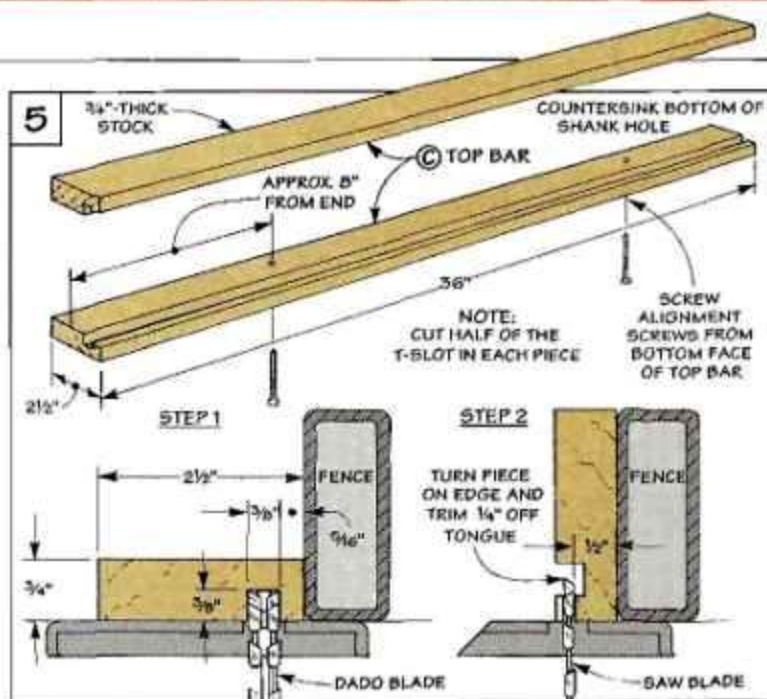

Here again I used the screw and glue technique (mentioned on the previous page) to glue these pieces together. To keep the heads of the screws from showing, screw them in from the *bottom* face of the top bar.

**GLUE TOP BAR TO BASE.** The next step is to glue the top bar (C) to the base (A).

To help align the pieces, temporarily attach the sliding face pieces (B) to the base (A) with knobs (or bolts), see Fig. 6a.

Then, to make sure that the top bar and the base are flush and square, clamp them together (no glue yet) on a flat surface (I used my saw table), see Fig. 6.

Once again, use the screw and glue technique, this time screwing from the bottom of the base into the top bar.

After the glue has dried, remove the screws and the sliding face pieces you temporarily attached to the base.

**BIT OPENING.** Now that the base is attached to the top bar, the next step is to cut an opening for the router bit.

The opening is 4" wide, and centered on the length of the fence, see Fig. 7.

I cut the opening on the table saw by setting a dado blade slightly less than the height of the base, see Fig. 7a. Then I made repeated passes to waste out the stock for the bit opening.

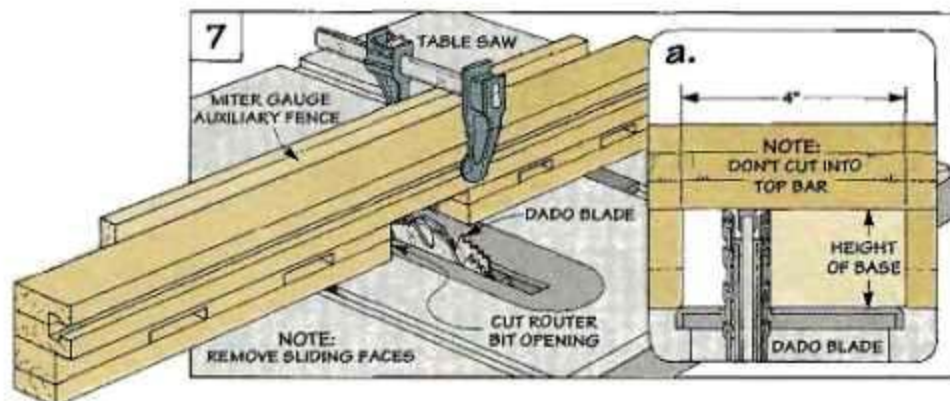
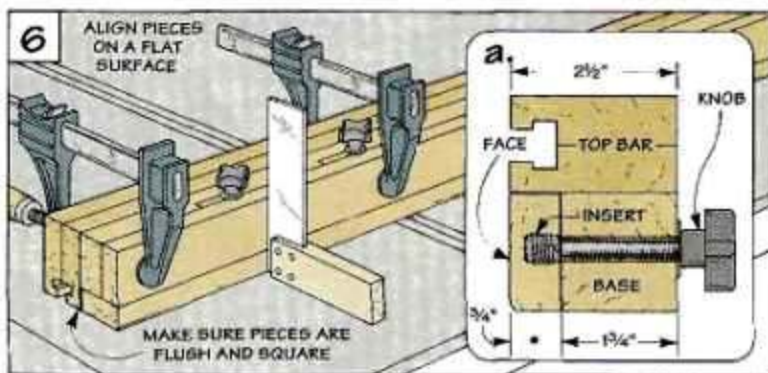



# Clamp System

The fence is almost complete, all that's left is the clamp system.

**CLAMP SYSTEM.** What makes this clamp system work is a carriage bolt that passes through the *clamp head* and up through the fence. By tightening a knob (or wing nut) on the bolt, the clamp head pinches against the bottom of the table top, holding the fence in place, see Fig. 8a.

**THE CLAMP HEAD.** Each clamp head consists of two pieces — a *spacer* that's slightly thinner than the top, and an *arm* that extends under the table top.

The clamp heads are "hinged" to the fence with Masonite splines, see Fig. 8. The only requirement is to cut matching kerfs in the spacer and the fence.

To cut these kerfs safely, I glued the spacers to a long arm blank first. (Later, I cut the arm blank in half to make two clamp heads, see Fig. 9.)

**ARM BLANK.** To make the *arm blank* (D), cut an 8"-long blank to

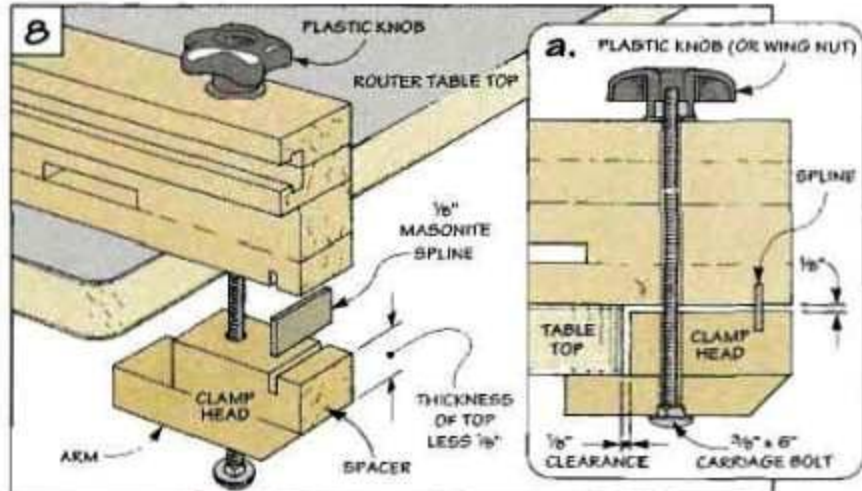

the same width as the router fence base (A) ( $1\frac{3}{4}$ "), see Fig. 9.

**SPACERS.** Next, determine the thickness of the *spacers* (E) by measuring the thickness of your router table top. Then, for clearance, subtract  $\frac{1}{8}$ ". (This creates a space so the arm can pinch against the table top, see Fig. 8a.)

To determine the length of the spacers, center the fence from

side-to-side on the table top. Then measure the amount of overhang on each side ( $3$ ") and subtract  $\frac{1}{8}$ " for clearance ( $2\frac{7}{8}$ ").

Now cut two spacers (E) to these dimensions, and glue them to the arm blank (D), see Fig. 9.

**SPLINE HINGES.** The next step is to cut kerfs for the  $\frac{1}{8}$ " Masonite splines, see Fig. 9.

To align the pieces, use the rip fence on the table saw to position kerfs in the bottom of the fence, and then, without changing the set-up, cut kerfs in the spacers.

Now, cut Masonite splines  $\frac{1}{8}$ " wider than the combined depth of the kerfs ( $\frac{7}{8}$ "). And finally, before cutting the blank in half, I cut bevels on the ends (for appearance), see Fig. 9.

**CARRIAGE BOLTS.** These clamp heads are attached to the fence with carriage bolts.

The easiest way to get the holes to align in these two pieces is to fasten the clamp heads to the fence with carpet tape, and drill through both pieces, see Fig. 10.

**ShopTip:** If your drill bit isn't long enough, drill as far as you can, remove the clamp heads and complete the hole, see Fig. 10a.

**FINISH.** Before assembling the fence, I applied two coats of tung oil finish to keep the wood parts from getting soiled.

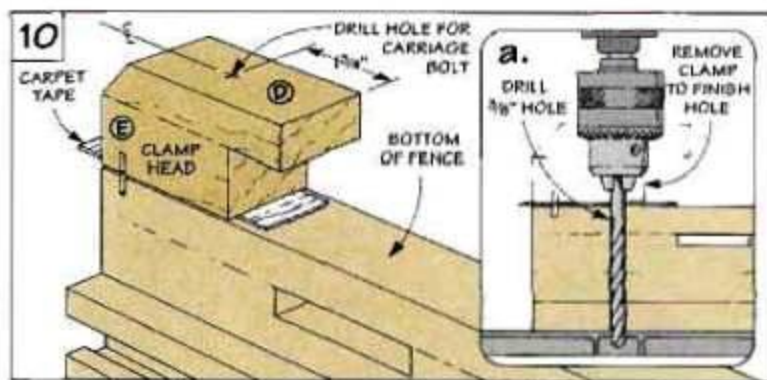
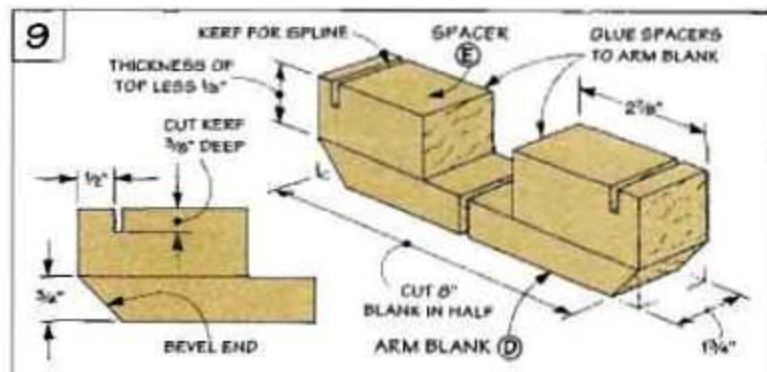

# Fence Accessories

## Router Bit Guard



■ For safety, you should include a bit guard on the router table. This one is designed to attach to the fence with T-nuts and threaded knobs.

The guard is made of two pieces: a  $\frac{1}{2}$ "-thick hardwood back piece, and a Plexiglas shield.

To make the guard, first cut the back to size, and cut two  $\frac{1}{2}$ " slots for adjusting the height.

The shield is cut from  $\frac{1}{4}$ "-thick Plexiglas, and screwed to the back. This whole assembly is simply attached to the fence with threaded knobs, see Fig. 2.

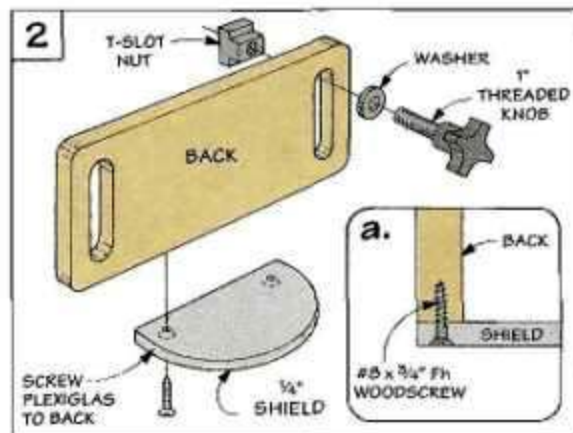
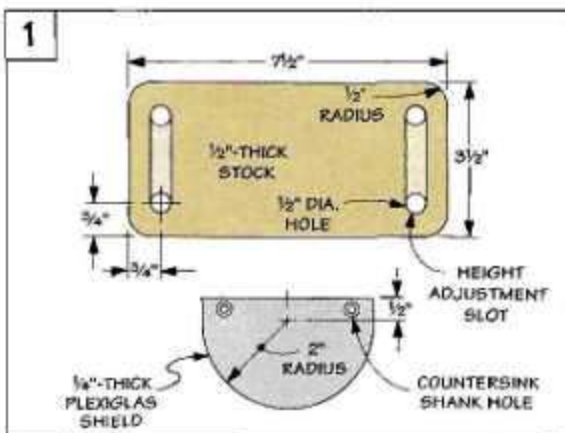

## Guard for Freehand Routing



■ When you want to do freehand routing, you need a guard that extends out from the fence. This one is made from a single piece of  $\frac{1}{4}$ "-thick Plexiglas, see Fig. 1.

To stabilize the guard, two sets of notches are cut. Two straight notches are cut on the back edge.

And two  $45^\circ$  notches are cut in the sides, see Fig. 1.

To install the guard, turn the fence over and pinch the sliding faces against the guard, see Fig. 2. Then install the screws.

To remove the guard, simply open the faces and pull it out.

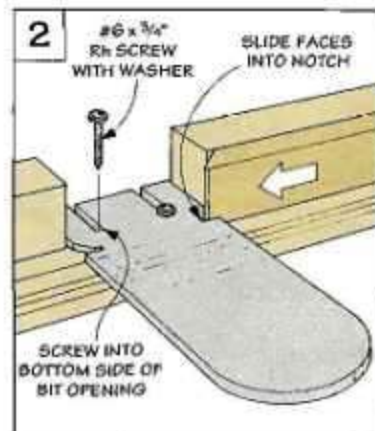
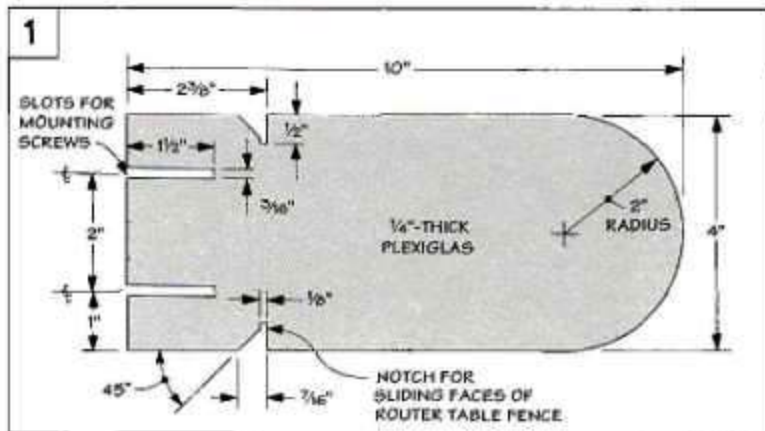

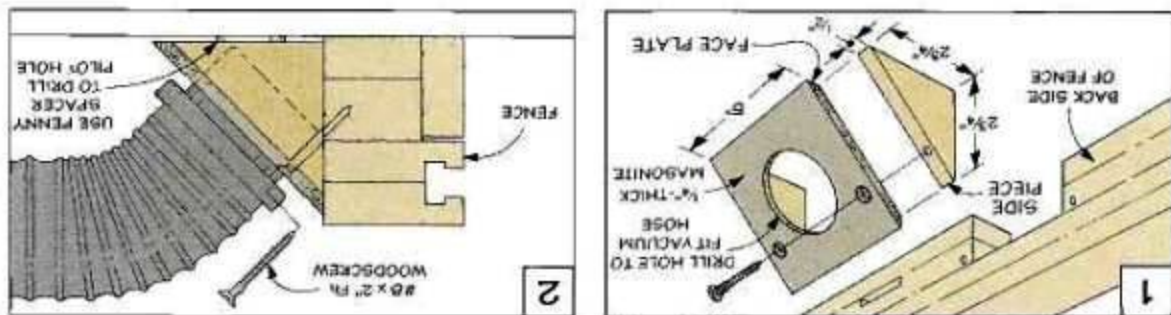

Here's an easy-to-build dust collection system that screws to the back of the fence (over the router bit opening) and connects



to your shop-vac, see photo. To build the attachment, cut two triangular-shaped side pieces from  $\frac{1}{2}$ "-thick stock, see Fig. 1. **TOP PLATE.** Next, make a face plate from  $\frac{1}{4}$ " Masonite. It's 5" wide and beveled on the top and bottom edges to match the side pieces, see Fig. 2. (This allows the attachment to fit tight against the fence and the table.) Now drill a hole in your vacuum

hose will fit snug, see Fig. 2. Glue the pieces together and then screw the attachment to the back of the fence. **PROBLEM.** As you're driving in the screws, the bottom of the vacuum attachment is forced down and tends to lift the fence. To get around this, put pennies under the side pieces before starting the screws. After they're started, remove the pennies and finish tightening the screws.

## Vacuum Attachment

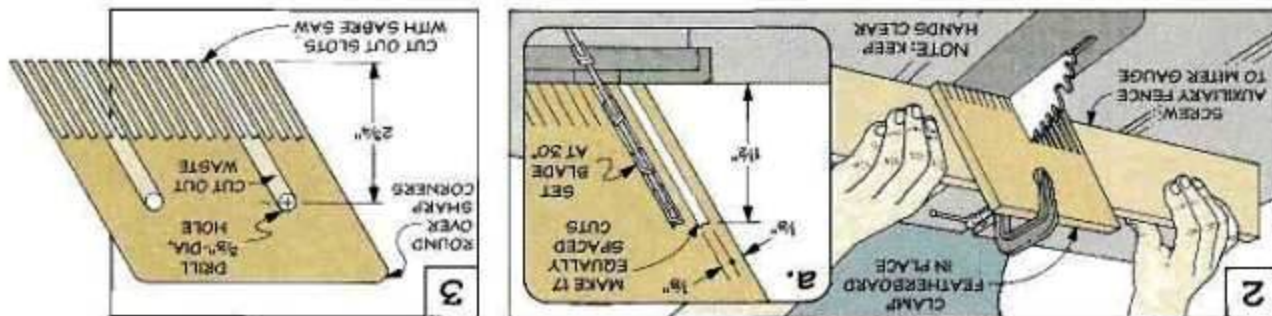

A featherboard is helpful for keeping boards tight against the table for a consistent cut. To make this one, cut a work-piece from  $\frac{1}{2}$ "-thick stock with both ends cut at  $30^\circ$ , see Fig. 1.

gers, attach a tall auxiliary fence to your miter gauge, see Fig. 2. Now, tilt the table saw blade to  $30^\circ$  and raise it to make a  $1\frac{1}{2}$ " high cut, see Fig. 2a. Once the blade height is set, make 17 equally spaced cuts. (This leaves 18 fingers.) **CUT THE SLOTS.** The last step is to make two slots for attaching the featherboard to the fence. To make the slots, drill  $\frac{3}{8}$ " holes,  $2\frac{3}{4}$ " up from the bottom edge of the featherboard. Then, cut out the slots with a sabre saw or band saw, see Fig. 3.



## Featherboard

# Shop Solutions

## Sanding Block



■ Here's a different twist, a sanding block that uses a belt from a belt sander. (I made mine to fit a 3" x 21" belt, but it can be modified to fit any belt.)

The sanding block is actually

two pieces, a body and a heel with springs in between, see photo. Dowels are glued into the heel to hold the springs in place. When the heel and body are squeezed together, a sanding belt can be slipped over the block. The springs push the pieces apart to tension the belt, refer to Fig. 2.

To make a sanding block for a 3" x 21" belt, cut a 2x4 blank the same width as the belt (3") and 8 $\frac{3}{4}$ " long. Then, drill the holes for the dowels, see Fig. 1. (It's easi-

est to drill these holes before cutting off the heel.)

To help tension the belt, I rounded over the edges of the heel and beveled the other end, see Fig. 2. Finally, cut off the heel and glue the dowels into it.

To use the block, slide springs on the dowels and insert the dowels into the body. Then compress the springs and slip on a sanding belt. When you need a fresh surface, squeeze the block together and rotate the belt.

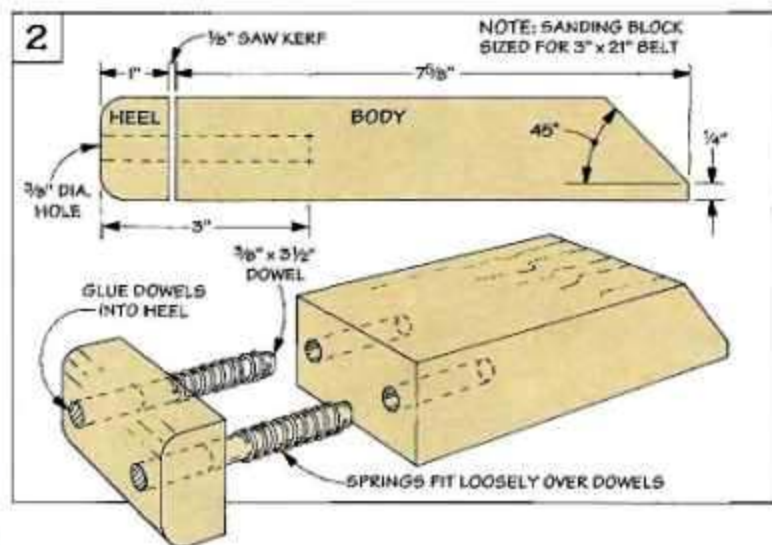
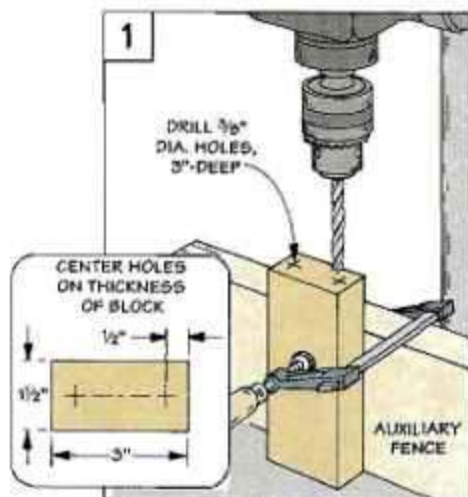

## Woodscrew Tip

When screwing two pieces of wood together, the threads can pull up the grain between the pieces. This prevents the pieces from being drawn tightly together.



■ Sometimes the threads of a screw can raise the wood fibers between two pieces, causing a gap, see photo at left.

Typically, you can avoid this by clamping the pieces together. But what if you can't clamp them?

One solution is to create a

"pocket" for the raised fibers. It's easy to do this by countersinking the *inside* face of either the shank hole or the pilot hole see Figs. 1 and 2. Note: The only drawback to countersinking the pilot hole is it reduces the holding surface for the screw threads.

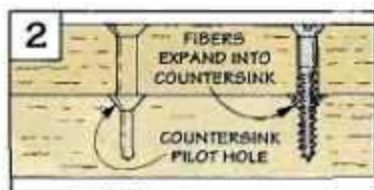
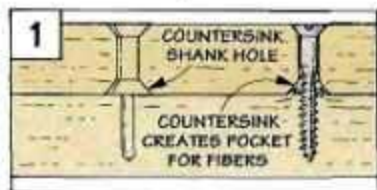

## Sawhorse Tray

■ A tray between the legs of a sawhorse is a good idea. The only problem is if you add a tray, you won't be able to stack your sawhorses on top of each other.

But here's a way to have your tray and stack it, too — make a fold-up tray, see drawing at right. It works like this: a pair of 3"-long roundhead screws act as pivot points on each end of the tray, see Detail in drawing at right. The other side of the tray is supported by a light weight chain suspended from the top rail.

The tricky part is making sure the tray will clear the top rail when one sawhorse is stacked on top of another.

The way to solve the problem is to locate the pivot point of the tray halfway up the leg. Then to find the overall width of the tray, measure the distance between the pivot point and the top rail, and subtract 1" for clearance.

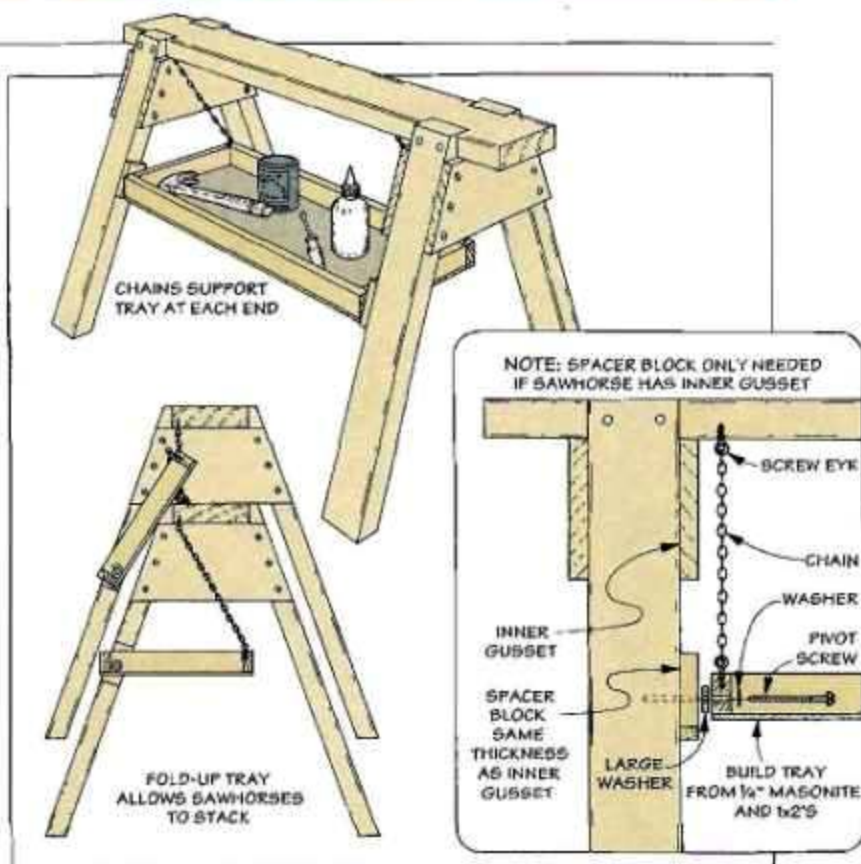

## Pipe Clamp Rack

■ It's hard to imagine a rack for pipe clamps that's easier to make than this. It's made from a length of 2x4 and broom handle clips from a hardware store.

I screwed the clips to the 2x4 spacing them 8" apart, see drawing. Then screw the 2x4 to the wall. The pipe clamps snap in the clips and the heads of the clamps rest on the 2x4.

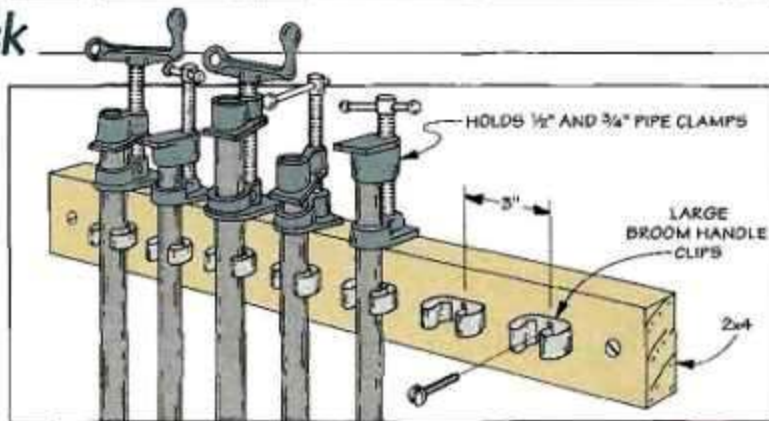

## Drill Press Magnet



■ When using the drill press it seems that I'm always looking for a misplaced bit, countersink, or chuck key. But a trip to the local hardware store solved all that.

I purchased a 12"-long magnetic tool bar (it's just a long bar magnet). The tool bar holds itself to the metal head of the drill press. And keeps my drill bits and accessories handy, see photo.

## Send in Your Solutions

Finding solutions to problems is a part of woodworking. If you'd like to share solutions to problems you've faced, send them to: *ShopNotes*, Attn: Shop Solutions 2200 Grand Ave., Des Moines, IA 50312.

We'll pay upon publication up to \$200 depending on the published length. Please send an explanation along with a photo or sketch.

# Book Review

**A** new book, *The Workshop Book* by Scott Landis, just came across my desk. Naturally, I was curious to get a close-up view of all the professional and home workshops that Landis visited while working on his book.

**AN IDEA BOOK.** *The Workshop Book* is crammed with hundreds of practical and creative ideas for tool and lumber storage, shop-made tools, jigs and safety accessories, shop location, and layout. Some of the ideas can be lifted right out of the book. Others can be adapted to fit your situation.

One story I found particularly interesting was about Mark Duginske, a woodworker from Wisconsin. Duginske found a creative solution to the space limitations of a single car garage shop. He sliced the garage in half, rolled one half to a concrete pad, and then filled in the open space with walls, windows, and a roof.

**A RANGE OF IDEAS.** Maybe what makes Landis' book so appealing is there are usable ideas for a whole range of woodworkers. For example, Landis describes dust collection systems that range from a Sears shop vacuum, to a shop-built system costing \$250, to a very elaborate sys-

tem that compresses sawdust into bricks that are burned to heat the shop.

## SPACE-SAVING IDEAS

If lack of space is a problem (are there any shops where it isn't?), you might get a few pointers from Aldren Watson. Watson set up his shop in a laundry room. Obviously limited in the number of power tools he can have, he manages with just a fold-out benchtop, a band saw with infeed/outfeed supports, and still has adequate storage space for all his tools and jigs.

Landis describes lots of working shops that have been shoehorned into closets, attics, and pantries. The important thing is these space-saving shops offer information that you can use in your own shop, no matter what size.

## SHOP LAYOUT

While most of us don't have lots of shop space, we can learn something from the more fortunate woodworkers who do. Take a look at Kelly Mehler's shop in Berea, Kentucky. He has reclaimed 3200 square feet from an old auto dealership.

With all of that space, it's hard to imagine anyone having to worry about shop layout. But Mehler does. His bench doubles as an

outfeed table for the table saw. And the table of his overarm router also adjusts to the same height if he needs more support.

**DETAILS.** Clustering work surfaces to get the maximum use of space and tools may seem like a minor detail. But it's details like these that make a shop work. It's also the kind of attention to detail

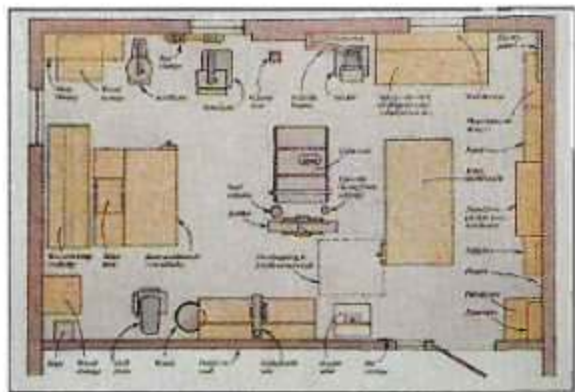

▲ Detailed plans like these are used throughout the book. Along with large color photographs of unique shops and space-saving solutions.

that Landis shows throughout *The Workshop Book*.

Landis has included over a dozen color floor plans of shops. Everything is labeled: the location of machinery, tools, storage, and sharpening areas. You'll also find large, full color photographs throughout the book that show enough detail so you can model your own ideas after them.

The only problem is it may be difficult to build some of the shop projects since they're not shown in a step-by-step fashion. But this is an "idea" book, not a "how-to" manual. If you're looking for a tour of great shops, and lots of ideas, *The Workshop Book* will fit the bill.

(Photos reprinted from *The Workshop Book* by Scott Landis, ©1991 by The Taunton Press. Used with permission.)

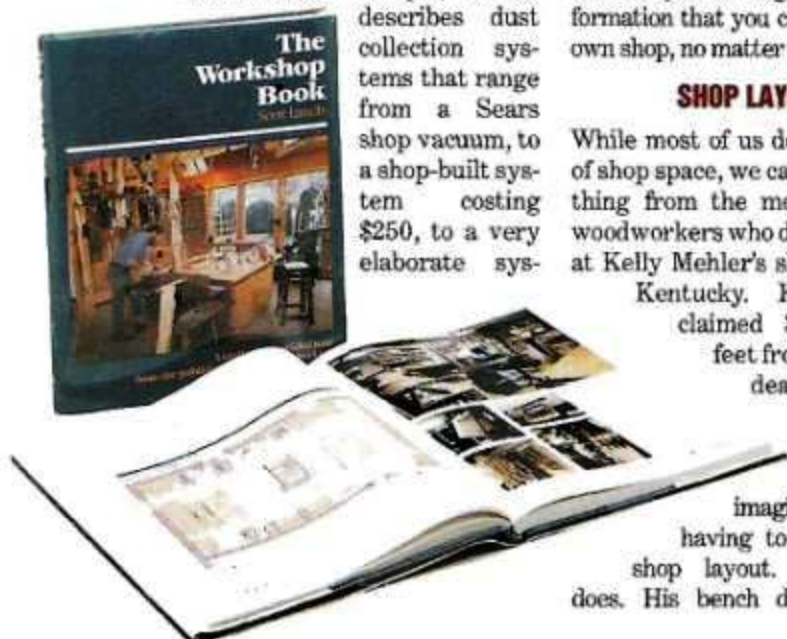

# Sources

**ShopNotes Project Supplies** is offering a variety of hardware kits and manufactured items for the Router Table.

We've also put together a list of other mail order sources that carry the same or similar items.

## ROUTER TABLE TOP

The following items are available from **ShopNotes Project Supplies** for the Router Table Top.

**FORMICA.** Two sheets of white Formica, for the top, oversized to trim to final size (24" x 32").

**3018-105 Formica**.....\$26.95  
The metal mounting brackets used to attach the top to the base, (4) needed.

**6801-110 Mounting Bracket**  
with screws .....\$35.00

**INSERT.** The 1/4"-thick phenolic insert for the Router Table Top comes pre-drilled with a 1 3/4" opening for the bit, and two 1" finger holes. The corners are rounded and the edges chamfered. This insert is 7 3/4" wide (deep) and 11 3/4" long and will fit most routers.

**4502-229 Phenolic Insert for Router Table**.....\$15.95

**OVERSIZED BLANK.** We're also offering an oversized phenolic blank for use with larger routers. Note: This blank is *not* drilled, or routed. You must cut it to shape.

**4502-245 11" x 15" Phenolic Blank**.....\$13.95

## ROUTER TABLE FENCE

A kit is available that contains all of the hardware (but not the wood) for

the router table fence. The kit includes the following hardware:

- (2) 3/8" x 6" Carriage Bolts
  - (2) 3/8" Star Knobs
  - (2) 3/8" Washers
  - (4) 5/16" I.D. Threaded Inserts
  - (4) 5/16" x 2 1/4" Star Knobs
  - (2) 5/16" x 1" Star Knobs
  - (6) 5/16" Washers
  - (2) 5/16" T-slot Nuts
- 6801-200 Router Table Fence Hardware Kit**.....\$18.95

## CABINET KIT

If you want to build the enclosed cabinet shown in the special plans inserted in this issue, a hardware kit is available. The kit includes:

- (2) 1 1/2" x 32" Piano Hinges
  - (2) D-handle Pulls
  - (2) Magnetic Catches
  - (4) Mounting Brackets
  - (4) 3/8" x 1 1/2" Lag Screws
- 6801-150 Cabinet Kit**.....\$14.95

## ACCESSORIES

The Accessories shown on pages 26 and 27 are also available as manufactured versions.

**BIT GUARD.** This is a one-piece guard made from 1/4"-thick optic orange Plexiglas. Slots are cut and it's bent to a right angle. (Note: If you don't order Fence Kit 6801-200, the Bit Guard requires Attachment Kit 6801-250.)

**4502-206 Bit Guard**.....\$15.95

**FEATHERBOARD.** We're offering a featherboard made from 3/8"-thick polycarbonate. (Note: If you don't order Fence Kit 6801-200, the

featherboard requires Attachment Kit 6801-250.)

**4502-525 Featherboard**.....\$14.95  
**FREEHAND GUARD.** This guard is made from optic orange Plexiglas with flame polished edges. Mounting screws are included.

**6801-220 Freehd. Guard**.....\$15.95  
**DUST HOOD.** The dust collection hood is made from black ABS plastic and fits a 2 1/4" shop-vac hose.

**6801-230 Dust Hood**.....\$12.95

## ATTACHMENT KIT

Special kit for attaching Guard and Featherboard, includes (2) T-slot nuts, and (2) threaded knobs and washers.

**6801-250 Attachment Kit**... \$9.95

## COMPLETE ROUTER TABLE KIT

A kit is available that includes all of the hardware needed to build the Top, Fence, and Cabinet (laminated not included). Also includes the four accessories, see Accessories heading. However, no wood is included.

**6801-300 Complete Kit**.....\$99.00

## ELU ROUTER

The model #3338 router can be found at Elu dealers and from some of the mail order sources listed below.

## THE WORKSHOP BOOK

This book is available through Taunton Press and several of the mail order catalogs listed below.

*The Workshop Book* by Scott Landis is also available through **ShopNotes Project Supplies**.

**2004-155 Workshop Book**..\$34.95

## MAIL ORDER SOURCES

Similar hardware and supplies may be found in the following catalogs. Please call each company for a catalog or for ordering information.

### Constantine's

800-223-8087  
Mounting Brackets

### Highland Hardware

800-241-6748  
Elu 3338, Insert Material, Hardware

### Taunton Press

800-888-8286  
The Workshop Book

### Tool Crib

800-358-3096  
Elu 3338

### Trend-Lines

800-767-9999  
Hardware, Phenolic

### Williams Tool

800-788-0007  
The Workshop Book, Insert Material

### Woodcraft

800-225-1153  
The Workshop Book

### The Woodsmith Store

515-255-8979  
Elu 3338

### The Woodworkers' Store

612-428-2199  
Plastic Knobs, Mounting Brackets, The Workshop Book

### Woodworker's Supply

800-645-9292  
Hardware, The Workshop Book

### ShopNotes Supplies

800-444-7527  
The Workshop Book

## ORDER INFORMATION

### BY MAIL

To order by mail, use the form enclosed with a current issue. The order form includes information on handling and shipping charges, and sales tax. Send your mail order to:

**ShopNotes  
Project Supplies  
P.O. Box 842  
Des Moines, IA 50304**

### BY PHONE

For fastest service use our Toll Free order line. Open Monday through Friday, 8:00 AM to 5:00 PM Central Time.

Before calling, have your VISA, MasterCard, or Discover Card ready.

**1-800-444-7527**

Note: Prices subject to change after April 1, 1992.



## Scenes From the Shop

*In most shops you can find an interesting collection of tools and supplies tucked away in a corner, or stacked on a shelf. Looking through such a collection can create*

*images of past projects. And upon closer inspection it can even reveal a bit of the shop's history — and perhaps, some insight into the craftsman who works there.*





# Router Table CABINET

**R**outer tables are one of the most valuable tools in the workshop... but they have two drawbacks. They're noisy, and they create a lot of sawdust. As we were working on the new Router Table shown in *ShopNotes* No. 1, we built an enclosed base to solve both of these shortcomings.

**CLEAN AND QUIET.** It's amazing how much an enclosed base quiets down a router. The noise reduction makes it a lot more comfortable to work around. And by adding a removable dust box inside, you substantially reduce the dust and chip mess.

The only problem with enclosing a router in a cabinet is heat. To allow for cool air flow through the cabinet, we cut vents in the side and the back.

**BIT HOLDERS.** Enclosing a router base to reduce noise and sawdust is great, but my favorite feature of this cabinet is something you won't see until you open the doors. Screwed to the insides of the doors are a set of unique router bit holders that won't fill with dust and chips.

**SUPPLIES.** I used one sheet of maple plywood for the case (you could also use birch), and maple for the trim. *ShopNotes Project Supplies* has a complete hardware kit for this cabinet, see Sources on page 31 of issue No. 1.



A Supplement to ShopNotes

Copyright 1992 Woodsmitth Corporation  
2200 Grand Avenue, Des Moines, IA 50312

## EXPLODED VIEW

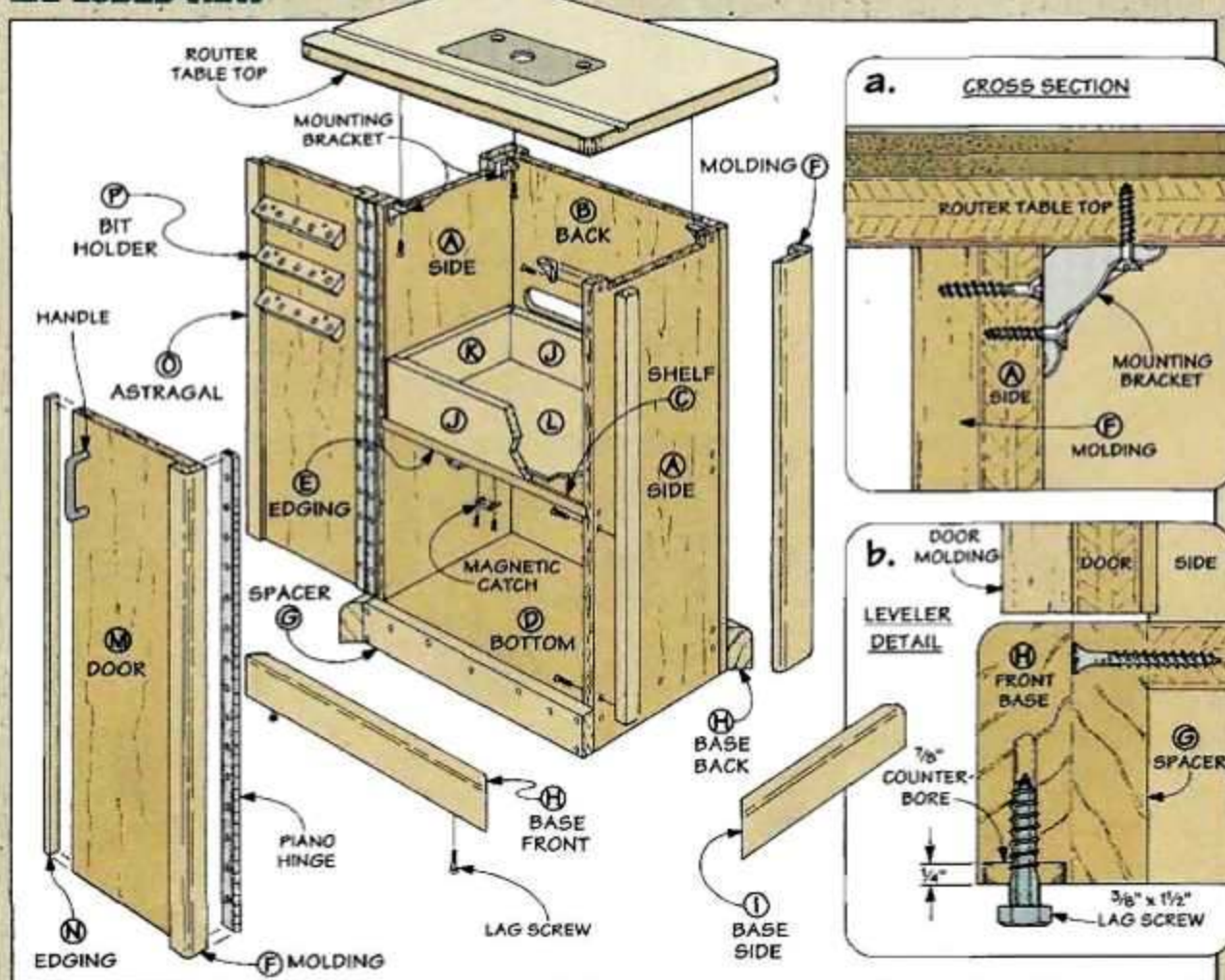

## MATERIALS

### CABINET

A Sides (2)	$\frac{3}{4}$ ply - 14 $\frac{13}{16}$ x 35
B Back (1)	$\frac{3}{4}$ ply - 23 $\frac{1}{2}$ x 35
C Shelf (1)	$\frac{3}{4}$ ply - 14 $\frac{5}{16}$ x 22 $\frac{1}{2}$
D Bottom (1)	$\frac{3}{4}$ ply - 14 $\frac{13}{16}$ x 22 $\frac{1}{2}$
E Edging (1)	$\frac{1}{2}$ x $\frac{3}{4}$ - 22 $\frac{1}{2}$
F Molding (4)	1 $\frac{1}{2}$ x 3 - 31 $\frac{1}{2}$

### BASE

G Spacer (1)	1 $\frac{5}{16}$ x 3 $\frac{1}{2}$ - 23 $\frac{1}{2}$
H Frt./Bck. (2)	1 $\frac{1}{16}$ x 3 $\frac{1}{2}$ - 25 $\frac{5}{8}$
I Sides (2)	1 $\frac{1}{16}$ x 3 $\frac{1}{2}$ - 16 $\frac{15}{16}$

### DUST BOX

J Frt./Bck. (2)	$\frac{3}{4}$ ply - 5 x 22
K Sides (2)	$\frac{3}{4}$ ply - 5 x 14
L Bottom (1)	$\frac{1}{4}$ ply - 13 $\frac{1}{2}$ x 21

### DOORS

M Doors (2)	$\frac{3}{4}$ ply - 11 $\frac{3}{16}$ x 31 $\frac{3}{8}$
N Edging (2)	$\frac{1}{2}$ x $\frac{3}{4}$ - 31 $\frac{3}{8}$
O Astragal (1)	$\frac{3}{16}$ x $\frac{7}{8}$ - 31 $\frac{3}{8}$
P Bit Hldrs. (6)	$\frac{3}{4}$ x 1 $\frac{5}{8}$ - 10

### SUPPLIES

- (2) D-Handle pull
- (2) Mag. catch
- (2) 36" Piano hinge
- (4) Mt. Bracket
- (4)  $\frac{3}{8}$ " x 1 $\frac{1}{2}$ " Lag screw

## CUTTING DIAGRAM

1 $\frac{1}{16}$ " x 8" - 48" (TWO BOARDS @ 2.5 BD. FT.)



1 $\frac{3}{4}$ " x 4" - 72" (2 BOARDS @ 4 BD. FT.)



$\frac{3}{4}$ " x 4" - 72" (2 BD. FT.)



1 SHEET (48" x 96") OF  $\frac{3}{4}$ "-THICK MAPLE PLYWOOD

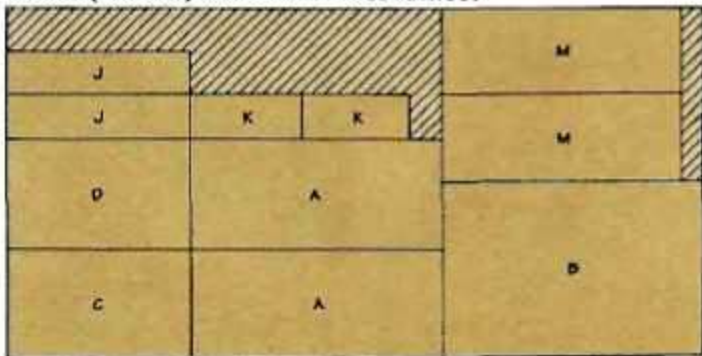

## CASE

The router cabinet is a plywood case with hardwood trim around the base and at the corners.

**CASE.** The case consists of five basic pieces: two sides, a shelf, a back, and a bottom. The doors are added later. (The top is shown in *ShopNotes* No. 1, page 18.)

Start by cutting two *sides* (A)

from  $\frac{3}{4}$ " plywood, see Fig. 1. Then, to join the shelf and bottom to the sides, cut  $\frac{1}{4}$ "-deep dados to match the thickness of the plywood you're using, see Fig. 1.

The next step is to cut a *back* (B), a *shelf* (C), and a *bottom* (D), see Fig. 1. The shelf (C) is cut  $\frac{1}{2}$ " narrower than the bottom so an

*edging strip* (E) can be glued on to cover the plywood edge.

**VENTILATION.** To prevent heat from building up inside the cabinet, cut a notch at the top of each side (A), and cut a slot in the back (B); see Figs. 1a and 1b. After cutting the vents, glue and screw the case together, see Fig. 2.

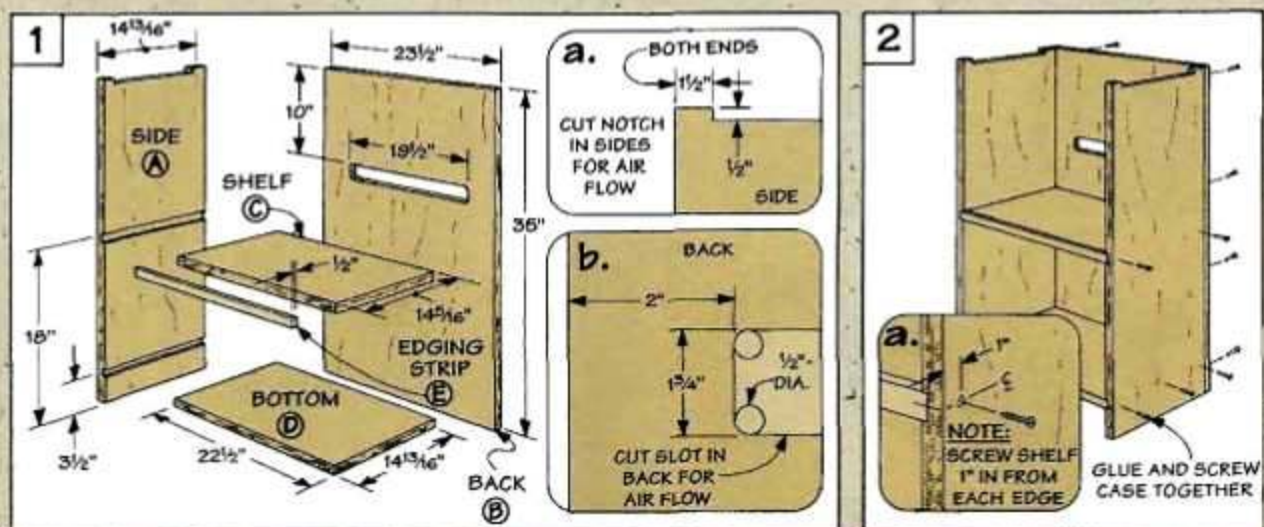

## BASE

After the case is assembled, work can begin on the base. The base consists of four pieces (H, I) that are screwed to the bottom of the case, see Fig. 3.

**SPACER.** Before I cut the base pieces to length, I glued and screwed a *spacer* (G) to the bottom front of the case, see Fig. 3. This strip is necessary so the base will protrude uniformly around the case after the cabinet doors are attached, see Exploded View.

**BASE PIECES.** After the spacer is screwed to the case, cut the *base pieces* (H, I) from  $\frac{5}{4}$  stock ( $1\frac{1}{16}$ " actual thickness)  $3\frac{1}{2}$ " wide and to rough length, see Fig. 3.

Then rout a  $\frac{1}{2}$ " round-over on the top edge of each piece. Next, miter the ends to fit around the bottom of the cabinet, and glue and clamp the base pieces in place. With the clamps still in place, drill shank holes and screw the base pieces to the cabinet.

**LEVELERS.** To compensate for uneven floors, I added four shop-made levelers to the front and back base pieces. The levelers are simply lag screws that fit in counterbored holes, see Detail B

in Exploded View on page 1.

I drilled  $\frac{7}{8}$ "-dia. counterbores so I could use a socket wrench to install and adjust the levelers. Then I drilled pilot holes for the lag screws.

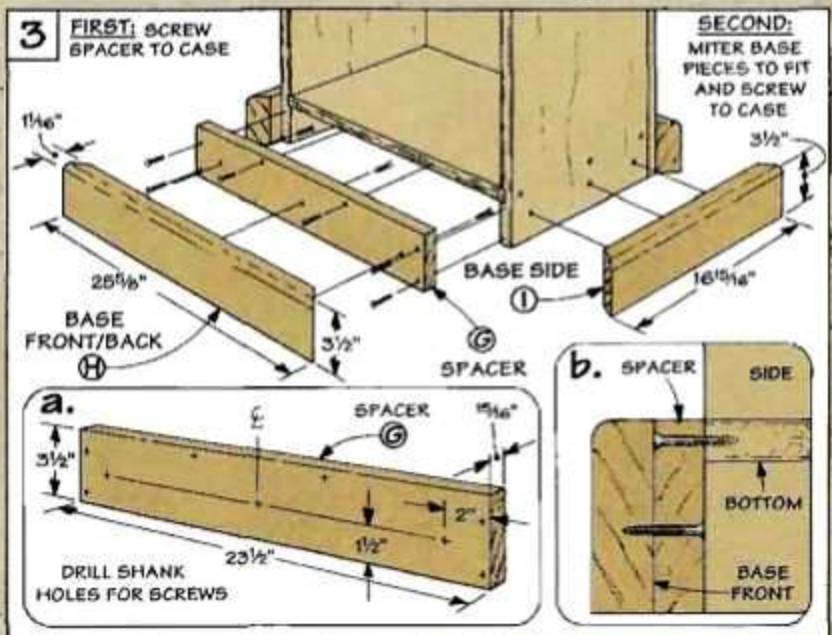

## MOLDING

The *molding strips (F)* that cover the plywood corners are cut from 1½"-thick hardwood. To determine their length, measure from the top of the base (I) to the top of the sides (31½"). Then cut four molding strips 3" wide and to the measured length, see Fig. 4.

Next, rout a ½" round-over on three corners of each strip, see Fig. 4b. Then remove the last corner by cutting a large rabbet, see Figs. 4b and 5.

**ATTACH MOLDING.** The two strips for the back can be glued and screwed in place, see Fig. 4a.

But the two molding strips on the front actually wrap around the doors. I simply ripped the strips along their length, and attached one strip to the cabinet sides, see Fig. 6. (The corner section is glued to the door later.)

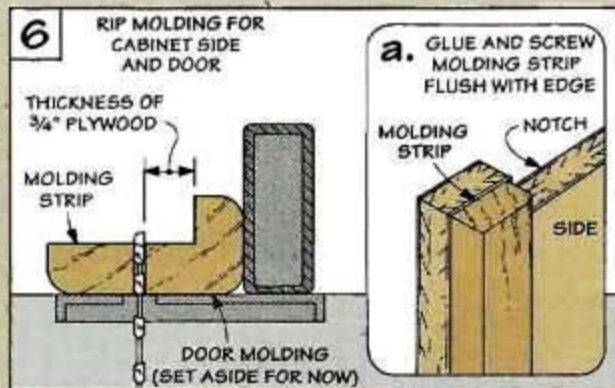
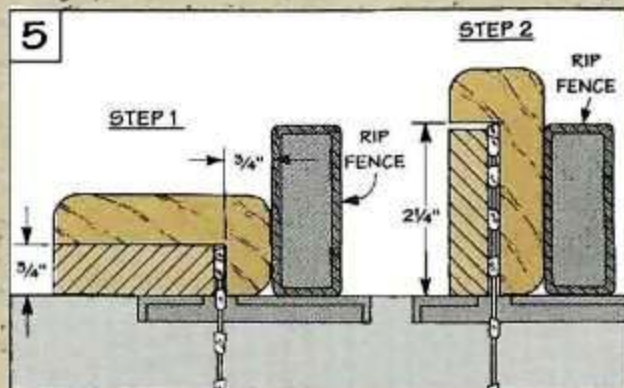
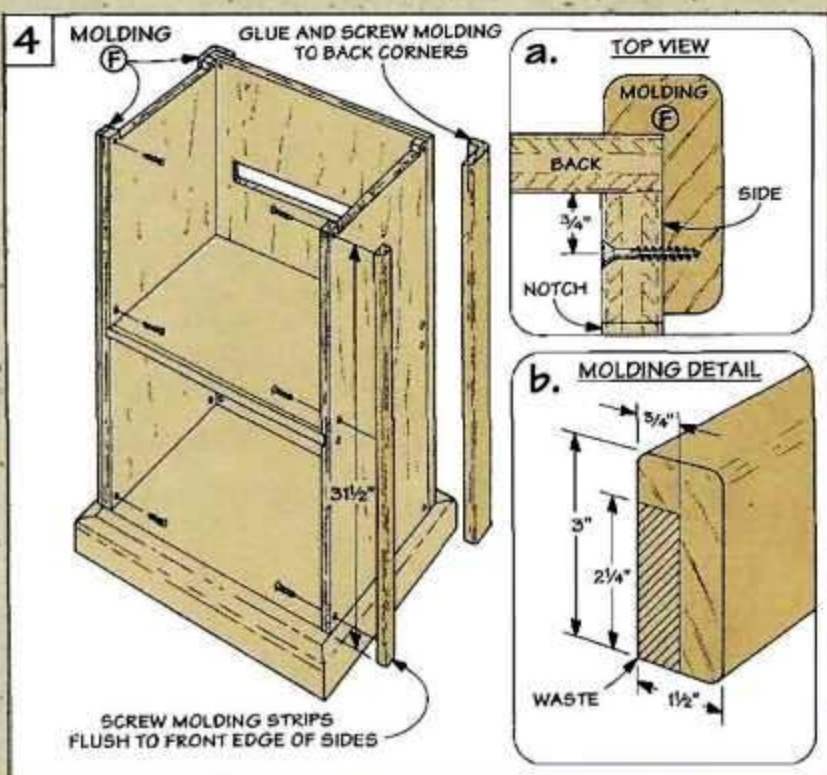

## DUST BOX

To catch sawdust and chips that fall through the router bit hole in the table top, I added a dust box that slides into the shelf in the cabinet, refer to Exploded View.

To build the box, cut a *front and back (J)* and two *sides (K)* from ¾"-thick plywood; see Fig. 7. To join the front and back to the sides, cut rabbets on the ends of the front and back, see Fig. 7a.

Next, to hold the bottom in place, cut a groove near the bottom of each piece, see Fig. 7b. Finally, cut a *bottom (L)* to fit, then glue and nail the box together.

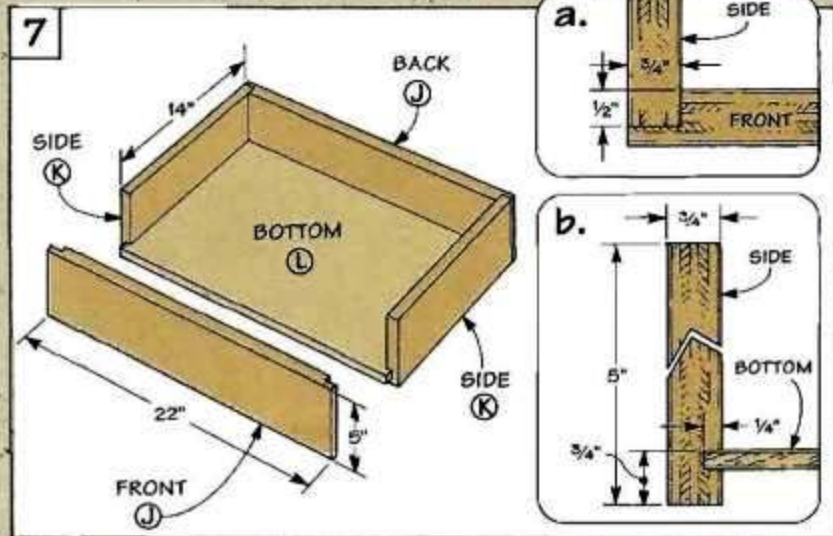

**DOORS**

With the dust box complete, the next step is to make the doors. I cut them from  $\frac{3}{4}$ "-thick plywood and covered the inside edges with edging strips, and the outside edges with the door molding strips set aside earlier.

To determine the width of the doors, first measure across the front of the cabinet from *outside* edge-to-edge, and divide this in half. Then subtract  $\frac{1}{2}$ " for the edging strip and  $\frac{1}{16}$ " for the center gap ( $11\frac{3}{16}$ ", in my case).

To determine the door length, measure from the top of the base (H) to the top of the sides and subtract  $\frac{1}{8}$ " for clearance ( $31\frac{3}{8}$ "). Now cut two doors (M) to size, see Fig. 8.

**ADD TRIM.** Then cut two  $\frac{1}{2}$ "-thick edgings (N) and glue them to the inside edges of each door. Also glue and screw the door moldings (set aside earlier) to the outside edges, see Fig. 8b.

**ASTRAGAL.** To prevent dust from escaping and to minimize

noise, I added an *astragal* (O) to the back of one door, see Fig. 9.

**HARDWARE.** Before mounting the doors, attach the handles, see Fig. 10. Then mount the doors with two piano hinges cut to the same length as the doors. Screw one hinge flap to a door and the other to the cabinet side, see Fig. 11. For clearance, insert a temporary spacer under each door before screwing them to the side.

Finally, screw magnetic catches and strike plates to the doors.

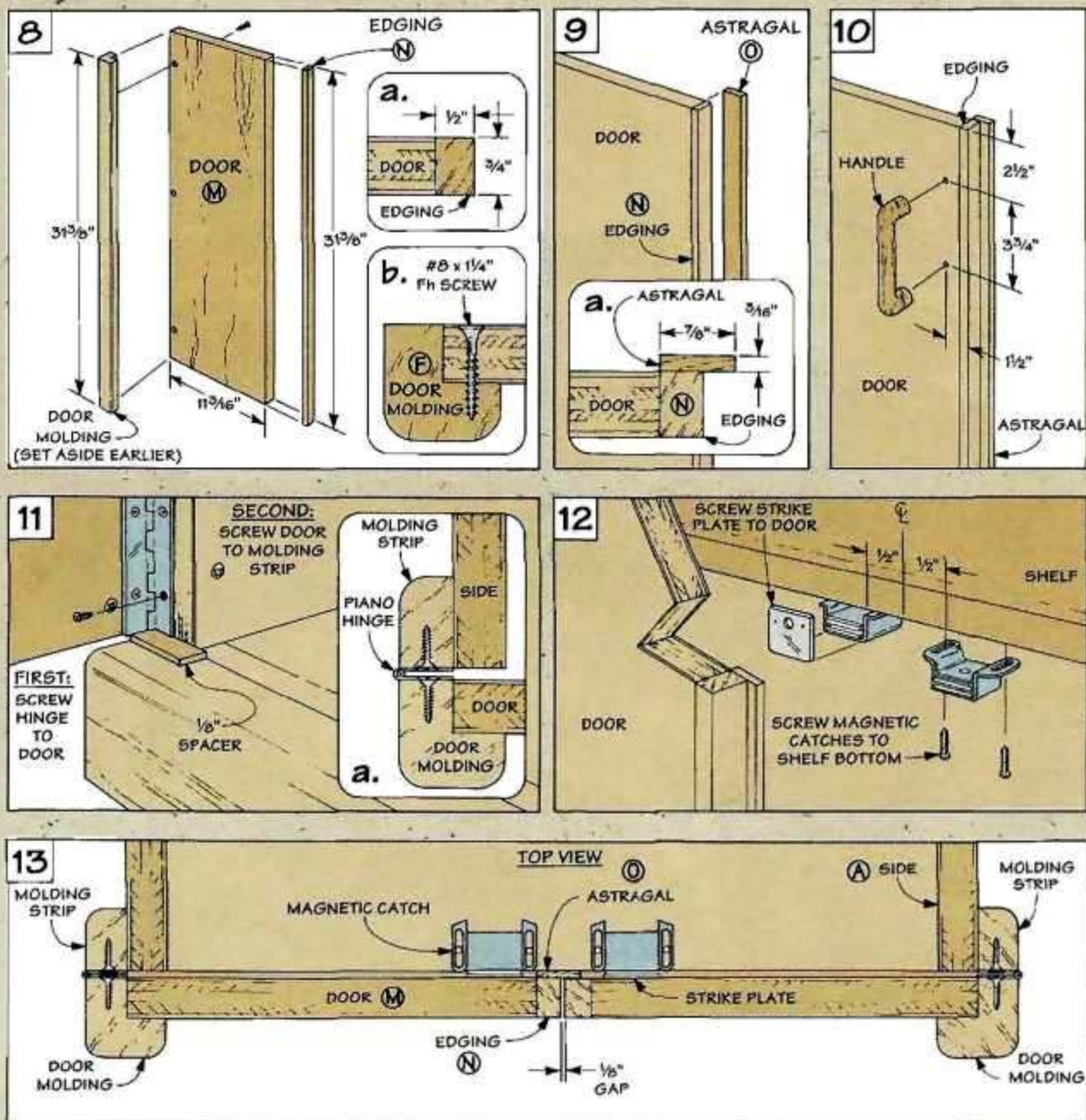

## BIT HOLDER

After the doors are mounted, I added router bit holders inside each door. These are simple holders, but designed so they won't get clogged with sawdust.

The holes are drilled all the way through the holder so sawdust falls through. To keep the bits in place, the holders are cut at an angle so the bit stops against the door, see Fig. 15a.

**CUT BLANK.** To make each bit holder (P), start by cutting a 10"-long blank from  $\frac{3}{4}$ "-thick hardwood, see Fig. 14.

**DRILL HOLES.** Next, drill a series of holes the same size as the shanks of your router bits. Note: If your router bits don't slide easily in and out of the holes, enlarge the holes slightly with a dowel wrapped with sandpaper.

It's also easier to drill and countersink the two screw holes used to mount the holders before cutting the holder at an angle, see Fig. 14.

**RIP BLANK.** After the holes are drilled, the next step is to bevel rip the holder along its length at

45°. To do this, position the rip fence on your table saw to cut the holder  $1\frac{5}{8}$ " wide, see Fig. 14a.

Once the holders are ripped, screw them to the doors, positioning each holder  $3\frac{3}{4}$ " apart and  $\frac{1}{2}$ " in from the inside edge, see Fig. 15.

**CABINET TOP.** Aside from the wiring (see the section below) and mounting the router table top, the cabinet is complete. To mount the top, I used the same mounting brackets shown on page 18 of *ShopNotes* No. 1.

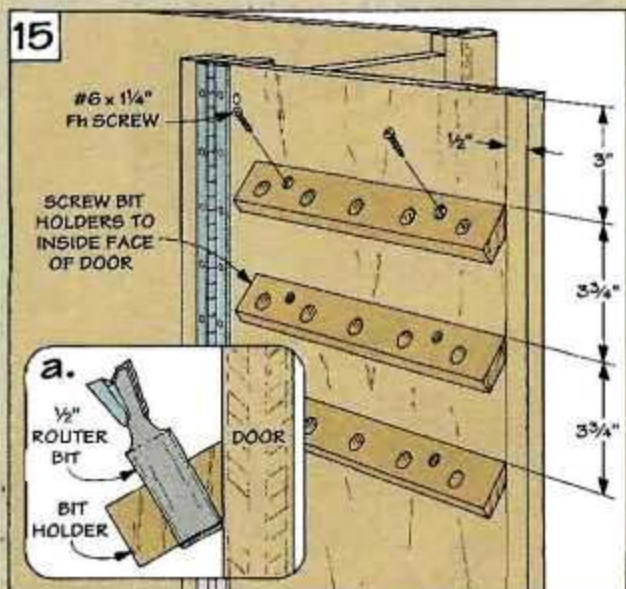
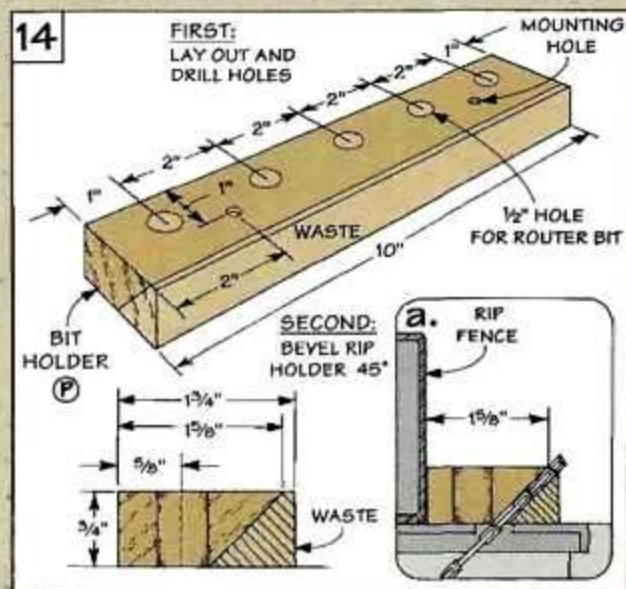

## WIRING

To make it easy to turn the router on and off, I added a switch. It controls power to an outlet in the cabinet, see Fig. 16.

**ADDING A SWITCH.** To add a switch, first drill a hole in the cabinet side for the wiring to pass through, see Fig. 16. Then, screw the electrical boxes to the cabinet. Next, wire the switch to the outlet. Finally, screw the switch and outlet into the boxes and add an outlet and switch cover.

**OUTLET STRIP.** If you're not comfortable with wiring, consult a licensed electrician. Or, you can install a "switched" outlet strip, see Fig. 16a.

